

OUR GLOBAL
COMPETENCE
CENTRES

 APOLLO DISPLAY
TECHNOLOGIES



 DISTEC



 DISPLAY
TECHNOLOGY



Datasheet

LG Display

L6 %a09\$%G@%; Yb")

HD-10-€Jİ ÜFË

Product Specification

SPECIFICATION FOR APPROVAL

- () Preliminary Specification
 (●) Final Specification

Title	17" SXGA TFT LCD
-------	------------------







Customer	
MODEL	

SUPPLIER	LG Display Co., Ltd.
*MODEL	LB170E01
Suffix	SL01

*When you obtain standard approval,
please use the above model name without suffix

APPROVED BY	SIGNATURE DATE
/	
/	
/	

Please return 1 copy for your confirmation with your signature and comments.

APPROVED BY	SIGNATURE DATE
Y.T. Woo / G.Manager	
REVIEWED BY	
C.K. Lee / Manager [C]	
B.C. Lee / Manager [M]	
S.H. Cho / Manager [O]	
J.K. Lee / Manager [P]	
PREPARED BY	
J.H. Yang / Engineer	

Product Engineering Dept.
LG Display Co., Ltd

Product Specification
Contents

No	ITEM	Page
	COVER	1
	CONTENTS	2
	RECORD OF REVISIONS	3
1	GENERAL DESCRIPTION	4
2	ABSOLUTE MAXIMUM RATINGS	5
3	ELECTRICAL SPECIFICATIONS	6
3-1	ELECTRICAL CHARACTREISTICS	6
3-2	INTERFACE CONNECTIONS	8
3-3	SIGNAL TIMING SPECIFICATIONS	13
3-4	SIGNAL TIMING WAVEFORMS	14
3-5	COLOR INPUT DATA REFERNECE	15
3-6	POWER SEQUENCE	16
3-7	V _{LCD} Power Dip Condition	17
4	OPTICAL SFECIFICATIONS	18
5	MECHANICAL CHARACTERISTICS	24
6	RELIABLITY	27
7	INTERNATIONAL STANDARDS	28
7-1	SAFETY	28
7-2	EMC	28
7-3	ENVIRONMENT	28
8	PACKING	29
8-1	DESIGNATION OF LOT MARK	30
8-2	PACKING FORM	29
9	PRECAUTIONS	30

Product Specification

1. General Description

LB170E01 is a Color Active Matrix Liquid Crystal Display with an integral Light Emitting Diode (White LED) backlight system. The matrix employs a-Si Thin Film Transistor as the active element. It is a transmissive type display operating in the normally black mode. It has a 17.0 inch diagonally measured active display area with SXGA resolution (1024 vertical by 1280 horizontal pixel array) Each pixel is divided into Red, Green and Blue sub-pixels or dots which are arranged in vertical stripes. Gray scale or the brightness of the sub-pixel color is determined with a 8-bit gray scale signal for each dot, thus, presenting a palette of more than 16,7M colors

It has been designed to apply the 8Bit 2 port LVDS interface.

It is intended to support displays where high brightness, super wide viewing angle, high color saturation, and high color are important.

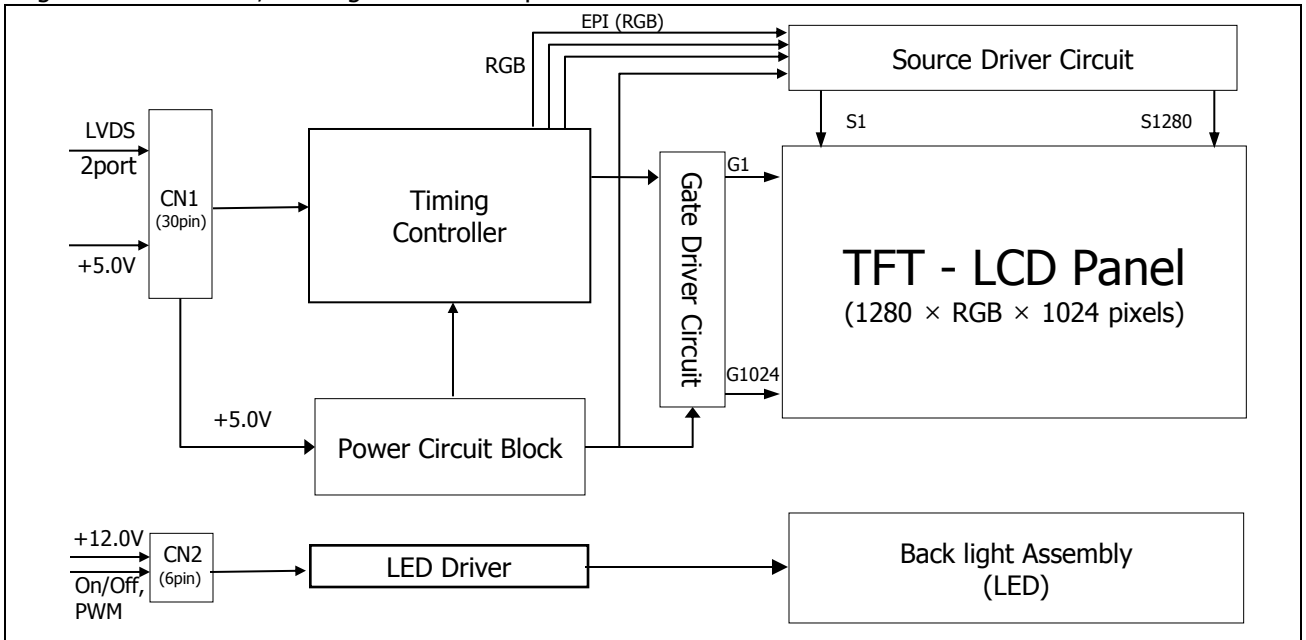

[Figure 1] Block diagram

General Features

Active Screen Size	17.0 inch (432.75mm) diagonal
Outline Dimension	368.0(H) x 306.0(V) x 14.3(D) mm(Typ.)
Pixel Pitch	0.264 mm x 0.264mm
Pixel Format	1280 horiz. by 1024 vert. Pixels. RGB stripe arrangement
Color Depth	16,7M colors
Luminance, White	400 cd/m ² (Center 1 Point, Typ.)
Viewing Angle(CR>10)	View Angle Free (R/L 178(Typ.), U/D 178(Typ.))
Power Consumption	Total 15.2 Watt (Typ.) (2.6 Watt @VLCD, 12.6 Watt @VBL)
Weight	1260 g (typ.),1310g(max.)
Display Operating Mode	Transmissive mode, normally black
Panel type	Forward type
Surface Treatment	Hard coating(3H), Anti-Glare treatment of the front polarizer

Product Specification

2. Absolute Maximum Ratings

The following are maximum values which, if exceeded, may cause faulty operation or damage to the unit.

Table 1. ABSOLUTE MAXIMUM RATINGS

Parameter	Symbol	Values		Units	Notes
		Min	Max		
Power Input Voltage	V _{LCD}	-0.3	6.0	V _{dc}	at 25 ± 2°C
Operating Temperature	T _{OP}	-10	70	°C	1, 2, 3
Storage Temperature	T _{ST}	-20	80	°C	
Operating Ambient Humidity	H _{OP}	10	90	%RH	
Storage Humidity	H _{ST}	10	90	%RH	

- Note :
1. Temperature and relative humidity range are shown in the figure below.
Wet bulb temperature should be 39 °C Max, and no condensation of water.
 2. Maximum Storage Humidity is up to 40 °C, 70% RH only for 4 corner light leakage Mura.
 3. Storage condition is guaranteed under packing condition

FIG.2 Temperature and relative humidity

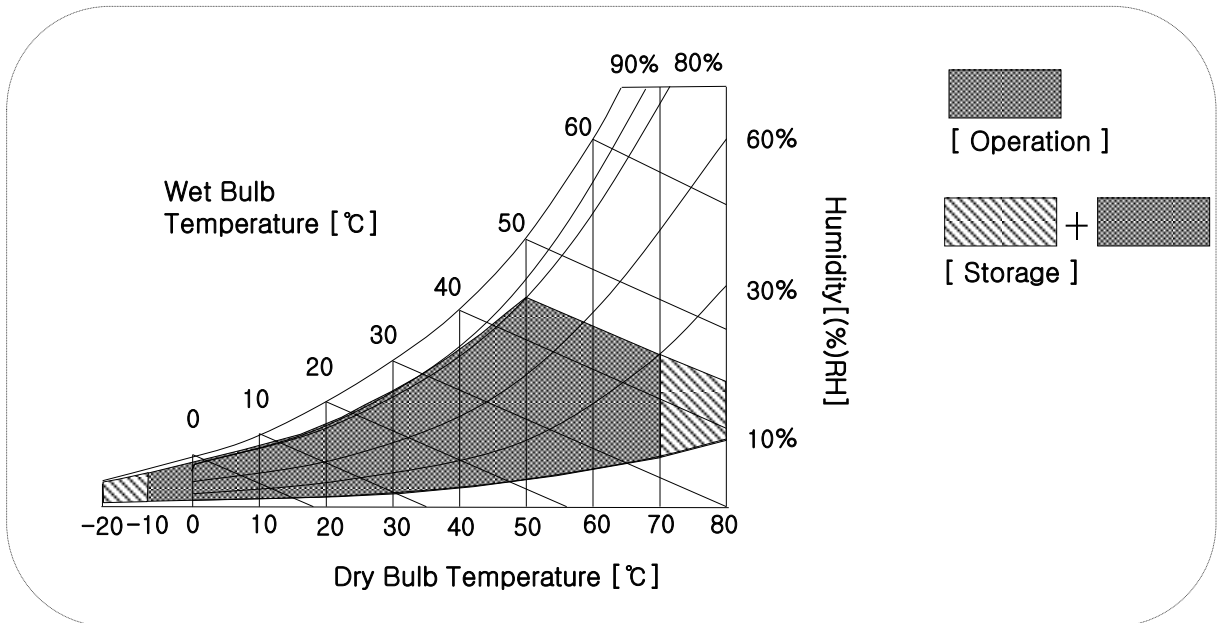

Product Specification
3. Electrical Specifications
3-1. Electrical Characteristics

It requires two power inputs. One is employed to power the LCD electronics and to drive the TFT array and liquid crystal. The other input power for the LED/Backlight, is typically generated by a LED Driver. The LED Driver is an internal unit to the LCDs.

Table 2-1. LCD Module ELECTRICAL CHARACTERISTICS

Parameter	Symbol	Values			Unit	Notes
		Min	Typ	Max		
MODULE :						
Power Supply Input Voltage	V _{LCD}	4.5	5.0	5.5	Vdc	
Power Supply Input Current	I _{LCD}	-	520	676	mA	1
		-	720	936	mA	
Power Consumption	P _C TYP	-	2.60	3.38	Watt	
	P _C MAX	-	3.60	4.68	Watt	
Differential Impedance	Z _m	90	100	110	Ohm	
Rush current	I _{RUSH}	-	-	3.0	A	2
BACKLIGHT(With LED Driver):						
LED Power Supply Voltage	V _{BL}	11.5	12	12.5	V	
LED Power Supply Current	I _{BL}	-	1050	1155	mA	
LED Power Consumption	P _{BL}	-	12.6	13.86	Watt	
PWM Duty Ratio		10		100	%	
PWM Dimming Frequency	F _{PWM}	9	10	11	KHz	
PWM Duty High Voltage	V _H	3.0	3.3	3.6	Vdc	
PWM Duty Low Voltage	V _L	0.0		0.3	Vdc	
Backlight Enable Voltage	V _{ON}	-	3.3	-	Vdc	
Backlight Disable Voltage	V _{OFF}	-	0	-	Vdc	
Life Time	LED_LT	50,000	-	-	Hrs	7

Product Specification
Note :

1. The specified current and power consumption are under the $V_{LCD}=5.0V$, $25\text{ }^{\circ}C$, $f_V=60Hz$ condition and the pattern should be changed according to the typical or maximum power condition.
The Max current can be measured only with the maximum power pattern
2. Maximum Condition of Inrush current :
The duration of rush current is about 5ms and rising time of power Input is $500\mu s \pm 20\%$.(min.).
3. VLCD level must be measured between two points on PCB of LCM (VLCD (test point) ~ LCM Ground)
(Test condition : maximum power pattern, $25^{\circ}C$, $f_V=60Hz$)
4. The current and power consumption with LED Driver are under the $V_{BL} = 12.0V$, $25^{\circ}C$, Dimming of Max luminance and White pattern with the normal frame frequency operated(60Hz).
5. The operation of LED Driver below minimum dimming ratio may cause flickering or reliability issue.
6. This Spec. is not effective at 100% dimming ratio as an exception because it has DC level equivalent to 0Hz. In spite of acceptable range as defined, the PWM Frequency should be fixed and stable for more consistent brightness control at any specific level desired.
7. The LED life time is defined as the time when the LED PKG brightness reach to the 50% of initial value under the conditions at $T_a = 25 \pm 2^{\circ}C$ and typical LED string current.

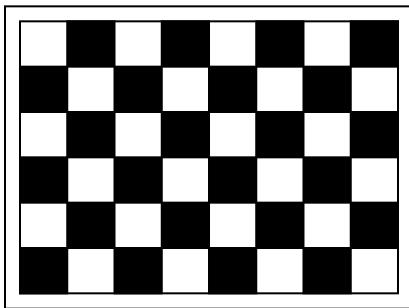
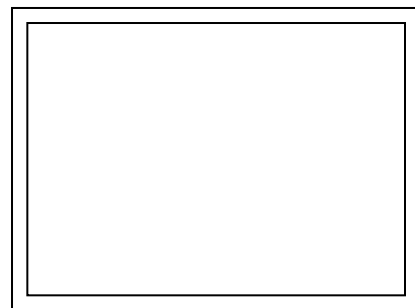
Typical power Pattern

Maximum power Pattern
FIG.3 Mosaic pattern & White Pattern for power consumption measurement

Product Specification

3-2. Interface Connections

3-2-1. LCD Module

- LCD Connector(CN1). : IS100-L30B-C23 (UJU)
- Mating Connector : FI-X30C2L (Manufactured by JAE) or Equivalent

Table 3. MODULE CONNECTOR(CN1) PIN CONFIGURATION

No	Symbol	Description	No	Symbol	Symbol
1	RX00-	Minus signal of odd channel 0 (LVDS)	16	RXE1+	Plus signal of even channel 1 (LVDS)
2	RX00+	Plus signal of odd channel 0 (LVDS)	17	GND	Ground
3	RX01-	Minus signal of odd channel 1 (LVDS)	18	RXE2-	Minus signal of even channel 2 (LVDS)
4	RX01+	Plus signal of odd channel 1 (LVDS)	19	RXE2+	Plus signal of even channel 2 (LVDS)
5	RX02-	Minus signal of odd channel 2 (LVDS)	20	RXEC-	Minus signal of even clock channel (LVDS)
6	RX02+	Plus signal of odd channel 2 (LVDS)	21	RXEC+	Plus signal of even clock channel (LVDS)
7	GND	Ground	22	RXE3-	Minus signal of even channel 3 (LVDS)
8	RXOC-	Minus signal of odd clock channel (LVDS)	23	RXE3+	Plus signal of even channel 3 (LVDS)
9	RXOC+	Plus signal of odd clock channel (LVDS)	24	GND	Ground
10	RX03-	Minus signal of odd channel 3 (LVDS)	25	NC	No Connection.(I2C Serial interface for LCM)
11	RX03+	Plus signal of odd channel 3 (LVDS)	26	NC	No Connection.(I2C Serial interface for LCM)
12	RXE0-	Minus signal of even channel 0 (LVDS)	27	NC	No Connection.
13	RXE0+	Plus signal of even channel 0 (LVDS)	28	V _{LCD}	Power Supply +5.0V
14	GND	Ground	29	V _{LCD}	Power Supply +5.0V
15	RXE1-	Minus signal of even channel 1 (LVDS)	30	V _{LCD}	Power Supply +5.0V

- Note:
1. All GND(ground) pins should be connected together and to Vss which should also be connected to the LCD's metal frame.
 2. All V_{LCD} (power input) pins should be connected together.
 3. Input Level of LVDS signal is based on the IEA 664 Standard.

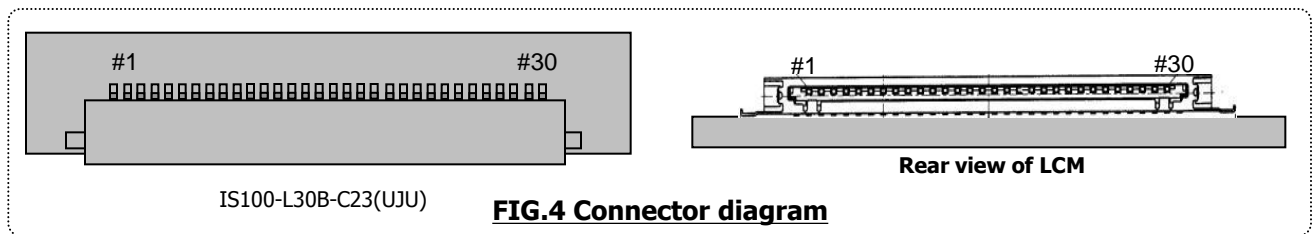

Product Specification

3-2-2. BACKLIGHT

- BACKLIGHT Connector(CN2). : **10031HR-H06 (YENHO)**

Table 4. BACKLIGHT CONNECTOR(CN2) PIN CONFIGURATION

No	Symbol	Description
1	V _{BL}	Backlight Power Supply(12.0 Typ.)
2	V _{BL}	Backlight Power Supply(12.0 Typ.)
3	V _{BL}	Backlight Power Supply(12.0 Typ.)
4	GND	Ground
5	On/Off	Backlight On/Off, High(3.3V Typ.): On, Low(Ground): Off
6	PWM	PWM Dimming Signal

Note: 1. All GND(ground) pins should be connected together and the LCD's metal frame.
 2. All V_{BL} (power input) pins should be connected together.

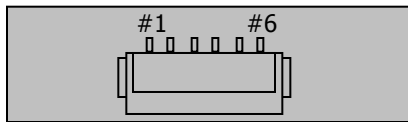

10031HR-H06(YEONHO)

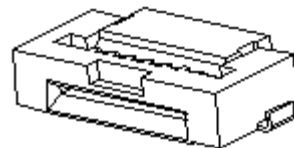

FIG.5 Connector diagram

Product Specification

Table 4. REQUIRED SIGNAL ASSIGNMENT FOR Flat Link (THINE:THC63LVD823) Transmitter

Pin#	Pin Name	Description	Pin#	Pin Name	Description
1	B24	The 2nd Pixel Data Input	51	R10	The 1st Pixel Data Input
2	B25	The 2nd Pixel Data Input	52	R11	The 1st Pixel Data Input
3	VCC	Power Supply for TTL input	53	R12	The 1st Pixel Data Input
4	GND	Ground for TTL input	54	R13	The 1st Pixel Data Input
5	B26	The 2nd Pixel Data Input	55	VCC	Power Supply for TTL input
6	B27	The 2nd Pixel Data Input	56	GND	Ground for TTL input
7	HSYNC	Hsync Input	57	R14	The 1st Pixel Data Input
8	VSYNC	Vsync Input	58	R15	The 1st Pixel Data Input
9	DE	Data Enable Input	59	R16	The 1st Pixel Data Input
10	CLKIN	Clock Input	60	R17	The 1st Pixel Data Input
11	R/F	Input Clock Triggering Edge Select	61	G10	The 1st Pixel Data Input
12	RS	LVDS swig range select	62	G11	The 1st Pixel Data Input
13	TEST1	Test pin	63	G12	The 1st Pixel Data Input
14	TEST2	Test pin	64	G13	The 1st Pixel Data Input
15	MODE1	Pixel Data Mode	65	G14	The 1st Pixel Data Input
16	MODE0	Pixel Data Mode	66	G15	The 1st Pixel Data Input
17	OE	Output enable	67	G16	The 1st Pixel Data Input
18	6/8	6bit/8bit color select	68	G17	The 1st Pixel Data Input
19	/PDWN	Power down	69	B10	The 1st Pixel Data Input
20	TEST3	Test pin	70	B11	The 1st Pixel Data Input
21	TEST4	Test pin	71	VCC	Power Supply for TTL input
22	TEST5	Test pin	72	GND	Ground for TTL input
23	PLL GND	Ground for PLL circuitry	73	B12	The 1st Pixel Data Input
24	PLL VCC	Power Supply for PLL circuitry	74	B13	The 1st Pixel Data Input
25	PLL GND	Ground for PLL circuitry	75	B14	The 1st Pixel Data Input
26	LVDS GND	Ground for LVDS output	76	B15	The 1st Pixel Data Input
27	TD2+	The 2nd Link. The 2nd pixel output data	77	B16	The 1st Pixel Data Input
28	TD2-	The 2nd Link. The 2nd pixel output data	78	B17	The 1st Pixel Data Input
29	TCLK2+	LVDS Clock Out for 2nd Link	79	B20	The 2nd Pixel Data Input
30	TCLK2-	LVDS Clock Out for 2nd Link	80	B21	The 2nd Pixel Data Input
31	TC2	The 2nd Link. The 2nd pixel output data	81	B22	The 2nd Pixel Data Input
32	TC2+	The 2nd Link. The 2nd pixel output data	82	B23	The 2nd Pixel Data Input
33	LVDS VCC	Power Supply for LVDS Output	83	B24	The 2nd Pixel Data Input
34	TB2+	The 2nd Link. The 2nd pixel output data	84	B25	The 2nd Pixel Data Input
35	TB2-	The 2nd Link. The 2nd pixel output data	85	B26	The 2nd Pixel Data Input
36	TA2+	The 2nd Link. The 2nd pixel output data	86	B27	The 2nd Pixel Data Input
37	TA2-	The 2nd Link. The 2nd pixel output data	87	VCC	Power Supply for TTL input
38	LVDS GND	Ground for LVDS output	88	GND	Ground for TTL input
39	TD1+	The 1st Link. The 1st Pixel output data	89	G20	The 2nd Pixel Data Input
40	TD1-	The 1st Link. The 1st Pixel output data	90	G21	The 2nd Pixel Data Input
41	TCLK1+	LVDS Clock Out for 1st Link	91	G22	The 2nd Pixel Data Input
42	TCLK1-	LVDS Clock Out for 1st Link	92	G23	The 2nd Pixel Data Input
43	TC1+	The 1st Link. The 1st Pixel output data	93	G24	The 2nd Pixel Data Input
44	TC1-	The 1st Link. The 1st Pixel output data	94	G25	The 2nd Pixel Data Input
45	LVDS VCC	Power Supply for LVDS Output	95	G26	The 2nd Pixel Data Input
46	TB1+	The 1st Link. The 1st Pixel output data	96	G27	The 2nd Pixel Data Input
47	TB1-	The 1st Link. The 1st Pixel output data	97	B20	The 2nd Pixel Data Input
48	TA1+	The 1st Link. The 1st Pixel output data	98	B21	The 2nd Pixel Data Input
49	TA1-	The 1st Link. The 1st Pixel output data	99	B22	The 2nd Pixel Data Input
50	LVDS GND	Ground for LVDS output	100	B23	The 2nd Pixel Data Input

Note : Refer to LVDS Transmitter Data Sheet for detail descriptions.

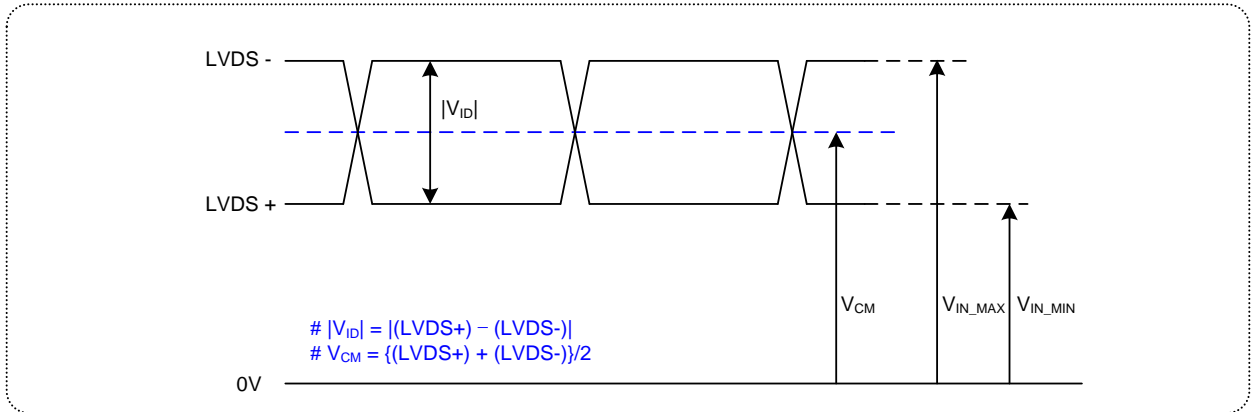
Product Specification
LVDS Input characteristics
1. DC Specification

Description	Symbol	Min	Max	Unit	Notes
LVDS Differential Voltage	$ V_{ID} $	200	600	mV	-
LVDS Common mode Voltage	V_{CM}	1.0	1.5	V	-
LVDS Input Voltage Range	V_{IN}	0.7	1.8	V	-
Change in common mode Voltage	ΔV_{CM}	-	250	mV	-

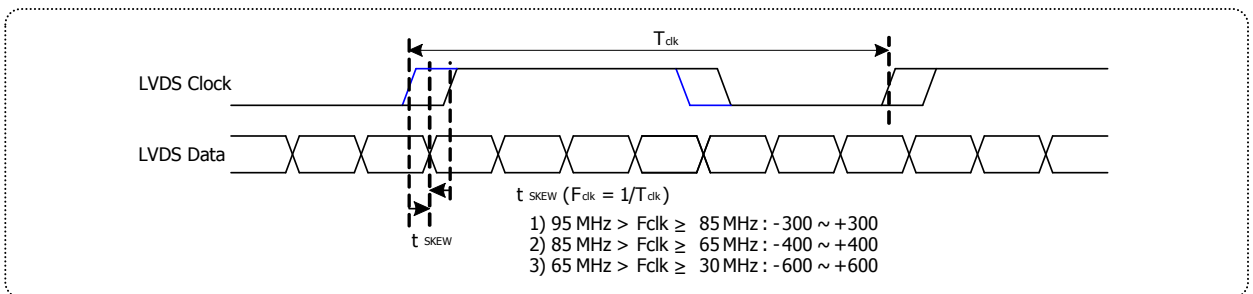
2. AC Specification

Description	Symbol	Min	Max	Unit	Notes
LVDS Clock to Data Skew Margin	t_{SKEW}	- 300	+ 300	ps	95MHz > Fclk ≥ 85MHz
	t_{SKEW}	- 400	+ 400	ps	85MHz > Fclk ≥ 65MHz
	t_{SKEW}	- 600	+ 600	ps	65MHz > Fclk ≥ 30MHz
LVDS Clock to Clock Skew Margin (Even to Odd)	t_{SKEW_EO}	- 1/7	+ 1/7	T_{clk}	-

Product Specification

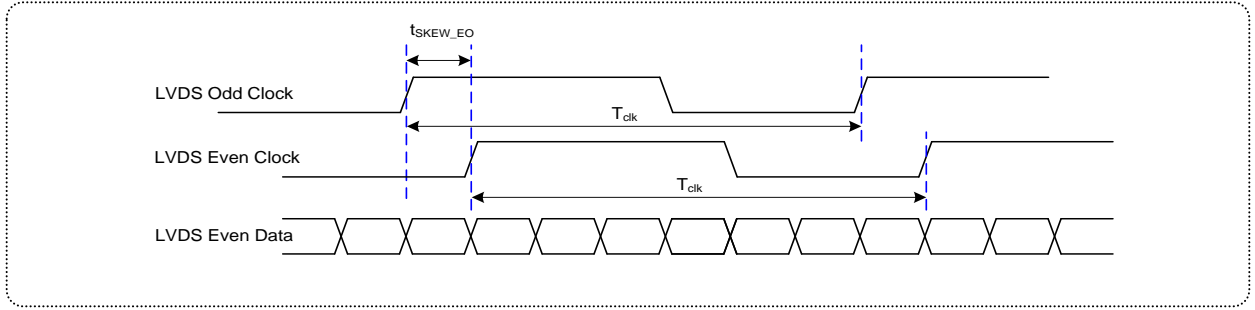

< Clock skew margin between channel >

3. Data Format

1) LVDS 2 Port

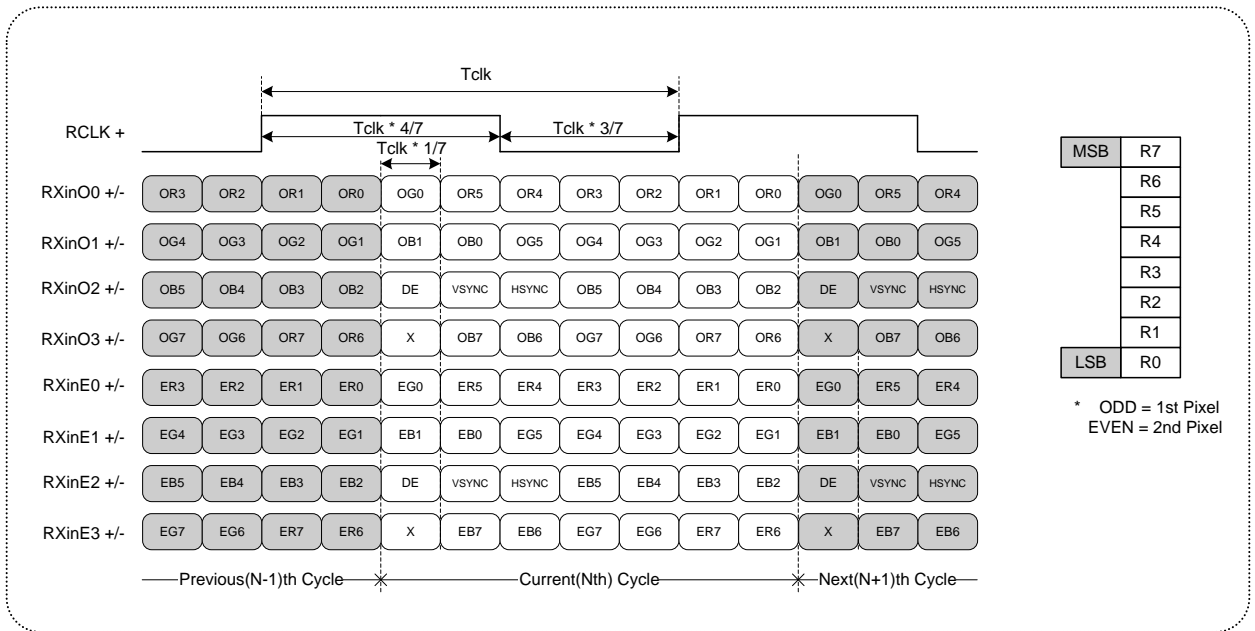

< LVDS Data Format >

Product Specification
3-3. Signal Timing Specifications

This is signal timing requirement from the signal transmitter. All of the interface signal timing should satisfy the following specifications for its proper operation.

Table 6. TIMING TABLE

ITEM	Symbol		Min	Typ	Max	Unit	Note
DCLK	Period	tCLK	14.7	18.5	23.6	ns	
	Frequency	-	42.3	54.0	68.4	MHz	
Horizontal	total	tHP	688	844	960	tCLK	1,2,3,4
	Frequency	fH	49.4	64.0	81.3	KHz	
	Blanking		48	204	300	tCLK	
	valid	tWH	640	640	640	tCLK	
Vertical	total	tVP	1040	1066	1320	tHP	2,4
	Frequency	fV	47	60	76	Hz	
	Blanking		16	42	296	tHP	
	valid	tWV	1024	1024	1024	tHP	

Note:

1. The value of Hsync period, Hsync width and Hsync valid should be even number times of tCLK.
If the value is odd number times of tCLK, it can make asynchronous signal timing and cause abnormal display.
2. The performance of the electro-optical characteristics may be influenced by variance of the vertical refresh rates.
3. The value of Hsync Period, Hsync Width, and Horizontal Back Porch should be divided by 4 without a remainder.
4. The polarity of Hsync, Vsync is not restricted.

3-4. Signal Timing Waveforms

1. DCLK, DE, DATA waveforms

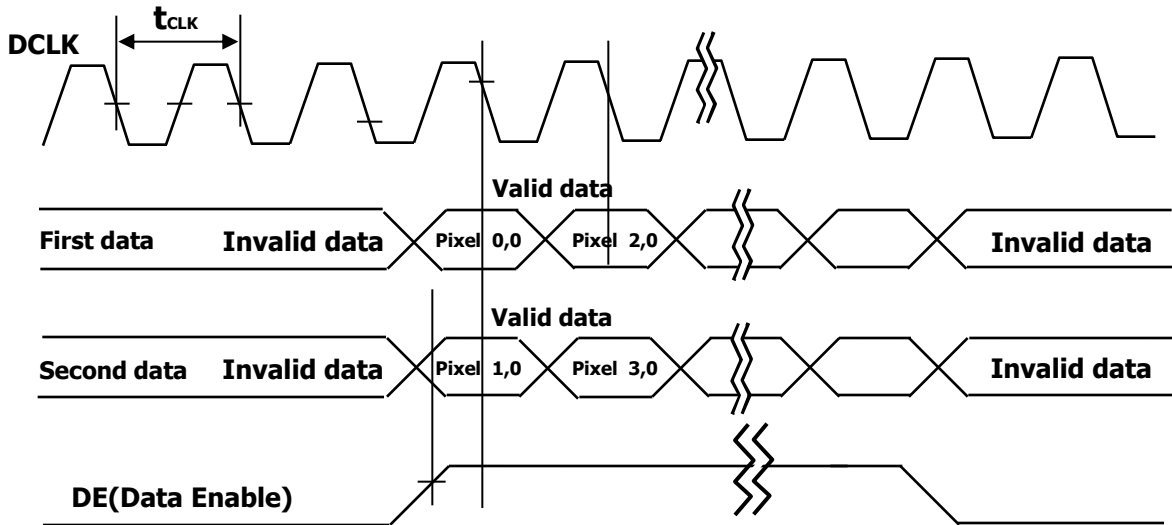

2. Horizontal waveform

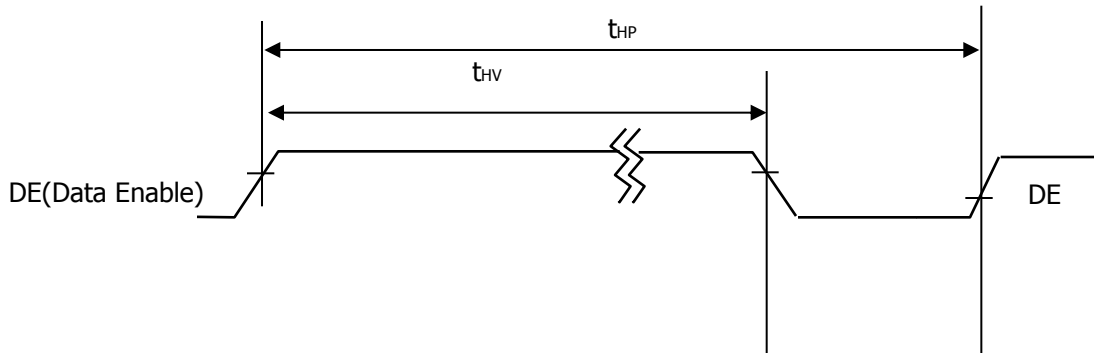

3. Vertical waveform

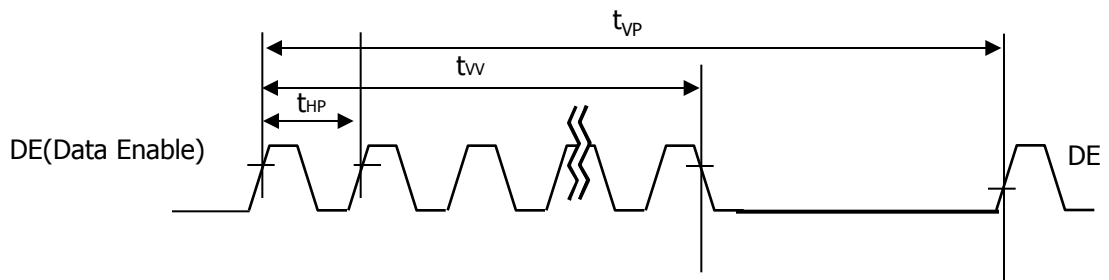

Product Specification

3-5. Color Input Data Reference

The Brightness of each primary color(red,green,blue) is based on the 8-bit gray scale data input for the color; the higher the binary input, the brighter the color. The table below provides a reference for color versus data input.

Table 7. COLOR DATA REFERENCE

Color		Input Color Data																							
		RED								GREEN								BLUE							
		MSB				LSB				MSB				LSB				MSB				LSB			
		R7	R6	R5	R4	R3	R2	R1	R0	G7	G6	G5	G4	G3	G2	G1	G0	B7	B6	B5	B4	B3	B2	B1	B0
Basic Color	Black	0	0	0	0	0	0	0	0	0	0	0	0	0	0	0	0	0	0	0	0	0	0	0	0
	Red (255)	1	1	1	1	1	1	1	1	0	0	0	0	0	0	0	0	0	0	0	0	0	0	0	0
	Green (255)	0	0	0	0	0	0	0	0	1	1	1	1	1	1	1	1	0	0	0	0	0	0	0	0
	Blue (255)	0	0	0	0	0	0	0	0	0	0	0	0	0	0	0	0	1	1	1	1	1	1	1	1
	Cyan	0	0	0	0	0	0	0	0	1	1	1	1	1	1	1	1	1	1	1	1	1	1	1	1
	Magenta	1	1	1	1	1	1	1	1	0	0	0	0	0	0	0	0	1	1	1	1	1	1	1	1
	Yellow	1	1	1	1	1	1	1	1	1	1	1	1	1	1	1	1	0	0	0	0	0	0	0	0
	White	1	1	1	1	1	1	1	1	1	1	1	1	1	1	1	1	1	1	1	1	1	1	1	1
RED	RED (000) Dark	0	0	0	0	0	0	0	0	0	0	0	0	0	0	0	0	0	0	0	0	0	0	0	0
	RED (001)	0	0	0	0	0	0	0	1	0	0	0	0	0	0	0	0	0	0	0	0	0	0	0	0
							
	RED (254)	1	1	1	1	1	1	1	0	0	0	0	0	0	0	0	0	0	0	0	0	0	0	0	0
	RED (255)	1	1	1	1	1	1	1	1	0	0	0	0	0	0	0	0	0	0	0	0	0	0	0	0
GREEN	GREEN (000) Dark	0	0	0	0	0	0	0	0	0	0	0	0	0	0	0	0	0	0	0	0	0	0	0	0
	GREEN (001)	0	0	0	0	0	0	0	0	0	0	0	0	0	0	0	1	0	0	0	0	0	0	0	0
							
	GREEN (254)	0	0	0	0	0	0	0	0	1	1	1	1	1	1	1	0	0	0	0	0	0	0	0	0
	GREEN (255)	0	0	0	0	0	0	0	0	1	1	1	1	1	1	1	1	0	0	0	0	0	0	0	0
BLUE	BLUE (000) Dark	0	0	0	0	0	0	0	0	0	0	0	0	0	0	0	0	0	0	0	0	0	0	0	0
	BLUE (001)	0	0	0	0	0	0	0	0	0	0	0	0	0	0	0	0	0	0	0	0	0	0	0	1
							
	BLUE (254)	0	0	0	0	0	0	0	0	0	0	0	0	0	0	0	0	1	1	1	1	1	1	1	0
	BLUE (255)	0	0	0	0	0	0	0	0	0	0	0	0	0	0	0	0	1	1	1	1	1	1	1	1

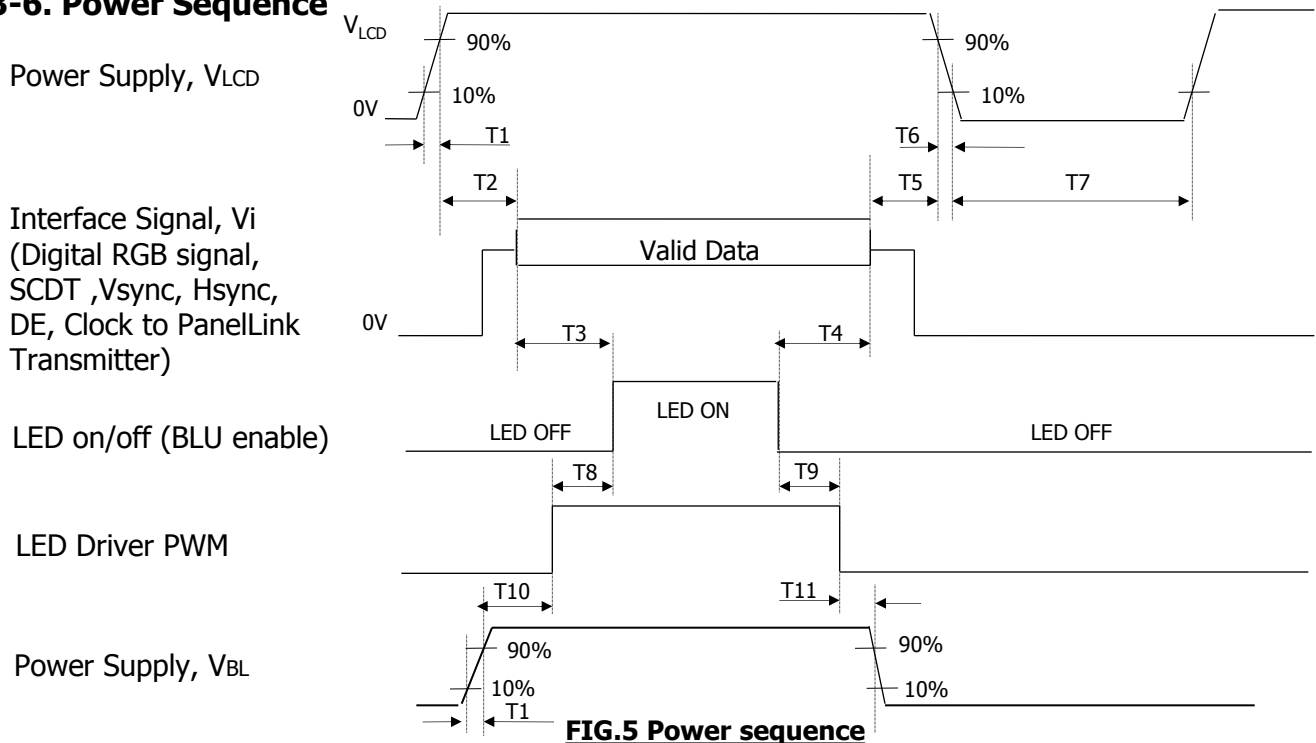
Product Specification
3-6. Power Sequence

FIG.5 Power sequence
Table 8. POWER SEQUENCE

Parameter	Values			Units
	Min	Typ	Max	
T1	0.5	-	10	ms
T2	0.01	-	50	ms
T3	500	-	-	ms
T4	200	-	-	ms
T5	0.01	-	50	ms
T7	1000	-	-	ms
T8	50	-	400	ms
T9	50	-	150	ms
T10	10	-	-	ms
T11	10	-	-	ms

Notes :

- Power sequence should be kept all the time including below cases for normal operation.
 - AC/DC Power On/Off
 - Mode change (Resolution, frequency, timing, sleep mode, Color depth change, etc.)
 The violation of power sequence can cause a significant trouble in display and reliability.
- Please avoid floating state of interface signal during signal invalid period.
- When the interface signal is invalid, be sure to pull down the V_{LCD} (0V).
- Please turn off the power supply for LED when the level of V_{LCD} changes to prevent noise issue.

3-7. V_{LCD} Power Dip Condition

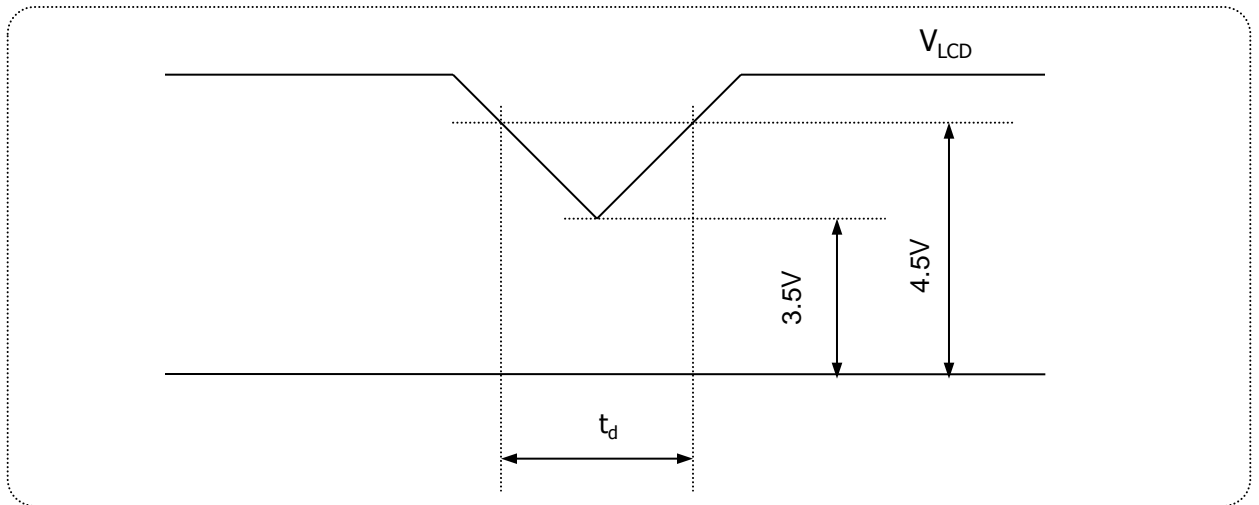

FIG.6 Power dip condition

For proper operation, stable power supply of V_{LCD} is necessary and power dip is allowed only in below condition. Except this condition, power on/off should follow power sequence specification in page 16 exactly.

1) Dip condition

$$3.5V \leq V_{LCD} < 4.5V, t_d \leq 20ms$$

Product Specification
4. Optical Specifications

Optical characteristics are determined after the unit has been 'ON' for approximately 30 minutes in a dark environment at $25 \pm 2^\circ\text{C}$. The values specified are at an approximate distance 50cm from the LCD surface at a viewing angle of Φ and θ equal to 0° and aperture 1 degree.

FIG. 4 presents additional information concerning the measurement equipment and method.

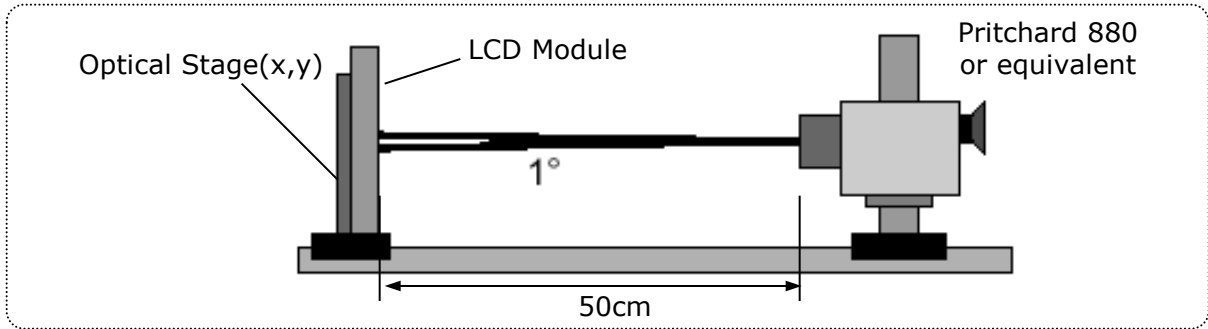
FIG. 7 Optical Characteristic Measurement Equipment and Method
Table 9. OPTICAL CHARACTERISTICS
 $(T_a=25^\circ\text{C}, V_{\text{LCD}}=5\text{V}, f_v=60\text{Hz Dclk}=108\text{MHz})$

Parameter	Symbol	Values			Units	Notes	
		Min	Typ	Max			
Contrast Ratio	CR	600	1000	-		1	
Surface Luminance, white	L_{WH}	320	400	-	cd/m ²	2	
Luminance Variation	δ_{WHITE}	-	-	1.33		3	
Response Time	Gray To Gray	$T_{\text{GTG_AVR}}$	-	14	25	ms	4
Color Coordinates [CIE1931] <i>(By PR650)</i>	RED	Rx		0.635			
		Ry		0.349			
	GREEN	Gx		0.314			
		Gy	Typ	0.632	Typ		
	BLUE	Bx	-0.03	0.153	+0.03		
		By		0.064			
	WHITE	Wx		0.310			
	Wy		0.338				
Color Shift	Horizontal	$\theta_{\text{CST_H}}$	-	176	-	Degree	5
	Vertical	$\theta_{\text{CST_V}}$	-	176	-		
Viewing Angle (CR>10)							
General	Horizontal	θ_{H}	170	178	-	Degree	6
	Vertical	θ_{V}	170	178	-		
GSR @ 60dgree (Gamma shift rate)	Horizontal	$\delta_{\text{Gamma_H}}$	-	-	20	%	7
	Vertical	$\delta_{\text{Gamma_V}}$	-	-	20		
Gray Scale	-	-	2.2	-	-		8

Product Specification

Notes:

- Contrast ratio (CR)** is defined mathematically as : **(By PR880)**
It is measured at center point (1)

$$\text{Contrast ratio} = \frac{\text{Surface luminance with all white pixels}}{\text{Surface luminance with all black pixels}}$$

- Surface luminance** is the luminance value at center 1 point (1) across the LCD surface 50cm from the surface with all pixels displaying white. For more information see Figure 7. **(By PR880)**
- The **variation in surface luminance** , δ_{WHITE} is defined as : **(By PR880)**

$$\delta_{\text{WHITE}} = \frac{\text{Maximum } (L_{P1}, L_{P2}, \dots, L_{P9})}{\text{Minimum } (L_{P1}, L_{P2}, \dots, L_{P9})}$$

Where L1 to L9 are the luminance with all pixels displaying white at 9 location.
For more information see FIG.8

FIG 8. Luminance measuring point

<Measuring point for luminance variation>

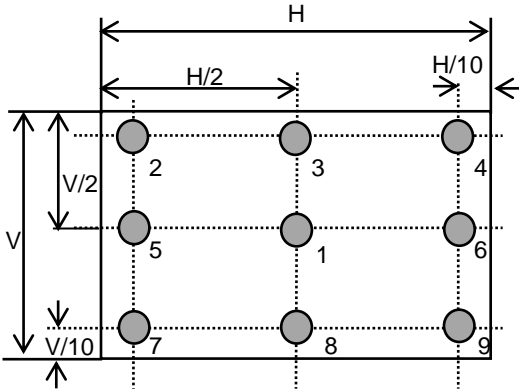

<Measuring point for surface luminance>

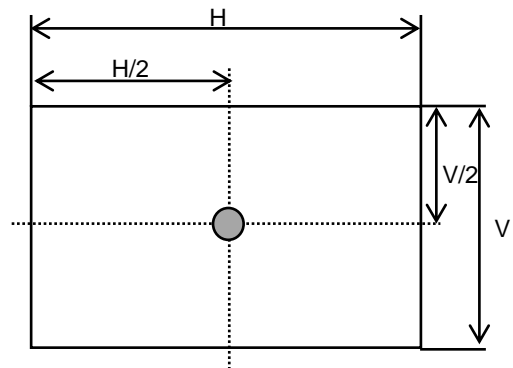

H : 337.92 mm
V : 270.34 mm
@ H,V : Active Area

- The **Gray to Gray response time** is defined as the following figure and shall be measured by switching the input signal for "Gray To Gray ".
 - Gray step : 5 Step
 - TGTG_AVR is the total average time at rising time and falling time for "Gray To Gray ".
 - By RD80S

Table 10. GTG Gray Table

Gray to Gray		Rising Time				
		G255	G191	G127	G63	G0
Falling Time	G255					
	G191					
	G127					
	G63					
	G0					

Product Specification

Response time is defined as the following figure and shall be measured by switching the input signal for "Gray(N)" and "Gray(M)".

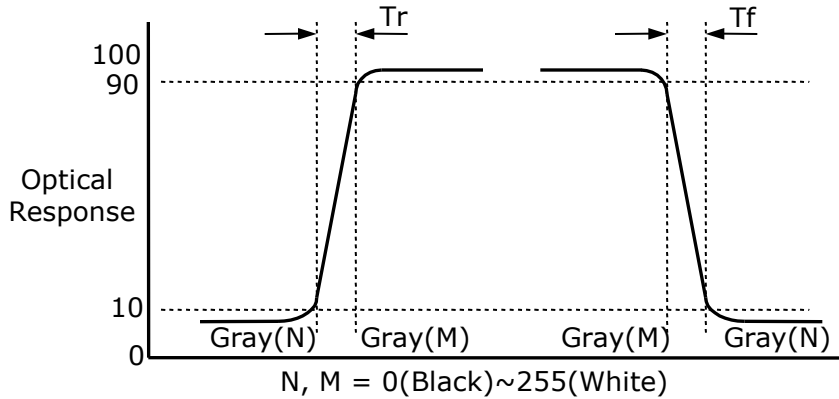

FIG 9. Response Time

5. Color shift is the angle at which the average color difference for all Macbeth is lower than 0.04.

For more information see FIG.9 **(By EZ Contrast)**

- Color difference ($\Delta u'v'$)

$$u' = \frac{4x}{-2x + 12y + 3} \quad v' = \frac{9y}{-2x + 12y + 3} \quad \Delta u'v' = \sqrt{(u'_1 - u'_2)^2 + (v'_1 - v'_2)^2}$$

$$Avg(\Delta u'v') = \frac{\sum_{i=1}^{24} (\Delta u'v')_i}{24}$$

u'_1, v'_1 : $u'v'$ value at viewing angle direction
 u'_2, v'_2 : $u'v'$ value at front ($\theta=0$)
i : Macbeth chart number (Define 23 page)

- Pattern size : 25% Box size
- Viewing angle direction of color shift : Horizontal, Vertical

6. Viewing angle is the angle at which the contrast ratio is greater than 10. The angles are determined for the horizontal or x axis and the vertical or y axis with respect to the z axis which is normal to the LCD surface. For more information see FIG.10 **(By PR880)**

7. GSR is the rate of gamma shift at up, down, left and right 60 degree viewing angle compare with center gamma. For more information see FIG.11 and FIG.12 **(By EZ Contrast)**

- GSR (δ_{Gamma}) is defined as :

$$GSR = \left(1 - \frac{\text{View angle Gamma Value (Up,Down,Reft, Light 60 Degree)}}{\text{Center Gamma Value (0 Degree)}} \right) \times 100$$

8. Gamma Value is approximately 2.2. For more information see Table 11.

Product Specification

Color shift is defined as the following test pattern and color.

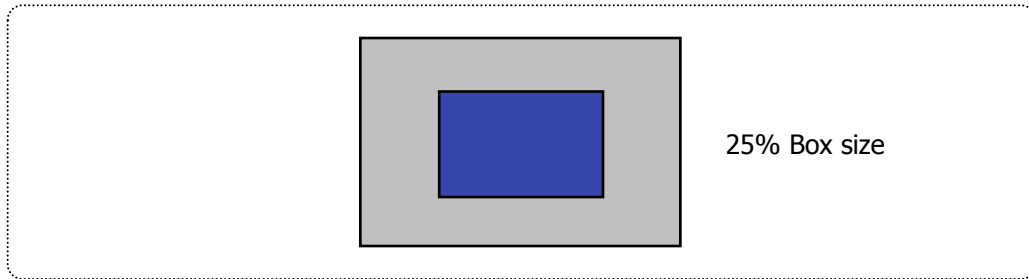

FIG.9 Color Shift Test Pattern

Average RGB values in Bruce RGB for Macbeth Chart

	Dark skin (i=1)	Light skin	Blue sky	Foliage	Blue flower	Bluish green
R	98	206	85	77	129	114
G	56	142	112	102	118	199
B	45	123	161	46	185	178
	Orange	Purplish blue	Moderate red	Purple	Yellow green	Orange yellow
R	219	56	211	76	160	230
G	104	69	67	39	193	162
B	24	174	87	86	58	29
	Blue	Green	Red	Yellow	Magenta	Cyan
R	26	72	197	241	207	35
G	32	148	27	212	62	126
B	145	65	37	36	151	172
	White	Neutral 8	Neutral 6.5	Neutral 5	Neutral 3.5	Black
R	240	206	155	110	63	22
G	240	206	155	110	63	22
B	240	206	155	110	63	22

Product Specification

Dimension of viewing angle range.

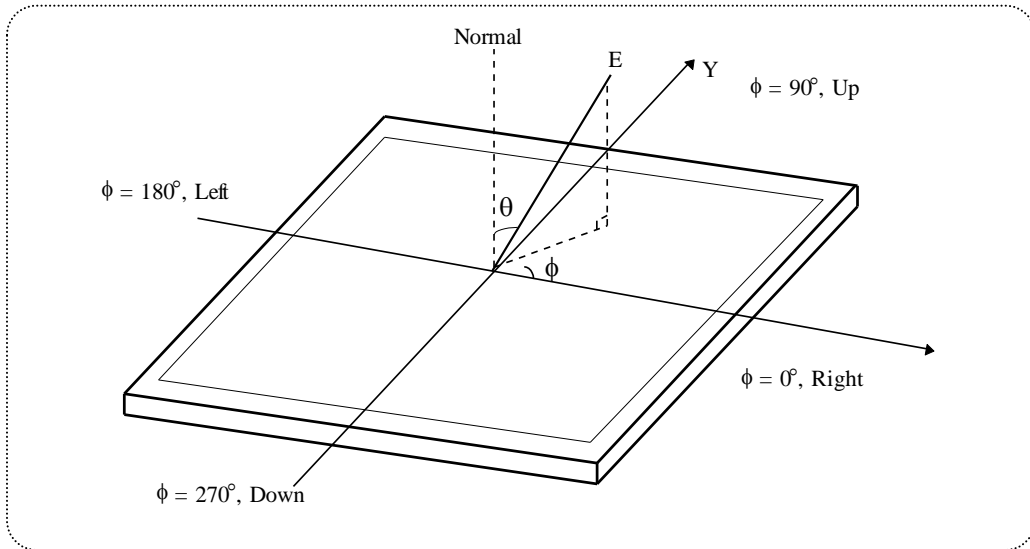

FIG.10 Viewing angle

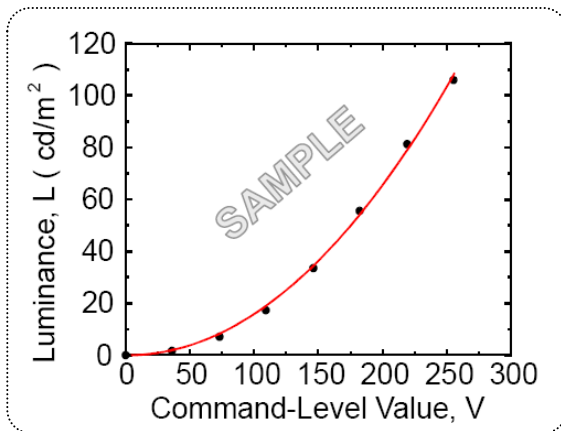

FIG.11 Sample Luminance vs. gray scale (using a 256 bit gray scale)

$$L = aV^r + L_b$$

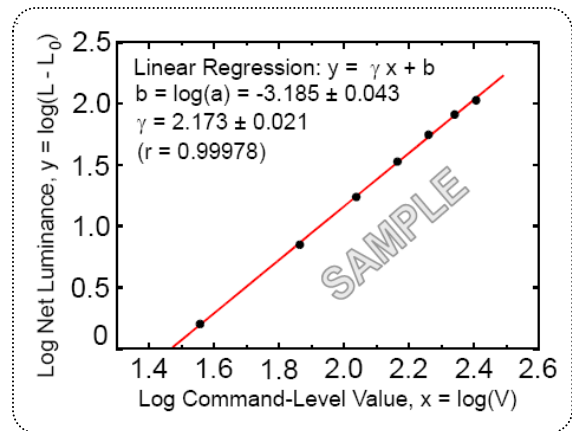

FIG.12 Sample Log-log plot of luminance vs. gray scale

$$\log(L - L_b) = r \log(V) + \log(a)$$

Here the Parameter a and γ relate the signal level V to the luminance L .
The GAMMA we calculate from the log-log representation (FIG.11)

Product Specification

Table 11. Gray Scale Specification

Gray Level	Relative Luminance [%] (Typ.)
0	0.11
31	1.08
63	4.72
95	11.49
127	21.66
159	35.45
191	53.00
223	74.48
255	100

Product Specification
5. Mechanical Characteristics

The contents provide general mechanical characteristics. In addition the figures in the next page are detailed mechanical drawing of the LCD.

Outline Dimension	Horizontal	368.0mm
	Vertical	306.0mm
	Depth	14.3mm
Bezel Area	Horizontal	341.5mm
	Vertical	274.6mm
Active Display Area	Horizontal	337.92mm
	Vertical	270.336mm
Weight(approximate)	1260g (typ.) , 1310g (max.)	
Surface Treatment	Hard coating(3H) Anti-Glare treatment of the front polarizer	

Notes : Please refer to a mechanic drawing in terms of tolerance at the next page.

Product Specification

<FRONT VIEW>

Note) Unit:[mm], General tolerance: $\pm 0.5\text{mm}$

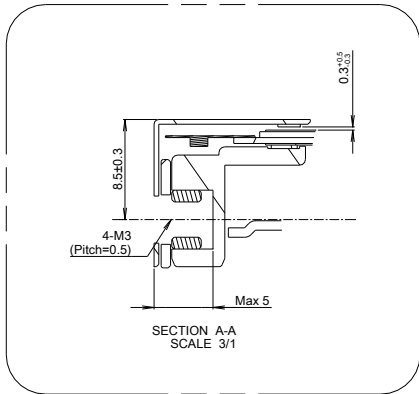
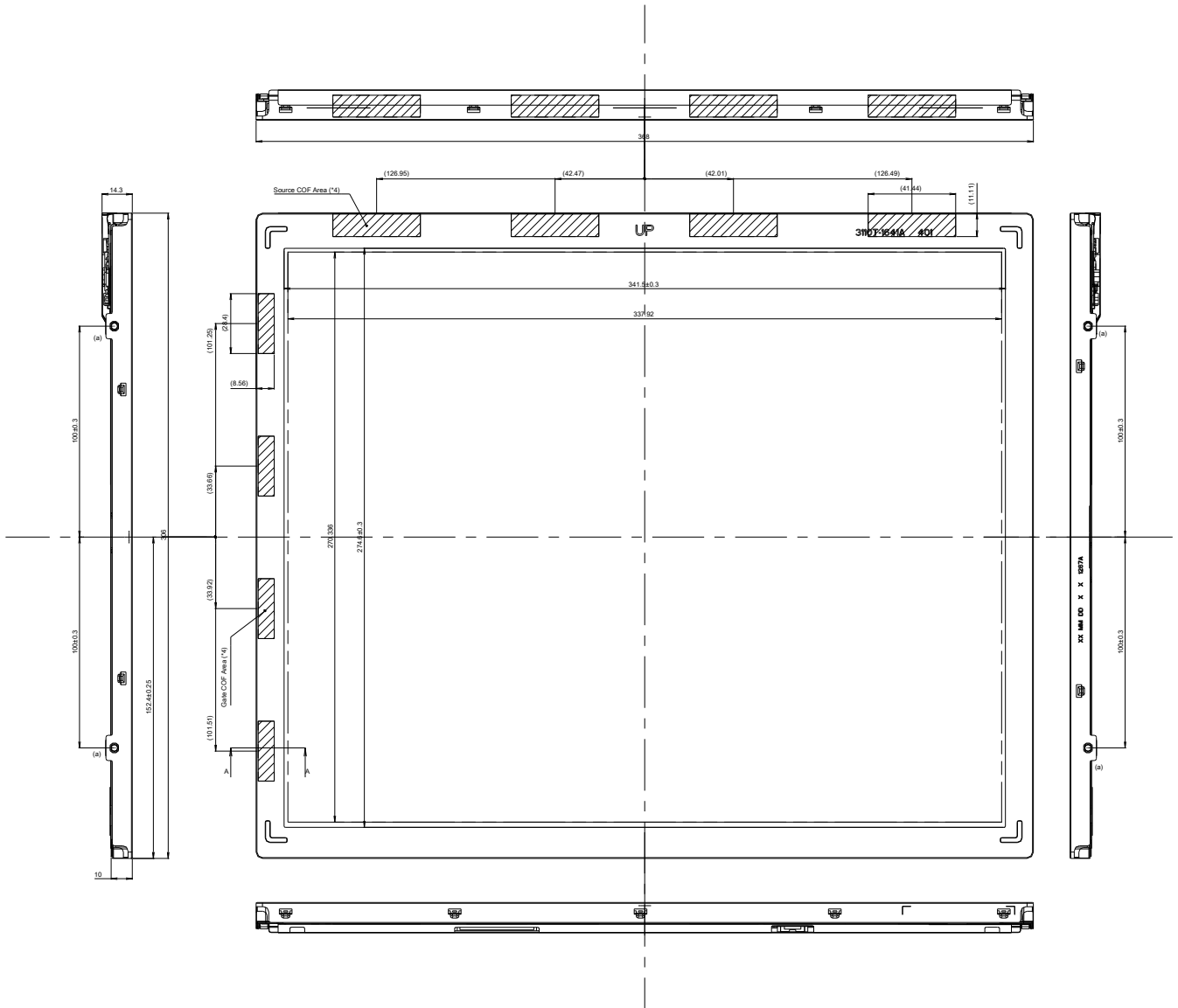

Product Specification

<REAR VIEW>

Note) Unit:[mm], General tolerance: $\pm 0.5\text{mm}$

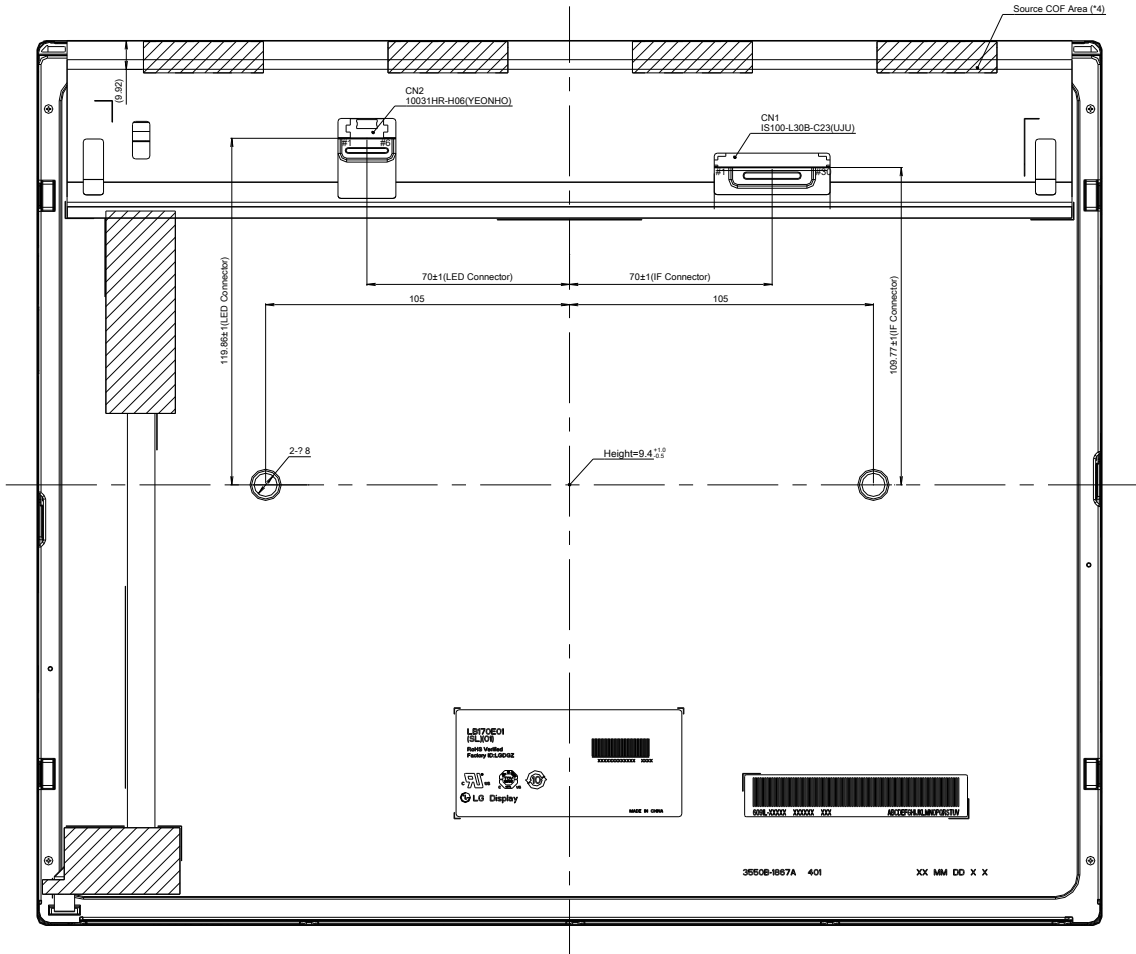

Notes

1. Unspecified tolerances are to be ± 0.5
2. Tilt and partial disposition tolerance of display area are as following.
 - (1) Y-direction : | A-B | ≤ 1.4
 - (2) X-direction : | C-D | ≤ 1.4

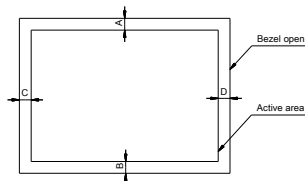

3. Torque of User Hole(Mount) : 3.0~4.0kgf.cm
4. I/F Connector Specification(CN1) : IS100-L30B-C23(UJU)
5. LED Connector Specification(CN2) : 10031HR-H06(YEONHO)
6. The COF area is weak & sensitive, so please don't press the COF area
7. Outline Dimension is not including Tape & Cover Shield thickness

Product Specification
6. Reliability

Environment test condition

No	Test Item	Condition
1	High temperature storage test	Ta= 80°C 240h
2	Low temperature storage test	Ta= -20°C 240h
3	High temperature operation test	Ta= 70°C 240h
4	Low temperature operation test	Ta= -10°C 240h
5	Vibration test (non-operating)	Wave form : random Vibration level : 1.00G RMS Bandwidth : 10-300Hz Duration : X, Y, Z, 10 min One time each direction
6	Shock test (non-operating)	Shock level : 100G Waveform : half sine wave, 2ms Direction : ±X, ±Y, ±Z One time each direction
7	Humidity condition Operation	Ta= 50 °C ,80%RH
8	Altitude operating storage / shipment	0 - 16,000 feet(4,876m) 0 - 40,000 feet(12,192m)

Note 1. Result Evaluation Criteria:

TFT-LCD panels test should take place after cooling enough at room temperature.

In the standard condition, there should be no particular problems that may affect the display function.

 ※. T_a= Ambient Temperature

Product Specification

7. International Standards

7-1. Safety

- a) UL 60950-1, Underwriters Laboratories Inc.
Information Technology Equipment - Safety - Part 1 : General Requirements.
- b) CAN/CSA -C22.2 No.60950-1-07, Canadian Standards Association.
Information Technology Equipment - Safety - Part 1 : General Requirements.
- c) EN 60950-1, European Committee for Electrotechnical Standardization (CENELEC).
Information Technology Equipment - Safety - Part 1 : General Requirements.
- d) IEC 60950-1, The International Electrotechnical Commission (IEC).
Information Technology Equipment - Safety - Part 1 : General Requirements

7-2. Environment

- a) RoHS, Directive 2011/65/EU of the European Parliament and of the council of 8 June 2011

Product Specification
8. Packing
8-1. Designation of Lot Mark

a) Lot Mark

A	B	C	D	E	F	G	H	I	J	K	L	M
---	---	---	---	---	---	---	---	---	---	---	---	---

A,B,C : SIZE(INCH)

E : MONTH

D : YEAR

F ~ M : SERIAL NO.

Note

1. YEAR

Year	2011	2012	2013	2014	2015	2016	2017	2018	2019	2020
Mark	A	B	C	D	E	F	G	H	J	K

2. MONTH

Month	Jan	Feb	Mar	Apr	May	Jun	Jul	Aug	Sep	Oct	Nov	Dec
Mark	1	2	3	4	5	6	7	8	9	A	B	C

b) Location of Lot Mark

Serial No. is printed on the label. The label is attached to the backside of the LCD module.
 This is subject to change without prior notice.

8-2. Packing Form

a) Package quantity in one box : 12 pcs

b) Box Size : 365 X 315 X 492mm

Product Specification

9. PRECAUTIONS

Please pay attention to the followings when you use this TFT LCD module.

9-1. MOUNTING PRECAUTIONS

- (1) You must mount a module using holes arranged in four corners or four sides.
- (2) You should consider the mounting structure so that uneven force (ex. Twisted stress) is not applied to the module. And the case on which a module is mounted should have sufficient strength so that external force is not transmitted directly to the module.
- (3) Please attach the surface transparent protective plate to the surface in order to protect the polarizer. Transparent protective plate should have sufficient strength in order to resist external force.
- (4) You should adopt a mounting structure to satisfy the temperature specification.
- (5) Acetic acid type and chlorine type materials for the cover case are not desirable because the former generates corrosive gas of attacking the polarizer at high temperature and the latter causes circuit break by electro-chemical reaction.
- (6) Do not touch, push or rub the exposed polarizers with glass, tweezers or anything harder than HB pencil lead. And please do not rub with dust clothes with chemical treatment. Do not touch the surface of polarizer for bare hand or greasy cloth. (Some cosmetics are detrimental to the polarizer.)
- (7) When the surface becomes dusty, please wipe gently with absorbent cotton or other soft materials like chamois soaked with petroleum benzene. Normal-hexane is recommended for cleaning the adhesives used to attach front / rear polarizers. Do not use acetone, toluene and alcohol because they cause chemical damage to the polarizer.
- (8) Wipe off saliva or water drops as soon as possible. Their long time contact with polarizer causes deformations and color fading.
- (9) Do not open the case because inside circuits do not have sufficient strength.
- (10) As the IPS panel is sensitive & slim, please recommend the metal frame of the system supports the panel by the double side-mount.

9-2. OPERATING PRECAUTIONS

- (1) The spike noise causes the mis-operation of circuits. It should be lower than following voltage :
 $V = \pm 200\text{mV}$ (Over and under shoot voltage)
- (2) Response time depends on the temperature. (In lower temperature, it becomes longer.)
- (3) Brightness depends on the temperature. (In lower temperature, it becomes lower.)
And in lower temperature, response time (required time that brightness is stable after turned on) becomes longer.
- (4) Be careful for condensation at sudden temperature change. Condensation makes damage to polarizer or electrical contacted parts. And after fading condensation, smear or spot will occur.
- (5) When fixed patterns are displayed for a long time, remnant image is likely to occur.
- (6) Module has high frequency circuits. Sufficient suppression to the electromagnetic interference shall be done by system manufacturers. Grounding and shielding methods may be important to minimize the interference.
- (7) Please do not give any mechanical and/or acoustical impact to LCM. Otherwise, LCM can't be operated its full characteristics perfectly.
- (8) A screw which is fastened up the steel should be a machine screw.
(if not, it causes metallic foreign material and deal LCM a fatal blow)
- (9) Please do not set LCD on its edge.
- (10) When LCMs are used for public display defects such as Yogore, image sticking can not be guaranteed.
- (11) LCMs cannot support "Interlaced Scan Method"

Product Specification

9-3. ELECTROSTATIC DISCHARGE CONTROL

Since a module is composed of electronic circuits, it is not strong to electrostatic discharge. Make certain that treatment persons are connected to ground through wrist band etc. And don't touch interface pin directly.

9-4. PRECAUTIONS FOR STRONG LIGHT EXPOSURE

Strong light exposure causes degradation of polarizer and color filter.

9-5. STORAGE

When storing modules as spares for a long time, the following precautions are necessary.

- (1) Store them in a dark place. Do not expose the module to sunlight or fluorescent light. Keep the temperature between 5°C and 35°C at normal humidity.
- (2) The polarizer surface should not come in contact with any other object.
It is recommended that they be stored in the container in which they were shipped.

9-6. HANDLING PRECAUTIONS FOR PROTECTION FILM

- (1) The protection film is attached to the bezel with a small masking tape.
When the protection film is peeled off, static electricity is generated between the film and polarizer.
This should be peeled off slowly and carefully by people who are electrically grounded and with well ion-blown equipment or in such a condition, etc.
- (2) When the module with protection film attached is stored for a long time, sometimes there remains a very small amount of glue still on the bezel after the protection film is peeled off.
- (3) You can remove the glue easily. When the glue remains on the bezel surface or its vestige is recognized, please wipe them off with absorbent cotton waste or other soft material like chamois soaked with normal-hexane.

Our company network supports you worldwide with offices in Germany, Austria, Switzerland, the UK and the USA. For more information please contact:

Headquarters

Germany



FORTEC Elektronik AG

Lechwiesenstr. 9
86899 Landsberg am Lech

Phone: +49 8191 91172-0
E-Mail: sales@forteca.de
Internet: www.forteca.de

Fortec Group Members

Austria



FORTEC Elektronik AG

Office Vienna

Nuschinggasse 12
1230 Wien

Phone: +43 1 8673492-0
E-Mail: office@fortec.at
Internet: www.fortec.at

Germany



Distec GmbH

Augsburger Str. 2b
82110 Germering

Phone: +49 89 894363-0
E-Mail: info@distec.de
Internet: www.distec.de

Switzerland



ALTRAC AG

Bahnhofstraße 3
5436 Würenlos

Phone: +41 44 7446111
E-Mail: info@altrac.ch
Internet: www.altrac.ch

United Kingdom



Display Technology Ltd.

Osprey House, 1 Osprey Court
Hichingbrooke Business Park
Huntingdon, Cambridgeshire, PE29 6FN

Phone: +44 1480 411600
E-Mail: info@displaytechnology.co.uk
Internet: www.displaytechnology.co.uk

USA



Apollo Display Technologies, Corp.

87 Raynor Avenue,
Unit 1 Ronkonkoma,
NY 11779

Phone: +1 631 5804360
E-Mail: info@apolloDisplays.com
Internet: www.apolloDisplays.com