



OUR GLOBAL
COMPETENCE
CENTRES

 APOLLO DISPLAY
TECHNOLOGIES



 DISTEC



 DISPLAY
TECHNOLOGY



Datasheet

AUO

; % ' < 5 B\$%\$

WÜEGFHU



Product Specification

AU OPTRONICS CORPORATION

() Preliminary Specifications

(V) Final Specifications

Module	13.3" FHD Color TFT-LCD
Model Name	G133HAN01.0
Note	LED backlight with driving circuit design

Customer	Date
Checked & Approved by	Date
<p>Note: This Specification is subject to change without notice.</p>	

Approved by	Date
<u>Sean Lin</u>	<u>2017/12/1</u>
Prepared by	Date
<u>CH Tsai</u>	<u>2017/12/1</u>
<p>GD BU Marketing Division AU Optronics Corporation</p>	



Product Specification

AU OPTRONICS CORPORATION

Contents

1. Handling Precautions	5
2. General Description	6
2.1 General Specification	6
2.2 Optical Characteristics	7
3. Functional Block Diagram	11
4. Absolute Maximum Ratings	12
4.1 Absolute Ratings of TFT LCD Module.....	12
4.2 Absolute Ratings of Environment	12
5. Electrical Characteristics	13
5.1 TFT LCD Module	13
5.2 Backlight Unit	15
6. Signal Interface Characteristic	16
6.1 Pixel Format Image	16
6.2 The Input Data Format	17
6.3 Signal Description (CN1).....	18
6.4 Interface Timing (LVDS).....	19
6.5 Power ON/OFF Sequence	20
7. Connector & Pin Assignment	21
7.1 TFT LCD Module	21
7.2 Backlight Unit	22
8. Panel Reliability Test	24
9. Label and Package	25
9.1 Shipping Label Format	25
9.2 Carton Package	25
10 .Mechanical Characteristics	26
10.1 LCM Outline Dimension (Front View)	26
10.2 LCM Outline Dimension (Rear View).....	27



Product Specification

AU OPTRONICS CORPORATION

Record of Revision

Version and Date	Page	Old Description	New Description	Remark																																																																																															
1.0 2016/10/28	All	First Final specification																																																																																																	
2.0 2017/11/21	5	<table border="1"> <tr> <td>Support Color</td> <td>-</td> <td>16.7M Colors (RGB 8bits)</td> </tr> <tr> <td>Temperature Range (Operating)</td> <td>(°C)</td> <td>0 to +70</td> </tr> <tr> <td>Storage Temperature (Non-Operating)</td> <td>(°C)</td> <td>-30 to +70</td> </tr> </table>	Support Color	-	16.7M Colors (RGB 8bits)	Temperature Range (Operating)	(°C)	0 to +70	Storage Temperature (Non-Operating)	(°C)	-30 to +70	<table border="1"> <tr> <td>Support Color</td> <td>-</td> <td>16.7M Colors (RGB 8bits)</td> </tr> <tr> <td>Temperature Range (Operating)</td> <td>(°C)</td> <td>0 to +70</td> </tr> <tr> <td>Storage Temperature (Non-Operating)</td> <td>(°C)</td> <td>-30 to +70</td> </tr> </table>	Support Color	-	16.7M Colors (RGB 8bits)	Temperature Range (Operating)	(°C)	0 to +70	Storage Temperature (Non-Operating)	(°C)	-30 to +70																																																																														
	Support Color	-	16.7M Colors (RGB 8bits)																																																																																																
	Temperature Range (Operating)	(°C)	0 to +70																																																																																																
Storage Temperature (Non-Operating)	(°C)	-30 to +70																																																																																																	
Support Color	-	16.7M Colors (RGB 8bits)																																																																																																	
Temperature Range (Operating)	(°C)	0 to +70																																																																																																	
Storage Temperature (Non-Operating)	(°C)	-30 to +70																																																																																																	
11	<table border="1"> <thead> <tr> <th>Item</th> <th>Symbol</th> <th>Min.</th> <th>Max.</th> <th>Unit</th> <th>Conditions</th> </tr> </thead> <tbody> <tr> <td>Operating temp.</td> <td>TOP</td> <td>0</td> <td>+70</td> <td>(°C)</td> <td>Note 4.1</td> </tr> <tr> <td>Operating humidity</td> <td>PHUM</td> <td>0</td> <td>90</td> <td>(%)RH</td> <td>Note 4.1</td> </tr> <tr> <td>Storage Temperature</td> <td>TST</td> <td>0</td> <td>+70</td> <td>(°C)</td> <td>Note 4.1</td> </tr> <tr> <td>Storage Humidity</td> <td>PHST</td> <td>0</td> <td>90</td> <td>(%)RH</td> <td>Note 4.1</td> </tr> </tbody> </table>	Item	Symbol	Min.	Max.	Unit	Conditions	Operating temp.	TOP	0	+70	(°C)	Note 4.1	Operating humidity	PHUM	0	90	(%)RH	Note 4.1	Storage Temperature	TST	0	+70	(°C)	Note 4.1	Storage Humidity	PHST	0	90	(%)RH	Note 4.1	<table border="1"> <thead> <tr> <th>Item</th> <th>Symbol</th> <th>Min.</th> <th>Max.</th> <th>Unit</th> <th>Conditions</th> </tr> </thead> <tbody> <tr> <td>Operating temp.</td> <td>TOP</td> <td>0</td> <td>+70</td> <td>(°C)</td> <td>Note 4.1</td> </tr> <tr> <td>Operating humidity</td> <td>PHUM</td> <td>0</td> <td>90</td> <td>(%)RH</td> <td>Note 4.1</td> </tr> <tr> <td>Storage Temperature</td> <td>TST</td> <td>0</td> <td>+70</td> <td>(°C)</td> <td>Note 4.1</td> </tr> <tr> <td>Storage Humidity</td> <td>PHST</td> <td>0</td> <td>90</td> <td>(%)RH</td> <td>Note 4.1</td> </tr> </tbody> </table>	Item	Symbol	Min.	Max.	Unit	Conditions	Operating temp.	TOP	0	+70	(°C)	Note 4.1	Operating humidity	PHUM	0	90	(%)RH	Note 4.1	Storage Temperature	TST	0	+70	(°C)	Note 4.1	Storage Humidity	PHST	0	90	(%)RH	Note 4.1																																					
Item	Symbol	Min.	Max.	Unit	Conditions																																																																																														
Operating temp.	TOP	0	+70	(°C)	Note 4.1																																																																																														
Operating humidity	PHUM	0	90	(%)RH	Note 4.1																																																																																														
Storage Temperature	TST	0	+70	(°C)	Note 4.1																																																																																														
Storage Humidity	PHST	0	90	(%)RH	Note 4.1																																																																																														
Item	Symbol	Min.	Max.	Unit	Conditions																																																																																														
Operating temp.	TOP	0	+70	(°C)	Note 4.1																																																																																														
Operating humidity	PHUM	0	90	(%)RH	Note 4.1																																																																																														
Storage Temperature	TST	0	+70	(°C)	Note 4.1																																																																																														
Storage Humidity	PHST	0	90	(%)RH	Note 4.1																																																																																														
18	<p>4.1.1 Timing Characteristics</p> <p>Symbolically, the timing characteristics are defined as follows:</p> <table border="1"> <thead> <tr> <th>Parameter</th> <th>Symbol</th> <th>Min.</th> <th>Typ.</th> <th>Max.</th> <th>Unit</th> </tr> </thead> <tbody> <tr> <td>Frame Rate</td> <td>F_{rate}</td> <td>40</td> <td>60</td> <td>80</td> <td>Hz</td> </tr> <tr> <td>Horizontal Frequency</td> <td>F_h</td> <td>15.75</td> <td>15.735</td> <td>15.75</td> <td>kHz</td> </tr> <tr> <td>Vertical Frequency</td> <td>F_v</td> <td>59.94</td> <td>60</td> <td>60.06</td> <td>Hz</td> </tr> <tr> <td>Horizontal Sync</td> <td>H_{sync}</td> <td>100</td> <td>100</td> <td>100</td> <td>ns</td> </tr> <tr> <td>Vertical Sync</td> <td>V_{sync}</td> <td>100</td> <td>100</td> <td>100</td> <td>ns</td> </tr> <tr> <td>Horizontal Setup</td> <td>H_{setup}</td> <td>100</td> <td>110</td> <td>120</td> <td>ns</td> </tr> <tr> <td>Vertical Setup</td> <td>V_{setup}</td> <td>100</td> <td>110</td> <td>120</td> <td>ns</td> </tr> </tbody> </table> <p>Note: The timing characteristics are defined as follows:</p> <ul style="list-style-type: none"> Note 1: The timing characteristics are defined as follows. Note 2: The timing characteristics are defined as follows. Note 3: The timing characteristics are defined as follows. Note 4: The timing characteristics are defined as follows. Note 5: The timing characteristics are defined as follows. Note 6: The timing characteristics are defined as follows. Note 7: The timing characteristics are defined as follows. Note 8: The timing characteristics are defined as follows. Note 9: The timing characteristics are defined as follows. Note 10: The timing characteristics are defined as follows. 	Parameter	Symbol	Min.	Typ.	Max.	Unit	Frame Rate	F _{rate}	40	60	80	Hz	Horizontal Frequency	F _h	15.75	15.735	15.75	kHz	Vertical Frequency	F _v	59.94	60	60.06	Hz	Horizontal Sync	H _{sync}	100	100	100	ns	Vertical Sync	V _{sync}	100	100	100	ns	Horizontal Setup	H _{setup}	100	110	120	ns	Vertical Setup	V _{setup}	100	110	120	ns	<p>4.1.1 Timing Characteristics</p> <p>Symbolically, the timing characteristics are defined as follows:</p> <table border="1"> <thead> <tr> <th>Parameter</th> <th>Symbol</th> <th>Min.</th> <th>Typ.</th> <th>Max.</th> <th>Unit</th> </tr> </thead> <tbody> <tr> <td>Frame Rate</td> <td>F_{rate}</td> <td>40</td> <td>60</td> <td>80</td> <td>Hz</td> </tr> <tr> <td>Horizontal Frequency</td> <td>F_h</td> <td>15.75</td> <td>15.735</td> <td>15.75</td> <td>kHz</td> </tr> <tr> <td>Vertical Frequency</td> <td>F_v</td> <td>59.94</td> <td>60</td> <td>60.06</td> <td>Hz</td> </tr> <tr> <td>Horizontal Sync</td> <td>H_{sync}</td> <td>100</td> <td>100</td> <td>100</td> <td>ns</td> </tr> <tr> <td>Vertical Sync</td> <td>V_{sync}</td> <td>100</td> <td>100</td> <td>100</td> <td>ns</td> </tr> <tr> <td>Horizontal Setup</td> <td>H_{setup}</td> <td>100</td> <td>110</td> <td>120</td> <td>ns</td> </tr> <tr> <td>Vertical Setup</td> <td>V_{setup}</td> <td>100</td> <td>110</td> <td>120</td> <td>ns</td> </tr> </tbody> </table> <p>Note: The timing characteristics are defined as follows:</p> <ul style="list-style-type: none"> Note 1: The timing characteristics are defined as follows. Note 2: The timing characteristics are defined as follows. Note 3: The timing characteristics are defined as follows. Note 4: The timing characteristics are defined as follows. Note 5: The timing characteristics are defined as follows. Note 6: The timing characteristics are defined as follows. Note 7: The timing characteristics are defined as follows. Note 8: The timing characteristics are defined as follows. Note 9: The timing characteristics are defined as follows. Note 10: The timing characteristics are defined as follows. 	Parameter	Symbol	Min.	Typ.	Max.	Unit	Frame Rate	F _{rate}	40	60	80	Hz	Horizontal Frequency	F _h	15.75	15.735	15.75	kHz	Vertical Frequency	F _v	59.94	60	60.06	Hz	Horizontal Sync	H _{sync}	100	100	100	ns	Vertical Sync	V _{sync}	100	100	100	ns	Horizontal Setup	H _{setup}	100	110	120	ns	Vertical Setup	V _{setup}	100	110	120	ns	
Parameter	Symbol	Min.	Typ.	Max.	Unit																																																																																														
Frame Rate	F _{rate}	40	60	80	Hz																																																																																														
Horizontal Frequency	F _h	15.75	15.735	15.75	kHz																																																																																														
Vertical Frequency	F _v	59.94	60	60.06	Hz																																																																																														
Horizontal Sync	H _{sync}	100	100	100	ns																																																																																														
Vertical Sync	V _{sync}	100	100	100	ns																																																																																														
Horizontal Setup	H _{setup}	100	110	120	ns																																																																																														
Vertical Setup	V _{setup}	100	110	120	ns																																																																																														
Parameter	Symbol	Min.	Typ.	Max.	Unit																																																																																														
Frame Rate	F _{rate}	40	60	80	Hz																																																																																														
Horizontal Frequency	F _h	15.75	15.735	15.75	kHz																																																																																														
Vertical Frequency	F _v	59.94	60	60.06	Hz																																																																																														
Horizontal Sync	H _{sync}	100	100	100	ns																																																																																														
Vertical Sync	V _{sync}	100	100	100	ns																																																																																														
Horizontal Setup	H _{setup}	100	110	120	ns																																																																																														
Vertical Setup	V _{setup}	100	110	120	ns																																																																																														
3.0 2017/12/1	6	<table border="1"> <tr> <td>Support Color</td> <td>-</td> <td>16.7M Colors (RGB 8bits)</td> </tr> <tr> <td>Temperature Range (Operating)</td> <td>(°C)</td> <td>0 to +70</td> </tr> <tr> <td>Storage Temperature (Non-Operating)</td> <td>(°C)</td> <td>-30 to +70</td> </tr> </table>	Support Color	-	16.7M Colors (RGB 8bits)	Temperature Range (Operating)	(°C)	0 to +70	Storage Temperature (Non-Operating)	(°C)	-30 to +70	<table border="1"> <tr> <td>Support Color</td> <td>-</td> <td>16.7M Colors (RGB 8bits)</td> </tr> <tr> <td>Temperature Range (Operating)</td> <td>(°C)</td> <td>0 to +70</td> </tr> <tr> <td>Storage Temperature (Non-Operating)</td> <td>(°C)</td> <td>-30 to +70</td> </tr> </table>	Support Color	-	16.7M Colors (RGB 8bits)	Temperature Range (Operating)	(°C)	0 to +70	Storage Temperature (Non-Operating)	(°C)	-30 to +70																																																																														
	Support Color	-	16.7M Colors (RGB 8bits)																																																																																																
Temperature Range (Operating)	(°C)	0 to +70																																																																																																	
Storage Temperature (Non-Operating)	(°C)	-30 to +70																																																																																																	
Support Color	-	16.7M Colors (RGB 8bits)																																																																																																	
Temperature Range (Operating)	(°C)	0 to +70																																																																																																	
Storage Temperature (Non-Operating)	(°C)	-30 to +70																																																																																																	
12	<p>4.2 Absolute Ratings of Environment</p> <table border="1"> <thead> <tr> <th>Item</th> <th>Symbol</th> <th>Min.</th> <th>Max.</th> <th>Unit</th> <th>Conditions</th> </tr> </thead> <tbody> <tr> <td>Operating temp.</td> <td>TOP</td> <td>-20</td> <td>+70</td> <td>(°C)</td> <td>Note 4.1</td> </tr> <tr> <td>Operating humidity</td> <td>PHUM</td> <td>0</td> <td>90</td> <td>(%)RH</td> <td>Note 4.1</td> </tr> <tr> <td>Storage Temperature</td> <td>TST</td> <td>-30</td> <td>+70</td> <td>(°C)</td> <td>Note 4.1</td> </tr> <tr> <td>Storage Humidity</td> <td>PHST</td> <td>0</td> <td>90</td> <td>(%)RH</td> <td>Note 4.1</td> </tr> </tbody> </table>	Item	Symbol	Min.	Max.	Unit	Conditions	Operating temp.	TOP	-20	+70	(°C)	Note 4.1	Operating humidity	PHUM	0	90	(%)RH	Note 4.1	Storage Temperature	TST	-30	+70	(°C)	Note 4.1	Storage Humidity	PHST	0	90	(%)RH	Note 4.1	<p>4.2 Absolute Ratings of Environment</p> <table border="1"> <thead> <tr> <th>Item</th> <th>Symbol</th> <th>Min.</th> <th>Max.</th> <th>Unit</th> <th>Conditions</th> </tr> </thead> <tbody> <tr> <td>Operating temp.</td> <td>TOP</td> <td>-20</td> <td>+70</td> <td>(°C)</td> <td>Note 4.1</td> </tr> <tr> <td>Operating humidity</td> <td>PHUM</td> <td>0</td> <td>90</td> <td>(%)RH</td> <td>Note 4.1</td> </tr> <tr> <td>Storage Temperature</td> <td>TST</td> <td>-30</td> <td>+70</td> <td>(°C)</td> <td>Note 4.1</td> </tr> <tr> <td>Storage Humidity</td> <td>PHST</td> <td>0</td> <td>90</td> <td>(%)RH</td> <td>Note 4.1</td> </tr> </tbody> </table>	Item	Symbol	Min.	Max.	Unit	Conditions	Operating temp.	TOP	-20	+70	(°C)	Note 4.1	Operating humidity	PHUM	0	90	(%)RH	Note 4.1	Storage Temperature	TST	-30	+70	(°C)	Note 4.1	Storage Humidity	PHST	0	90	(%)RH	Note 4.1																																					
Item	Symbol	Min.	Max.	Unit	Conditions																																																																																														
Operating temp.	TOP	-20	+70	(°C)	Note 4.1																																																																																														
Operating humidity	PHUM	0	90	(%)RH	Note 4.1																																																																																														
Storage Temperature	TST	-30	+70	(°C)	Note 4.1																																																																																														
Storage Humidity	PHST	0	90	(%)RH	Note 4.1																																																																																														
Item	Symbol	Min.	Max.	Unit	Conditions																																																																																														
Operating temp.	TOP	-20	+70	(°C)	Note 4.1																																																																																														
Operating humidity	PHUM	0	90	(%)RH	Note 4.1																																																																																														
Storage Temperature	TST	-30	+70	(°C)	Note 4.1																																																																																														
Storage Humidity	PHST	0	90	(%)RH	Note 4.1																																																																																														
24	<table border="1"> <thead> <tr> <th>Item</th> <th>Required Condition</th> <th>Note</th> </tr> </thead> <tbody> <tr> <td>Temperature Humidity</td> <td>Top: 0°C, 90%RH; 300h</td> <td></td> </tr> <tr> <td>High temperature operation</td> <td>0 to 70°C, 30%RH</td> <td></td> </tr> <tr> <td>Low temperature operation</td> <td>0 to 70°C, 30%RH</td> <td>Note 1.2</td> </tr> <tr> <td>High temperature storage</td> <td>0 to 70°C, 30%RH</td> <td>Note 1.2</td> </tr> <tr> <td>Low temperature storage</td> <td>0 to 70°C, 30%RH</td> <td>Note 1.2</td> </tr> <tr> <td>Vibration test (non-operating)</td> <td>100 to 2000 Hz, 0.5 mm/s² (random), 30 min/axis (X, Y, Z)</td> <td>Note 1.2</td> </tr> <tr> <td>Shock test (non-operating)</td> <td>1500 ms, 10 g, 1000 Hz, 10 ms (square wave), 1000 Hz, 10 g, 1000 Hz, 10 ms (square wave)</td> <td>Note 1.2</td> </tr> <tr> <td>ESD</td> <td>ESD: 2kV (air discharge), 15kV (contact discharge), 15kV (100pF discharge), 15kV (100pF discharge)</td> <td>Note 1.2</td> </tr> </tbody> </table>	Item	Required Condition	Note	Temperature Humidity	Top: 0°C, 90%RH; 300h		High temperature operation	0 to 70°C, 30%RH		Low temperature operation	0 to 70°C, 30%RH	Note 1.2	High temperature storage	0 to 70°C, 30%RH	Note 1.2	Low temperature storage	0 to 70°C, 30%RH	Note 1.2	Vibration test (non-operating)	100 to 2000 Hz, 0.5 mm/s ² (random), 30 min/axis (X, Y, Z)	Note 1.2	Shock test (non-operating)	1500 ms, 10 g, 1000 Hz, 10 ms (square wave), 1000 Hz, 10 g, 1000 Hz, 10 ms (square wave)	Note 1.2	ESD	ESD: 2kV (air discharge), 15kV (contact discharge), 15kV (100pF discharge), 15kV (100pF discharge)	Note 1.2	<table border="1"> <thead> <tr> <th>Item</th> <th>Required Condition</th> <th>Note</th> </tr> </thead> <tbody> <tr> <td>Temperature Humidity</td> <td>Top: 0°C, 90%RH; 300h</td> <td></td> </tr> <tr> <td>High temperature operation</td> <td>0 to 70°C, 30%RH</td> <td></td> </tr> <tr> <td>Low temperature operation</td> <td>0 to 70°C, 30%RH</td> <td>Note 1.2</td> </tr> <tr> <td>High temperature storage</td> <td>0 to 70°C, 30%RH</td> <td>Note 1.2</td> </tr> <tr> <td>Low temperature storage</td> <td>0 to 70°C, 30%RH</td> <td>Note 1.2</td> </tr> <tr> <td>Vibration test (non-operating)</td> <td>100 to 2000 Hz, 0.5 mm/s² (random), 30 min/axis (X, Y, Z)</td> <td>Note 1.2</td> </tr> <tr> <td>Shock test (non-operating)</td> <td>1500 ms, 10 g, 1000 Hz, 10 ms (square wave), 1000 Hz, 10 g, 1000 Hz, 10 ms (square wave)</td> <td>Note 1.2</td> </tr> <tr> <td>ESD</td> <td>ESD: 2kV (air discharge), 15kV (contact discharge), 15kV (100pF discharge), 15kV (100pF discharge)</td> <td>Note 1.2</td> </tr> </tbody> </table>	Item	Required Condition	Note	Temperature Humidity	Top: 0°C, 90%RH; 300h		High temperature operation	0 to 70°C, 30%RH		Low temperature operation	0 to 70°C, 30%RH	Note 1.2	High temperature storage	0 to 70°C, 30%RH	Note 1.2	Low temperature storage	0 to 70°C, 30%RH	Note 1.2	Vibration test (non-operating)	100 to 2000 Hz, 0.5 mm/s ² (random), 30 min/axis (X, Y, Z)	Note 1.2	Shock test (non-operating)	1500 ms, 10 g, 1000 Hz, 10 ms (square wave), 1000 Hz, 10 g, 1000 Hz, 10 ms (square wave)	Note 1.2	ESD	ESD: 2kV (air discharge), 15kV (contact discharge), 15kV (100pF discharge), 15kV (100pF discharge)	Note 1.2																																											
Item	Required Condition	Note																																																																																																	
Temperature Humidity	Top: 0°C, 90%RH; 300h																																																																																																		
High temperature operation	0 to 70°C, 30%RH																																																																																																		
Low temperature operation	0 to 70°C, 30%RH	Note 1.2																																																																																																	
High temperature storage	0 to 70°C, 30%RH	Note 1.2																																																																																																	
Low temperature storage	0 to 70°C, 30%RH	Note 1.2																																																																																																	
Vibration test (non-operating)	100 to 2000 Hz, 0.5 mm/s ² (random), 30 min/axis (X, Y, Z)	Note 1.2																																																																																																	
Shock test (non-operating)	1500 ms, 10 g, 1000 Hz, 10 ms (square wave), 1000 Hz, 10 g, 1000 Hz, 10 ms (square wave)	Note 1.2																																																																																																	
ESD	ESD: 2kV (air discharge), 15kV (contact discharge), 15kV (100pF discharge), 15kV (100pF discharge)	Note 1.2																																																																																																	
Item	Required Condition	Note																																																																																																	
Temperature Humidity	Top: 0°C, 90%RH; 300h																																																																																																		
High temperature operation	0 to 70°C, 30%RH																																																																																																		
Low temperature operation	0 to 70°C, 30%RH	Note 1.2																																																																																																	
High temperature storage	0 to 70°C, 30%RH	Note 1.2																																																																																																	
Low temperature storage	0 to 70°C, 30%RH	Note 1.2																																																																																																	
Vibration test (non-operating)	100 to 2000 Hz, 0.5 mm/s ² (random), 30 min/axis (X, Y, Z)	Note 1.2																																																																																																	
Shock test (non-operating)	1500 ms, 10 g, 1000 Hz, 10 ms (square wave), 1000 Hz, 10 g, 1000 Hz, 10 ms (square wave)	Note 1.2																																																																																																	
ESD	ESD: 2kV (air discharge), 15kV (contact discharge), 15kV (100pF discharge), 15kV (100pF discharge)	Note 1.2																																																																																																	



Product Specification

AU OPTRONICS CORPORATION

AUO Confidential
For DISTEC Internal Use Only
20190725 16:44:39

AUO Confidential
For DISTEC Internal Use Only
20190725 16:44:39

AUO Confidential
For DISTEC Internal Use Only
20190725 16:44:39

AUO Confidential
For DISTEC Internal Use Only
20190725 16:44:39



Product Specification

AU OPTRONICS CORPORATION

1. Handling Precautions

- 1) Since front polarizer is easily damaged, please be cautious and not to scratch it.
- 2) Be sure to turn off power supply when inserting or disconnecting from input connector.
- 3) Wipe off water drop immediately. Long contact with water may cause discoloration or spots.
- 4) When the panel surface is soiled, wipe it with absorbent cotton or soft cloth.
- 5) Since the panel is made of glass, it may be broken or cracked if dropped or bumped on hard surface.
- 6) To avoid ESD (Electro Static Discharge) damage, be sure to ground yourself before handling TFT-LCD Module.
- 7) Do not open nor modify the module assembly.
- 8) Do not press the reflector sheet at the back of the module to any direction.
- 9) In case if a module has to be put back into the packing container slot after it was taken out from the container, do not press the center of the LED light bar edge. Instead, press at the far ends of the LED light bar edge softly. Otherwise the TFT Module may be damaged.
- 10) At the insertion or removal of the Signal Interface Connector, be sure not to rotate nor tilt the Interface Connector of the TFT Module.
- 11) TFT-LCD Module is not allowed to be twisted & bent even force is added on module in a very short time. Please design your display product well to avoid external force applying to module by end-user directly.
- 12) Small amount of materials without flammability grade are used in the TFT-LCD module. The TFT-LCD module should be supplied by power complied with requirements of Limited Power Source (IEC60950-1 or UL60950-1), or be applied exemption.
- 13) Severe temperature condition may result in different luminance, response time and lamp ignition voltage.
- 14) Continuous operating TFT-LCD display under low temperature environment may accelerate lamp exhaustion and reduce luminance dramatically.
- 15) The data on this specification sheet is applicable when LCD module is placed in landscape position.
- 16) Continuous displaying fixed pattern may induce image sticking. It's recommended to use screen saver or shuffle content periodically if fixed pattern is displayed on the screen.



Product Specification

AU OPTRONICS CORPORATION

2. General Description

G133HAN01.0 is a Color Active Matrix Liquid Crystal Display composed of a TFT LCD panel, a driver circuit, and LED backlight system. The screen format is intended to support the 16:9 FHD, 1920(H) x 1080(V) screen and 16.7M colors (RGB 8-bits data driver) with LED backlight driving circuit.

G133HAN01.0 is designed for a display unit of industrial machine.

2.1 General Specification

The following items are characteristics summary on the table at 25 °C condition:

Items	Unit	Specifications
Screen Diagonal	[inch]	13.3"
Active Area	[mm]	293.472 (H) x 165.078 (V)
Pixels H x V		1920 x 3(RGB) x 1080
Pixel Pitch	[mm]	0.15285x 0.15285
Pixel Format		R.G.B. Vertical Stripe
Display Mode		AHVA
White Luminance (Center)	[cd/m ²]	400 Typ.
Luminance Uniformity		80% (5 points, Typ.)
Contrast Ratio		800:1 (Typ.)
Response Time	[ms]	25 (Typ.)/ 35 (Max.)
Nominal Input Voltage VDD	[Volt]	+3.3 (Typ.)
LCD Power Consumption	[Watt]	1.8 W (Max. White Pattern)
LED Power Consumption	[Watt]	15W (Max.)
Weight	[Grams]	500 (Max.)
Physical Size	[mm]	309.7 x 184.1 x 9.6 (Typ.)
Electrical Interface		LVDS
Surface Treatment		Anti-glare
Support Color		16.7M Colors (RGB 8-bits)
Temperature Range		
Operating	[°C]	-20 to +70
Storage (Non-Operating)	[°C]	-20 to +70



Product Specification

AU OPTRONICS CORPORATION

2.2 Optical Characteristics

The optical characteristics are measured under stable conditions at 25°C (Room Temperature) :

Item	Unit	Conditions	Min.	Typ.	Max.	Note		
Central Luminance	cd/m ²		320	400	---	1, 3, 4		
Viewing Angle	degree	Horizontal (Right)	75	89	---	3, 7		
		Horizontal (Left)	75	89	---			
	Vertical	Vertical (Upper)	75	89	---			
		Vertical (Lower)	75	89	---			
Luminance Uniformity		5 Points	75	80	---	1, 2, 3		
Contrast Ratio			600	800	-	3, 5		
Response Time	msec	Rising + Falling	---	25	35	3, 6		
Color / Chromaticity Coordinates	Red	Rx	0.625	0.675	0.725	3		
		Ry	0.266	0.316	0.366			
	Green	Gx	0.235	0.285	0.335			
		Gy	0.605	0.655	0.705			
	Blue	Bx	0.103	0.153	0.203			
		By	0.000	0.036	0.086			
	White	Wx	0.263	0.313	0.363			
		Wy	0.279	0.329	0.379			
	NTSC	%		-	90		-	

Note 1: 5 points position (Ref: Active area)

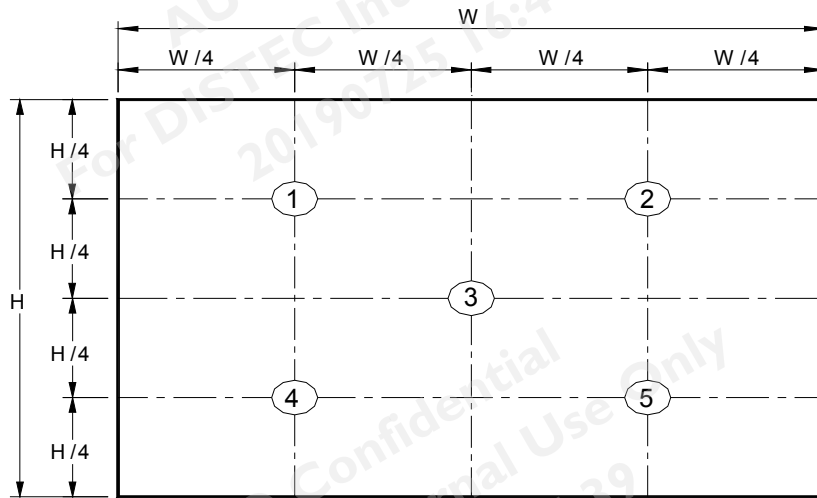

Note 2: The luminance uniformity of 5 points is defined by dividing the maximum luminance values by the minimum test point luminance

$$\delta_{w5} = \frac{\text{Maximum Brightness of five points}}{\text{Minimum Brightness of five points}}$$

Note 3: Measurement method

The LCD module should be stabilized at given temperature for 30 minutes to avoid abrupt temperature change during measuring. In order to stabilize the luminance, the measurement should be executed after lighting Backlight for 30 minutes in a stable, windless and dark room, and it should be measured in the center of screen.

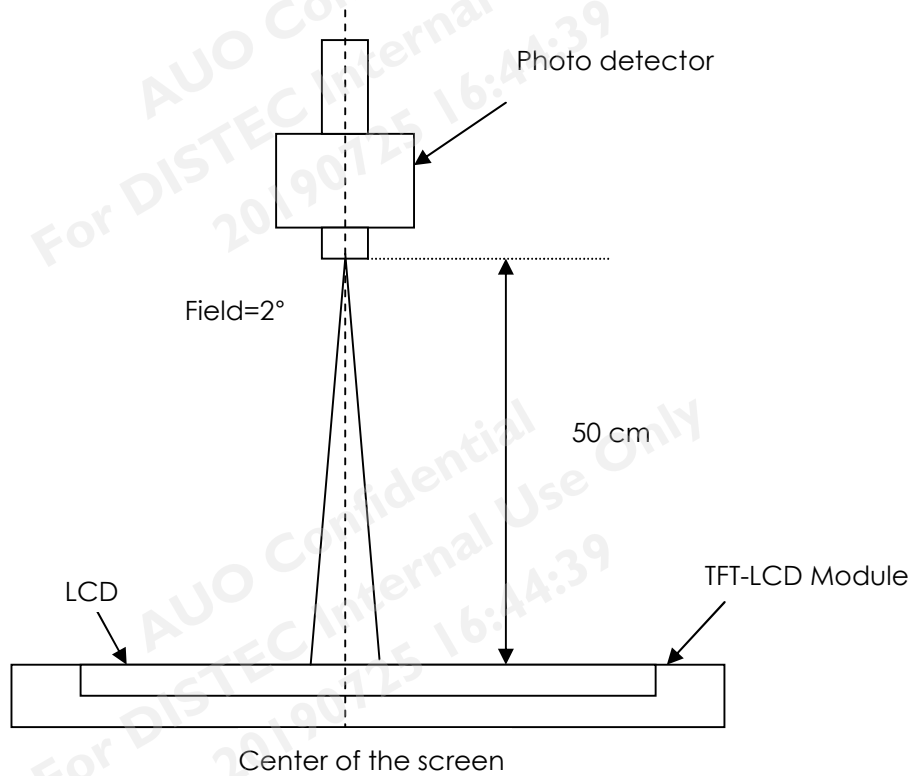

Note 4: Definition of Average Luminance of White (Y_L):

Measure the luminance of gray level 63 at 5 points , $Y_L = [L(1) + L(2) + L(3) + L(4) + L(5)] / 5$

L(x) is corresponding to the luminance of the point X at Figure in Note (1).

Note 5: Definition of contrast ratio:

Contrast ratio is calculated with the following formula.

$$\text{Contrast ratio (CR)} = \frac{\text{Brightness on the "White" state}}{\text{Brightness on the "Black" state}}$$

Note 6: Definition of response time:

The output signals of BM-7 or equivalent are measured when the input signals are changed from "Black" to "White" (falling time) and from "White" to "Black" (rising time), respectively. The response time interval is between the 10% and 90% of amplitudes. Refer to figure as below.

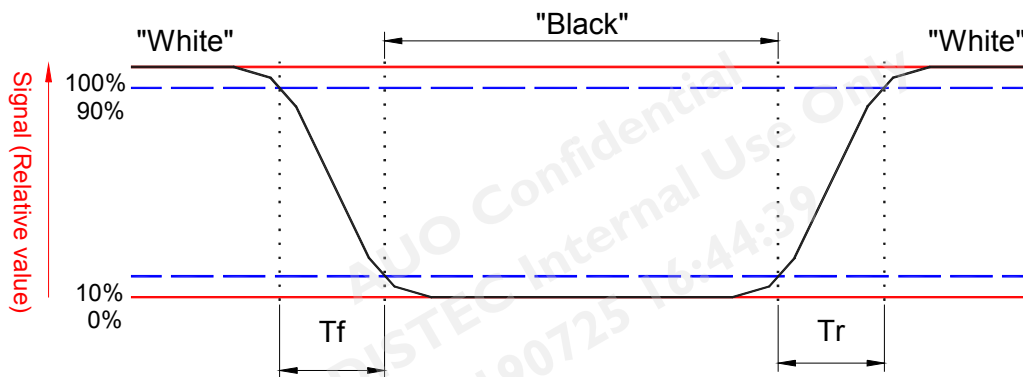

Note 7: Definition of viewing angle

Viewing angle is the measurement of contrast ratio >10, at the screen center, over a 180° horizontal and 180° vertical range (off-normal viewing angles). The 180° viewing angle range is broken down as follows; 90° (θ) horizontal left and right and 90° (Φ) vertical, high (up) and low (down). The measurement direction is typically perpendicular to the display surface with the screen rotated about its center to develop the desired measurement viewing angle.

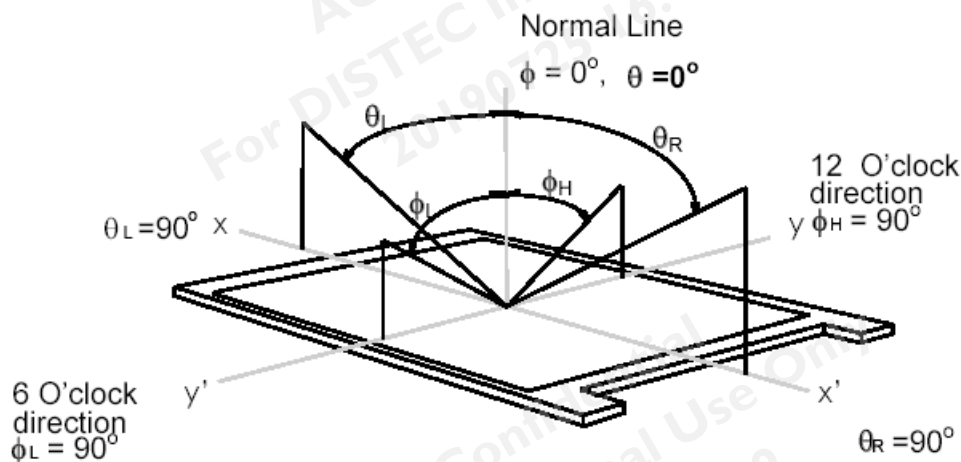

3. Functional Block Diagram

The following diagram shows the functional block of the 13.3 inch Color TFT-LCD Module:

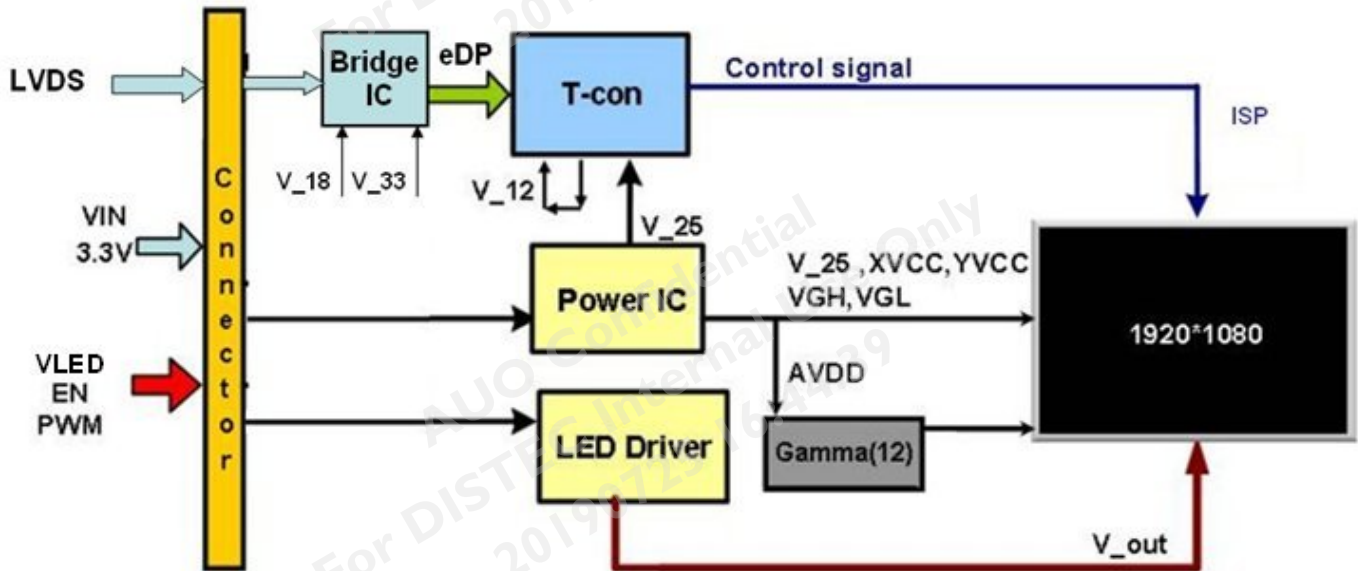



Product Specification

AU OPTRONICS CORPORATION

4. Absolute Maximum Ratings

An absolute maximum rating of the module is as following:

4.1 Absolute Ratings of TFT LCD Module

Item	Symbol	Min	Max	Unit	Conditions
Logic/LCD Drive Voltage	VDD	-0.3	+4.0	[Volt]	Note 1,2
BL Input Voltage	VLED	-0.3	+34.0	[Volt]	Note 1,2
Signal Voltage	RinI-/+ , CkIN-/+	-0.3	VDD+0.3	[Volt]	Note 1, I=0,1,2,3
Signal Voltage	LED_EN , LED_PWM	-0.3	+5.5	[Volt]	Note 1,2

4.2 Absolute Ratings of Environment

Item	Symbol	Min	Max	Unit	Conditions
Operating Temp.	TOP	-20	+70	[°C]	Note 4
Operation Humidity	HOP	8	90	[%RH]	Note 4
Storage Temperature	TST	-20	+70	[°C]	Note 4
Storage Humidity	HST	5	90	[%RH]	Note 4

Note 1: At Ta (25°C)

Note 2: Permanent damage to the device may occur if exceed maximum values

Note 3: LED specification refer to section 5.2

Note 4: For quality performance, please refer to AUO IIS (Incoming Inspection Standard)

5. Electrical Characteristics

5.1 TFT LCD Module

5.1.1 Power Specification

Input power specifications are as follows;

The power specification are measured under 25°C and frame frequency under 60Hz

Symble	Parameter	Min	Typ	Max	Units	Note
VDD	Logic/LCD Drive Voltage	3.0	3.3	3.6	[Volt]	
PDD	VDD Power	-	-	1.8	[Watt]	Note 1
IDD	IDD Current	-	-	500	[mA]	Note 1
IRush	Inrush Current	-	-	2	[A]	Note 2
VDDrp	Allowable Logic/LCD Drive Ripple Voltage	-	-	200	[mV] p-p	

Note 1: Maximum Measurement Condition : White Pattern at 3.6V driving voltage ($P_{max}=V_{3.6} \times I_{white}$)

Note 2: Measure Condition

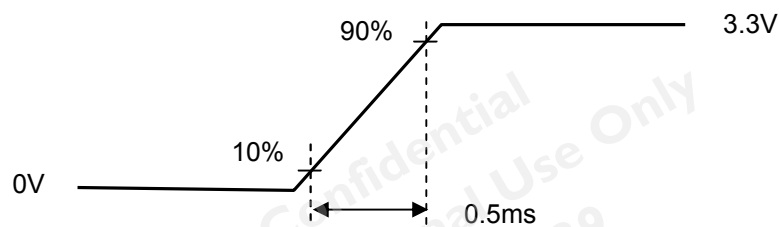
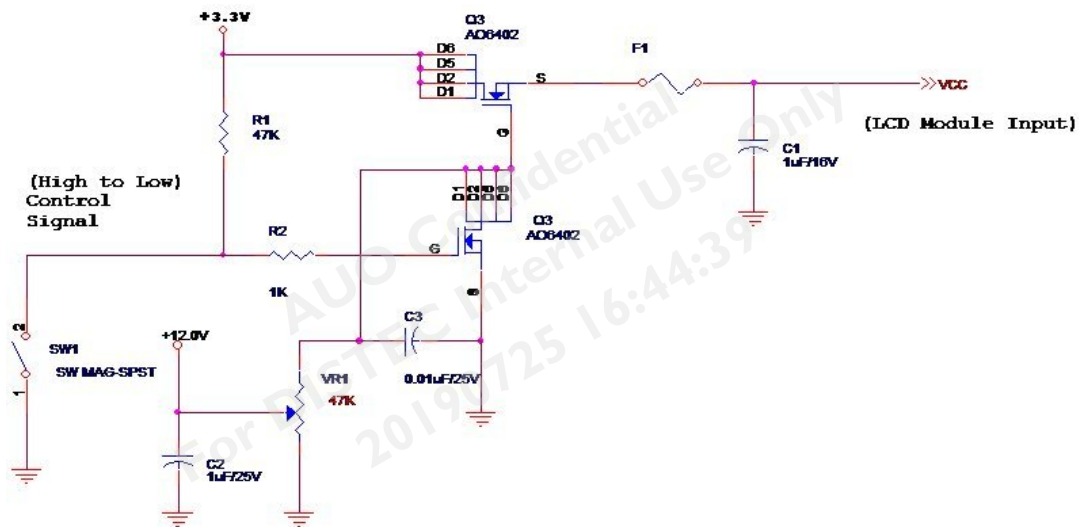

Vin rising time

5.1.2 Signal Electrical Characteristics

Input signals shall be low or High-impedance state when VDD is off.

Signal electrical characteristics are as follows;

Symbol	Parameter	Min	Typ	Max	Units	Condition
V_{TH}	Differential Input High Threshold	-	-	+100	[mV]	$V_{CM} = 1.2V$ Note 1
V_{TL}	Differential Input Low Threshold	-100	-	-	[mV]	$V_{CM} = 1.2V$ Note 1
$ V_{ID} $	Input Differential Voltage	100	400	600	[mV]	Note 1
V_{CM}	Differential Input Common Mode Voltage	+1.125	-	+1.375	[Volt]	$V_{TH} - V_{TL} = 200mV$ (max) Note 1

Note 1: LVDS Signal Waveform

•

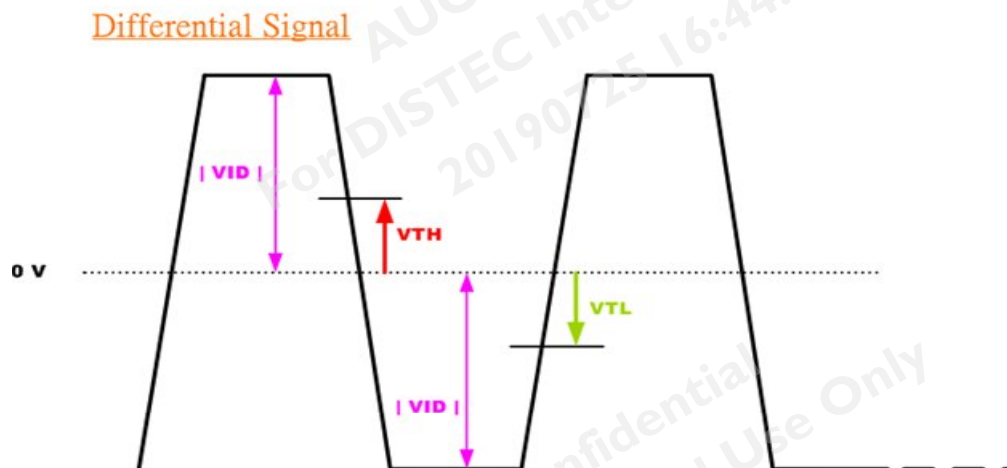
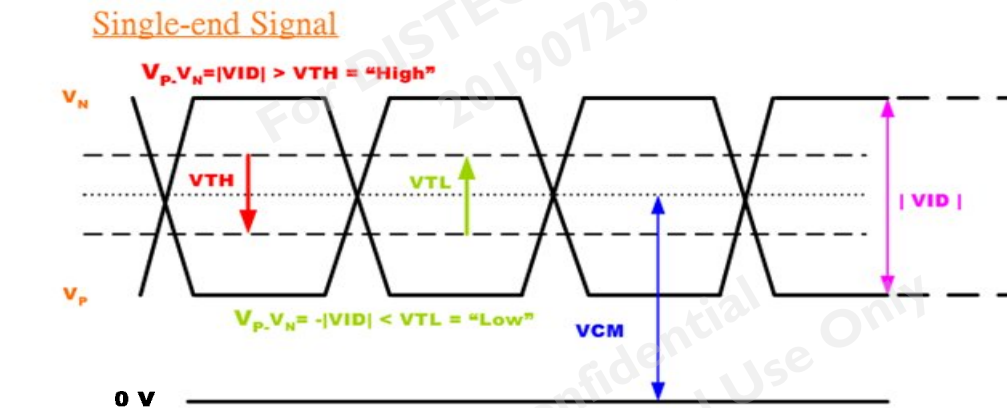



Product Specification

AU OPTRONICS CORPORATION

5.2 Backlight Unit

5.2.1 LED characteristics

Parameter	Symbol	Min	Typ	Max	Units	Condition
Backlight Power Consumption	PLED	-	-	15W	[Watt]	(Ta=25°C), Note 1
LED Life-Time	N/A	-	50,000	-	Hour	(Ta=25°C), Note 2

Note 1: Calculator value for reference $P_{LED} = V_F$ (Normal Distribution) * I_F (Normal Distribution) / Efficiency

Note 2: The LED life-time define as the estimated time to 50% degradation of initial luminous.

5.2.2 Backlight input signal characteristics

Parameter	Symbol	Min	Typ	Max	Units	Remark
LED Power Supply	VLED	10.8	12.0	13.2	[Volt]	Define as Connector Interface (Ta=25°C)
LED Input current	ILED	-	1.25	-	[A]	
LED Enable Input High Level	LED_EN	2	-	5	[Volt]	
LED Enable Input Low Level		-	-	0.8	[Volt]	
PWM Logic Input High Level	LED_PWM	2	-	5	[Volt]	
PWM Logic Input Low Level		-	-	0.52	[Volt]	
PWM Input Frequency	FPWM	500	-	10K	Hz	
PWM Duty Ratio	Duty	5	-	100	%	
LED Inrush Current	ILED _{Rush}	-	-	3	[A]	



6.2 The Input Data Format

Interface	Type	Data
LVDS	JEIDA	8 bit

JEIDA / NS Mapping Format (Using JEIDA)

RXIN1D0 N/P	J:RA6=G2	J:RA5=R7	J:RA4=R6	J:RA3=R5	J:RA2=R4	J:RA1=R3	J:RA0=R2
RXIN2D0 N/P	N:RA6=G0	N:RA5=R5	N:RA4=R4	N:RA3=R3	N:RA2=R2	N:RA1=R1	N:RA0=R0
RXIN1D1 N/P	J:RB6=B3	J:RB5=B2	J:RB4=G7	J:RB3=G6	J:RB2=G5	J:RB1=G4	J:RB0=G3
RXIN2D1 N/P	N:RB6=B1	N:RB5=B0	N:RB4=G5	N:RB3=G4	N:RB2=G3	N:RB1=G2	N:RB0=G1
RXIN1D2 N/P	J:RC6=DE	J:RC5=VS	J:RC4=HS	J:RC3=B7	J:RC2=B6	J:RC1=B5	J:RC0=B4
RXIN2D2 N/P	N:RC6=DE	N:RC5=VS	N:RC4=HS	N:RC3=B5	N:RC2=B4	N:RC1=B3	N:RC0=B2
RXIN1D3 N/P	J:RD6=X	J:RD5=B1	J:RD4=B0	J:RD3=G1	J:RD2=G0	J:RD1=R1	J:RD0=R0
RXIN2D3 N/P	N:RD6=X	N:RD5=B7	N:RD4=B6	N:RD3=G7	N:RD2=G6	N:RD1=R7	N:RD0=R6



Product Specification

AU OPTRONICS CORPORATION

6.3 Signal Description (CN1)

The module uses one LVDS receiver. LVDS is a differential signal technology for LCD interface and high speed data transfer device. The first LVDS port(RxOxxx) transmits odd pixels while the second LVDS port(RxExxx) transmits even pixels.

Pin	Signal	Description
1	RxOIN0-	Negative LVDS differential data input (Odd data)
2	RxOIN0+	Positive LVDS differential data input (Odd data)
3	RxOIN1-	Negative LVDS differential data input (Odd data)
4	RxOIN1+	Positive LVDS differential data input (Odd data)
5	RxOIN2-	Negative LVDS differential data input (Odd data, DSPTMG)
6	RxOIN2+	Positive LVDS differential data input (Odd data, DSPTMG)
7	GND	Power Ground
8	RxOCLKIN-	Negative LVDS differential clock input (Odd clock)
9	RxOCLKIN+	Positive LVDS differential clock input (Odd clock)
10	RxOIN3-	Negative LVDS differential data input (Odd data)
11	RxOIN3+	Positive LVDS differential data input (Odd data)
12	RxEIN0-	Negative LVDS differential data input (Even data)
13	RxEIN0+	Positive LVDS differential data input (Even data)
14	GND	Power Ground
15	RxEIN1-	Negative LVDS differential data input (Even data)
16	RxEIN1+	Positive LVDS differential data input (Even data)
17	GND	Power Ground
18	RxEIN2-	Negative LVDS differential data input (Even data)
19	RxEIN2+	Positive LVDS differential data input (Even data)
20	RxECLKIN-	Negative LVDS differential clock input (Even clock)
21	RxECLKIN+	Positive LVDS differential clock input (Even clock)
22	RxEIN3-	Negative LVDS differential data input (Even data)
23	RxEIN3+	Positive LVDS differential data input (Even data)
24	GND	Power Ground
25	AGBSEN	For AUO internal use
26	VDD	Power +3.3V
27	VDD	Power +3.3V
28	SCL	For AUO internal use
29	SDA	For AUO internal use
30	GND	Power Ground

6.4 Interface Timing (LVDS)

6.4.1 Timing Characteristics

Basically, interface timings should match the 1920x1080/ 60Hz manufacturing guide line timing.

Parameter	Symbol	Min.	Typ.	Max.	Unit	
Frame Rate	-	60	60	60	Hz	
Clock frequency	$1/T_{Clock}$	67	70.6	74.5	MHz	
Horizontal Section	Period	T_H	1023	1054	960+B	T_{clock}
	Active	T_{HD}	960			
	Blanking	T_{HB}	63	94	B	
Vertical Section	Period	T_V	1092	1116	1080+A	T_{line}
	Active	T_{VD}	1080			
	Blanking	T_{VB}	12	36	A	

Note1 : The above is as optimized setting

Note2 : The maximum clock frequency = $[(960 + B)*(1080+A)*60] < 74.5\text{MHz}$

Note3 : Horizontal related parameters must be constant without variation(H_Sync_Width, H_Front_Porch and H_Back_Porch must be constant on each scanline).

Note4 : On vertical blank area, H_Sync_Width and H_Total must be same as on the V_Active area.

Note5 : Vertical related parameters must be constant without variation.(V_Sync_Width, V_Front_Porch and V_Back_Porch must be constant on each video field).

Note6 : The DE timings also must be constant without variation(H/V timing requirements are as same as previous. Blank timing must also be constant).

6.4.2 Timing Diagram

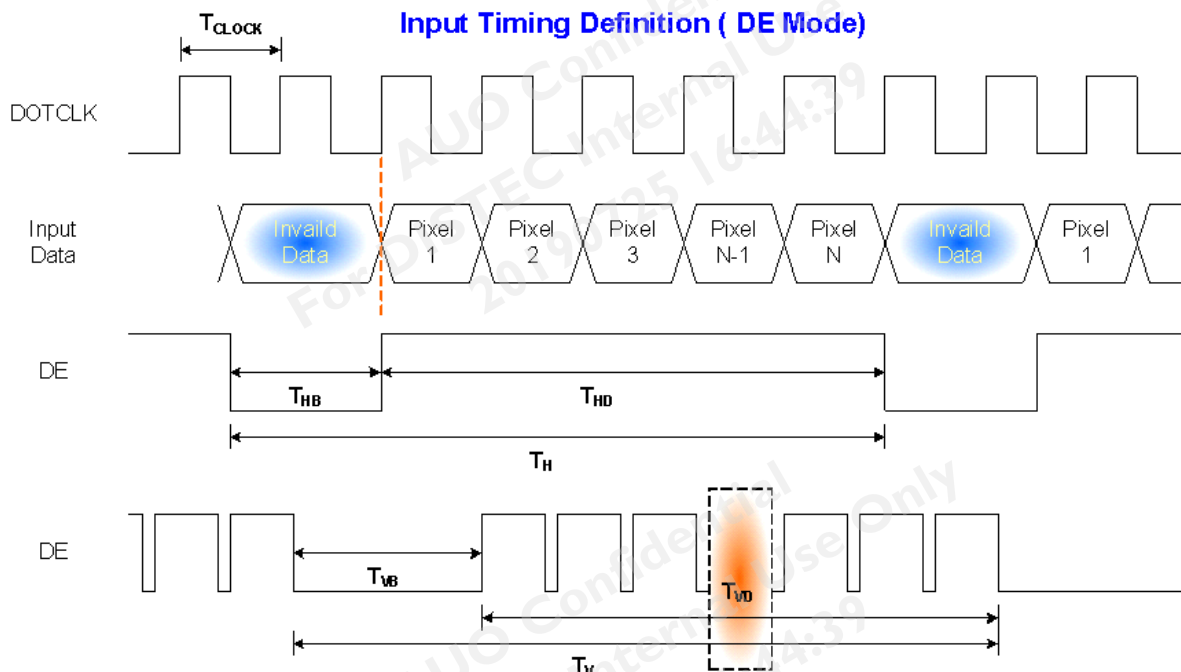

6.5 Power ON/OFF Sequence

VDD power and LED on/off sequence is as below. Interface signals are also shown in the chart. Signals from any system shall be Hi-Z state or low level when VDD is off.

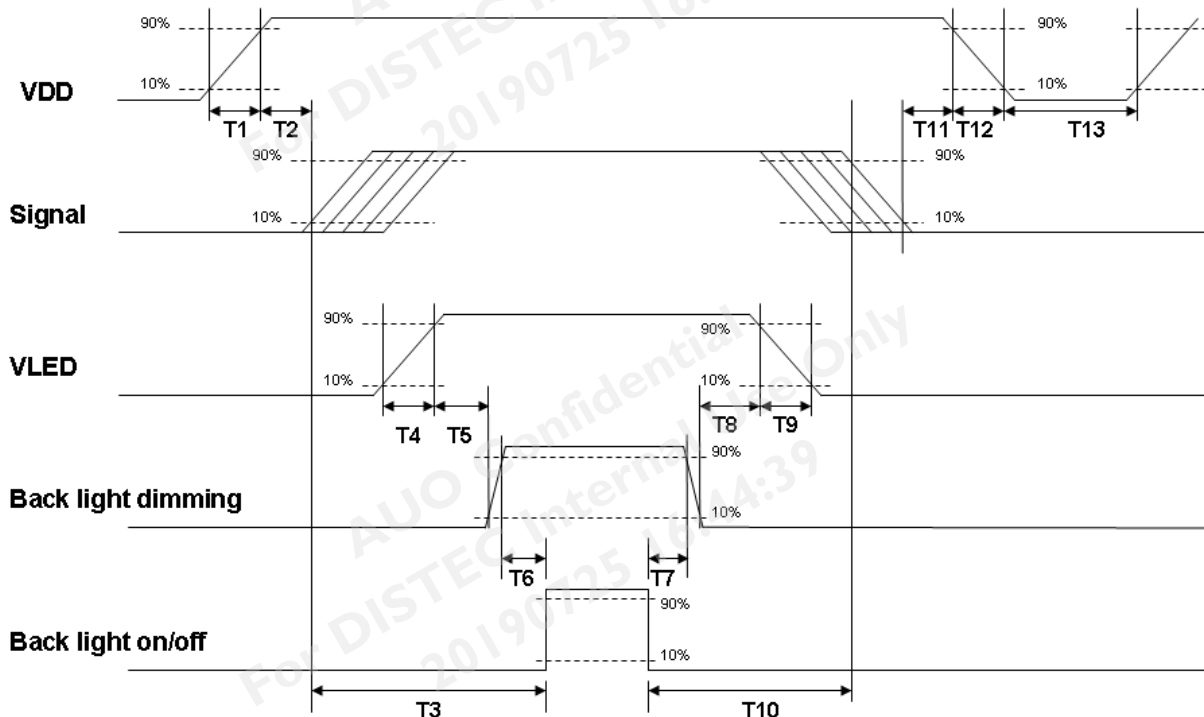

Power ON/OFF sequence timing

Parameter	Value			Units
	Min.	Typ.	Max.	
T1	0.1	-	10	[ms]
T2	200	-	-	[ms]
T3	50	-	-	[ms]
T4	0.5	-	10	[ms]
T5	10	-	-	[ms]
T6	10	-	-	[ms]
T7	10	-	-	[ms]
T8	10	-	-	[ms]
T9	0.5	-	10	[ms]
T10	50	-	-	[ms]
T11	10	-	-	[ms]
T12	-	-	10	[ms]
T13	1000	-	-	[ms]

The above on/off sequence should be applied to avoid abnormal function in the display. Please make sure to turn off the power when you plug the cable into the input connector or pull the cable out of the connector.



Product Specification

AU OPTRONICS CORPORATION

7. Connector & Pin Assignment

Physical interface is described as for the connector on module. These connectors are capable of accommodating the following signals and will be following components.

7.1 TFT LCD Module

7.1.1 Connector(CN1)

Connector Name / Designation	Interface Connector / Interface card
Manufacturer	Hirose
Type Part Number	DF19K-30P-1H (54)
Mating Housing Part Number	DF19G-30S-1C(05) DF19A-2830SCFA(41)

7.1.2 Pin Assignment(CN1)

Pin#	Signal Name	Pin#	Signal Name
1	RxOIN0-	2	RxOIN0+
3	RxOIN1-	4	RxOIN1+
5	RxOIN2-	6	RxOIN2+
7	GND	8	RxOCLKIN-
9	RxOCLKN+	10	RxOIN3-
11	RxOIN3+	12	RxEIN0-
13	RxEIN0+	14	GND
15	RxEIN1-	16	RxEIN1+
17	GND	18	RxEIN2-
19	RxEIN2+	20	RxECLKIN-
21	RxECLKIN+	22	RxEIN3-
23	RxEIN3+	24	GND
25	AGBSEN	26	VDD
27	VDD	28	SCL
29	SDA	30	GND

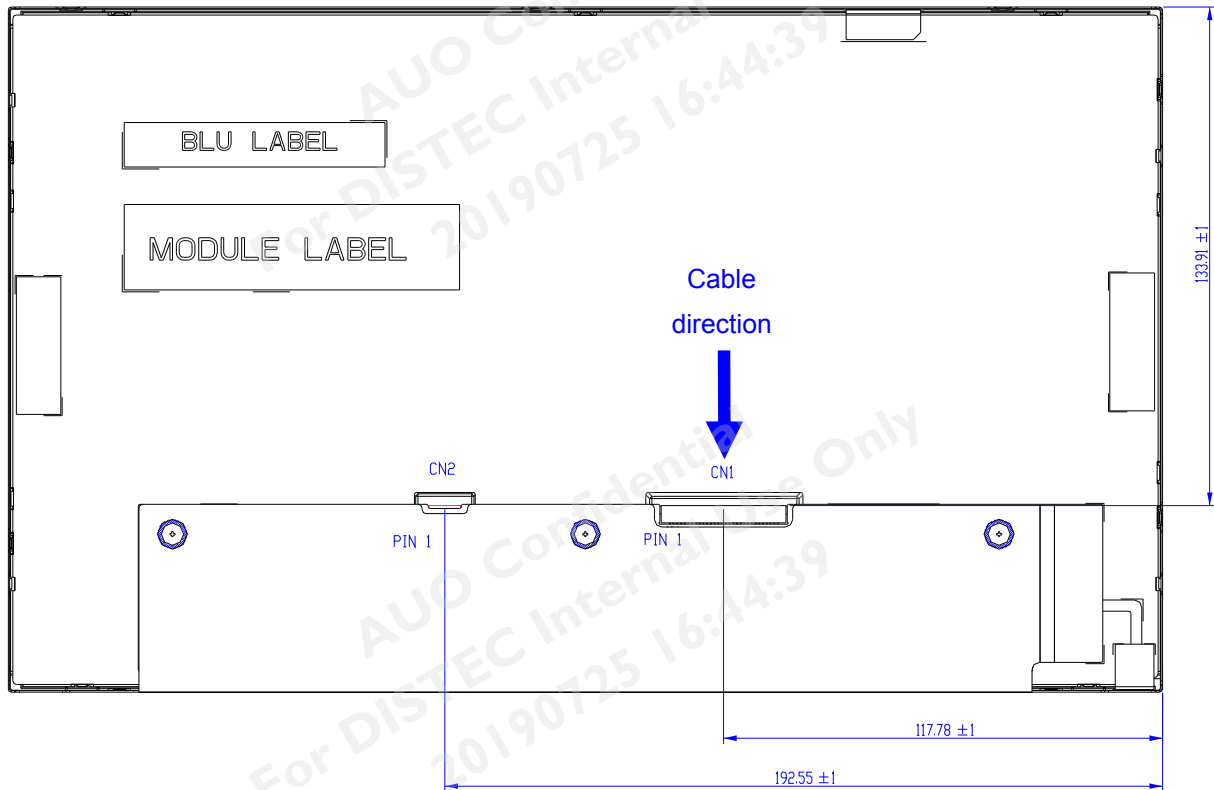

7.2 Backlight Unit

Physical interface is described as for the connector on module. These connectors are capable of accommodating the following signals and will be following components.

7.2.1 Connector (CN2)

Connector Name / Designation	LED Connector
Manufacturer	Hirose
Type Part Number	DF19G-8P-1H(54)
Mating Housing Part Number	DF19G-8S-1C(05) DF19A-2830SCFA(41)

7.2.2 LED Driver Connector Pin Assignment (CN2)

Pin#	Symbol	Signal Name
1	LED_EN	LED enable pin
2	LED_PWM	System PWM Single Input
3	NC	No connect
4	VLED	+12V
5	VLED	+12V
6	NC	No connect
7	GND	Ground
8	GND	Ground

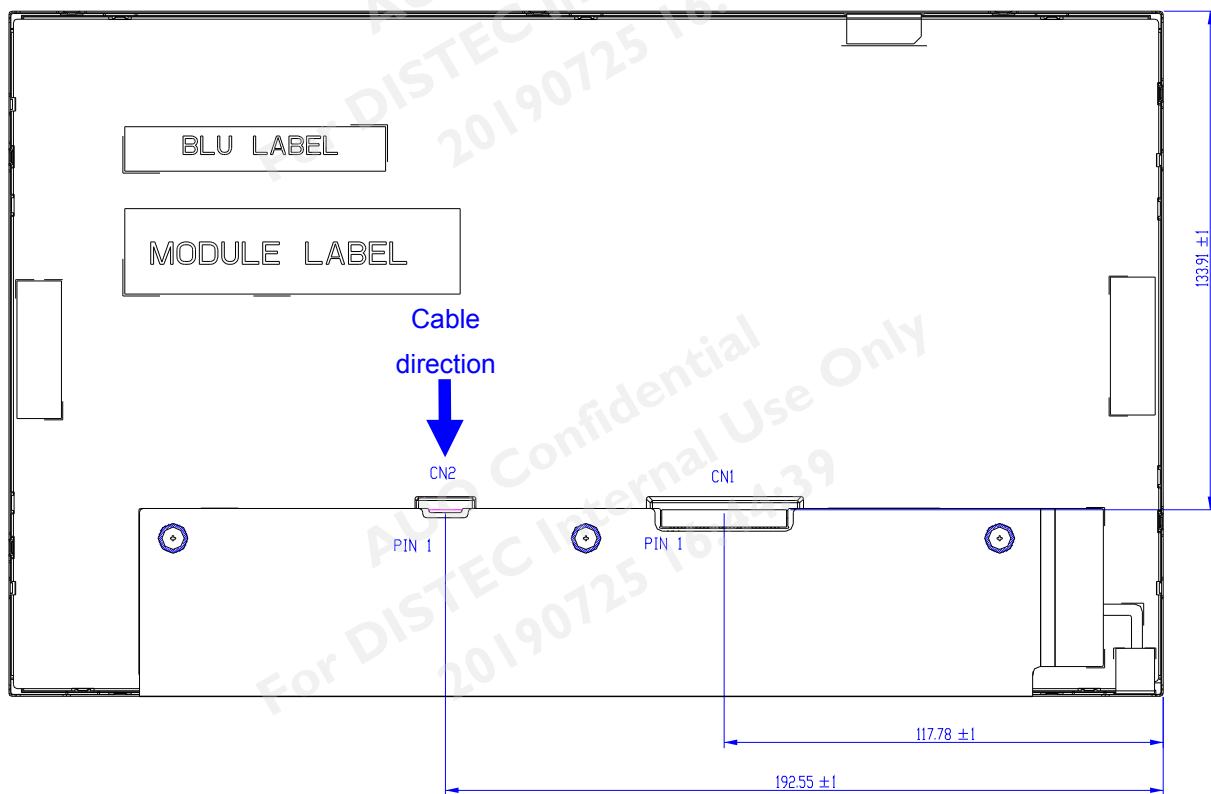



8. Panel Reliability Test

Items	Required Condition	Note
Temperature Humidity Bias	Ta= 40°C, 90%RH, 300h	Note 1,2
High Temperature Operation	Ta= 70°C , Dry, 300h	
Low Temperature Operation	Ta=-20°C, 300h	
High Temperature Storage	Ta= 70°C, Dry, 300h	
Low Temperature Storage	Ta= -20°C, 300h	
Thermal Shock Test	Ta=-20°C to 60°C, Duration at 30 min, 50 cycles	Note 1,2
Vibration test(non-operation)	1.5G, (10~200Hz~10, random), 30 mins/axis (X, Y, Z)	
Shock Test(non-operation)	50G,20ms,Half-sine wave,(±X, ±Y, ±Z)	Note 1
ESD	Contact Discharge: ±8 KV, 150pF(330Ω) 1sec, 8Points, 25times/point Air Discharge: ±15 KV, 150pF(330Ω) 1sec, 8Points, 25times/point	

Note 1: According to EN 61000-4-2 , ESD class B: Some performance degradation allowed.
 Self-recoverable. No data lost, No hardware failures.

Note 2:

- Water condensation is not allowed for each test items.
- Each test is done by new TFT-LCD module. Don't use the same TFT-LCD module repeatedly for reliability test.
- The reliability test is performed only to examine the TFT-LCD module capability.
- To inspect TFT-LCD module after reliability test, please store it at room temperature and room humidity for 24 hours at least in advance.
- No function failure occurs. Mura shall be ignored after high temperature reliability test

9. Label and Package

9.1 Shipping Label Format

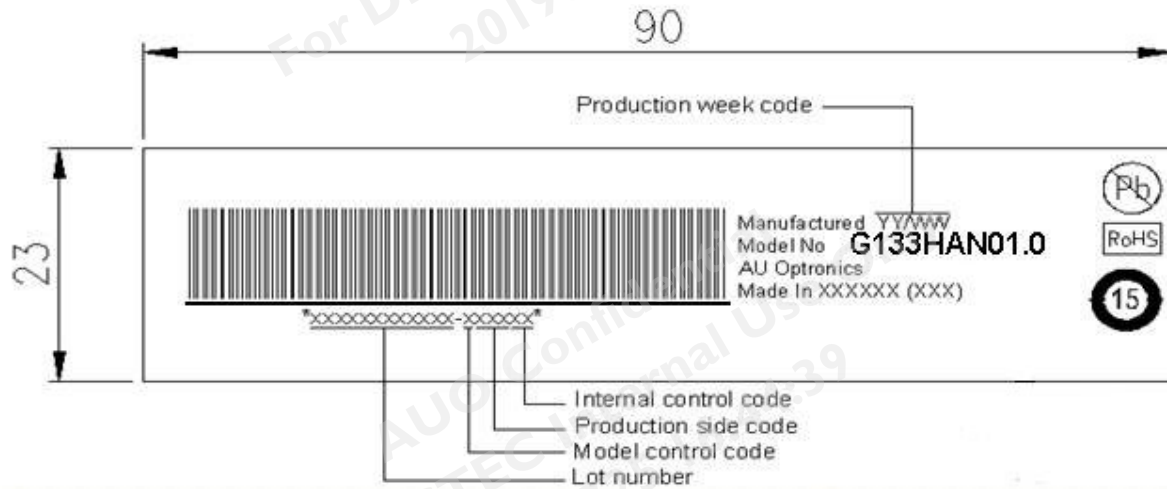

9.2 Carton Package

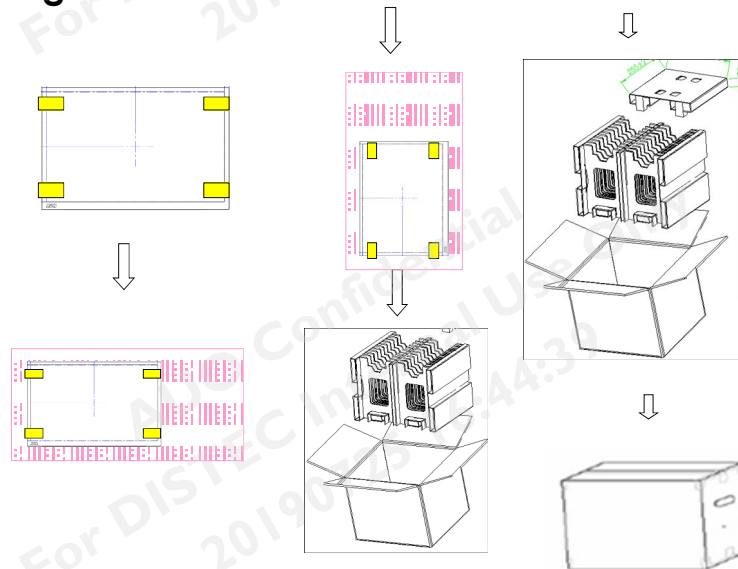

Max capacity : 20 TFT-LCD module per carton

Max weight: 10.5 kg per carton

Outside dimension of carton: 480mm(L)*275mm(W)*450mm(H)

Pallet size : 1150 mm * 910 mm * 132mm

Box stacked

Module by air : (2 *3) *3 layers , one pallet put 18 boxes , total 360pcs module

Module by sea : (2 *3) *3 layers+ one pallet (2 *3) *1 layer , total 480pcs module

Module by sea_HQ : (2 *3) *3 layers+ one pallet (2 *3) *1 layer , total 480pcs module



Product Specification

AU OPTRONICS CORPORATION

10 .Mechanical Characteristics

10.1 LCM Outline Dimension (Front View)

- NOTES:
 1. CN1: LVDS INTERFACE CONNECTOR TO BE HRS DF19K-30P-1H(54)
 2. CN2: LED DRIVER CONNECTOR TO BE HRS DF19G-8P-1H(54)
 3. USER HOLE MAXIMUM INSERTION DEPTH IS 2.5mm.
 4. UNSPECIFIED TOLERANCE TO BE ±0.5mm.

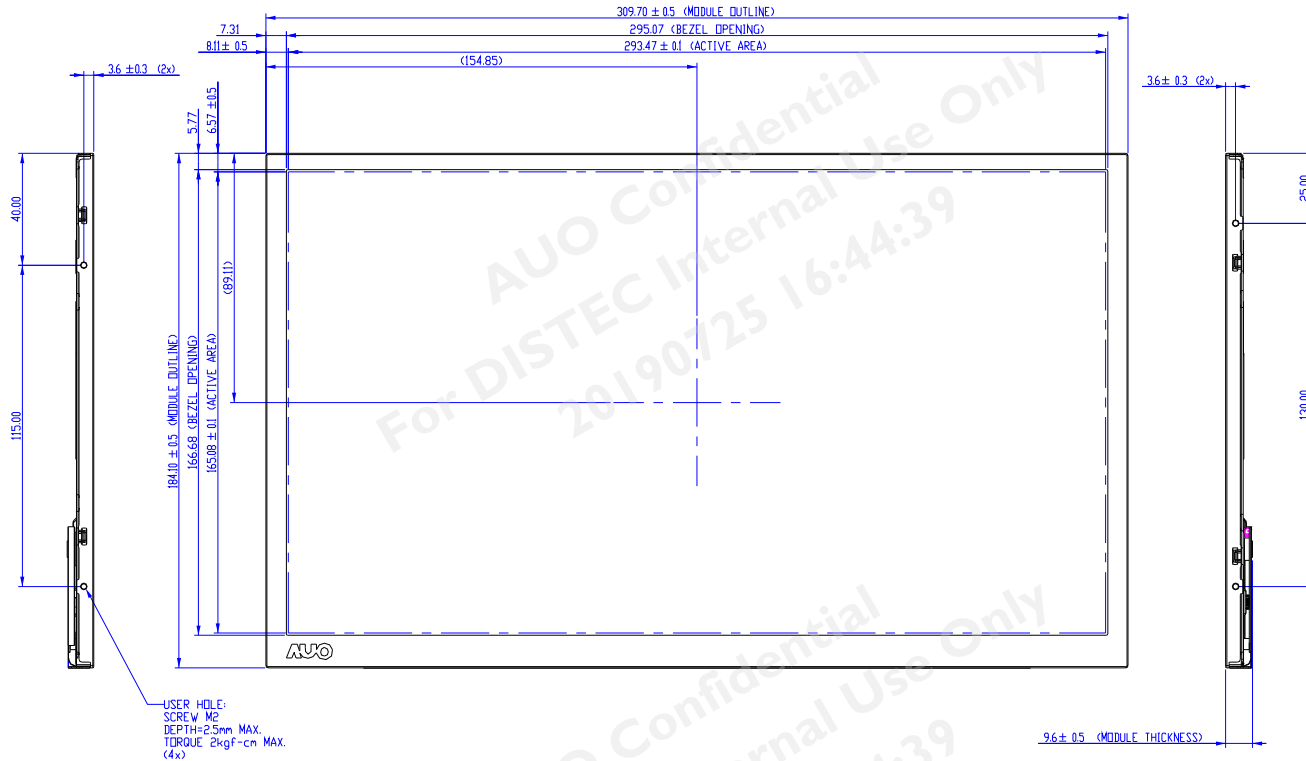

AUO Confidential
For DISTEC Internal Use Only
20190725 16:44:39



Product Specification

AU OPTRONICS CORPORATION

10.2 LCM Outline Dimension (Rear View)

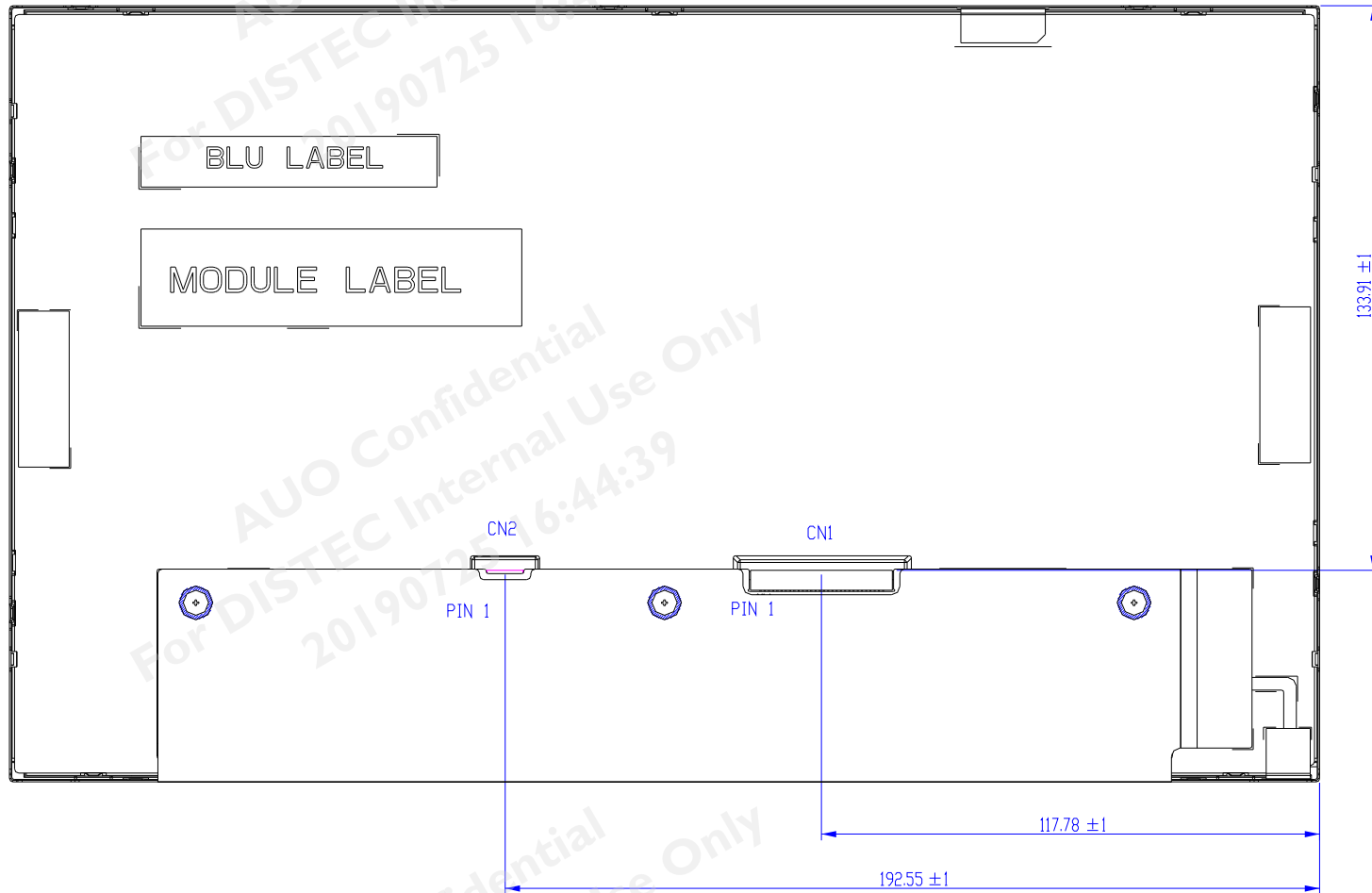

Our company network supports you worldwide with offices in Germany, Austria, Switzerland, the UK and the USA. For more information please contact:

Headquarters

Germany



FORTEC Elektronik AG

Augsburger Str. 2b
82110 Germering

Phone: +49 89 894450-0
E-Mail: info@forteca.de
Internet: www.forteca.de

Fortec Group Members

Austria



Distec GmbH Office Vienna

Nuschinggasse 12
1230 Wien

Phone: +43 1 8673492-0
E-Mail: info@distec.de
Internet: www.distec.de

Germany



Distec GmbH

Augsburger Str. 2b
82110 Germering

Phone: +49 89 894363-0
E-Mail: info@distec.de
Internet: www.distec.de

Switzerland



ALTRAC AG

Bahnhofstraße 3
5436 Würenlos

Phone: +41 44 7446111
E-Mail: info@altrac.ch
Internet: www.altrac.ch

United Kingdom



Display Technology Ltd.

Osprey House, 1 Osprey Court
Hichingbrooke Business Park
Huntingdon, Cambridgeshire, PE29 6FN

Phone: +44 1480 411600
E-Mail: info@displaytechnology.co.uk
Internet: www.displaytechnology.co.uk

USA



Apollo Display Technologies, Corp.

87 Raynor Avenue,
Unit 1 Ronkonkoma,
NY 11779

Phone: +1 631 5804360
E-Mail: info@apolloDisplays.com
Internet: www.apolloDisplays.com