



OUR GLOBAL
COMPETENCE
CENTRES

 APOLLO DISPLAY
TECHNOLOGIES



 DISTEC



 DISPLAY
TECHNOLOGY



Datasheet

Distec

DD-0840-XE01

DD-01-001

PRODUCT SPECIFICATIONS(Preliminary)

For Customer: _____

: APPROVAL FOR SPECIFICATION

Customer Model No. _____

: APPROVAL FOR SAMPLE

Module No.: **DD-0840-XE01**

Date : 2020.08.05

Table of Contents

| No. | Item | Page |
|-----|-------------------------------------|------|
| 1 | Table of Contents | P3 |
| 2 | Revision Record | P4 |
| 3 | General Specifications | P5 |
| 4 | Outline Drawing | P6 |
| 5 | Absolute Maximum Ratings | P7 |
| 6 | Electrical Specifications | P9 |
| 7 | Optical Characteristics | P17 |
| 8 | Reliability Test Items and Criteria | P21 |
| 9 | Precautions for Use of LCD Modules | P22 |
| | | |
| | | |
| | | |

For Customer's Acceptance:

| Approved By | Comment |
|-------------|---------|
| | |

| PREPARED | CHECKED | VERIFIED BY QA DEPT | VERIFIED BY R&D DEPT |
|----------|---------|---------------------|----------------------|
| LC | | | |

2. Revision Record

| Date | Rev.No. | Page | Revision Items | Prepared |
|------------|---------|------|--|----------|
| 2020.07.10 | V0 | | The first release | LC |
| 2020.07.23 | V1 | | Updated Luminance in Item6,Item#7 and Item#8 | CJ |
| 2020.08.01 | V2 | | Updated Item3,Item#6.3.1,6.3.2 and Item#8 | CJ |
| 2020.08.05 | V3 | | Updated the Surface treatment in Item#3 | CJ |
| | | | | |
| | | | | |
| | | | | |
| | | | | |
| | | | | |
| | | | | |
| | | | | |
| | | | | |
| | | | | |
| | | | | |
| | | | | |
| | | | | |
| | | | | |
| | | | | |
| | | | | |
| | | | | |
| | | | | |

3. General Specifications

DD-0840-XE01 is an 8.4" color TFT-LCD (Thin Film Transistor Liquid Crystal Display) module composed of LCD panel, driver ICs, control circuit, LED driver and backlight unit. The 8.4" display area contains 1024 x (RGB) x 768 pixels and can display up to 16.7M colors.

This product is RoHS compliant.

| Item | Contents | Unit | Note |
|-----------------------|--------------------------------|---------|------|
| LCD Type | TFT | - | |
| Display color | 16.7M | | 1 |
| Viewing Direction | ALL | O'Clock | |
| Operating temperature | -30~+80 | °C | |
| Storage temperature | -30~+80 | °C | |
| Module size | 199.50X149.00X9.7 | mm | 2 |
| Active Area(W×H) | 170.496X127.872 | mm | |
| Number of Dots | 1024 X 768 | dots | |
| Power Supply Voltage | 3.3 | V | |
| TFT Controller | HX8290-A-LT*2+HX8695-E-LT | | |
| Weight | --- | g | |
| Interface | LVDS | - | |
| Surface treatment | Anti-Glare and hard-coating 3H | | |

Note 1: Color tune is slightly changed by temperature and driving voltage.

Note 2: Without FPC and Solder.

4. Outline Drawing

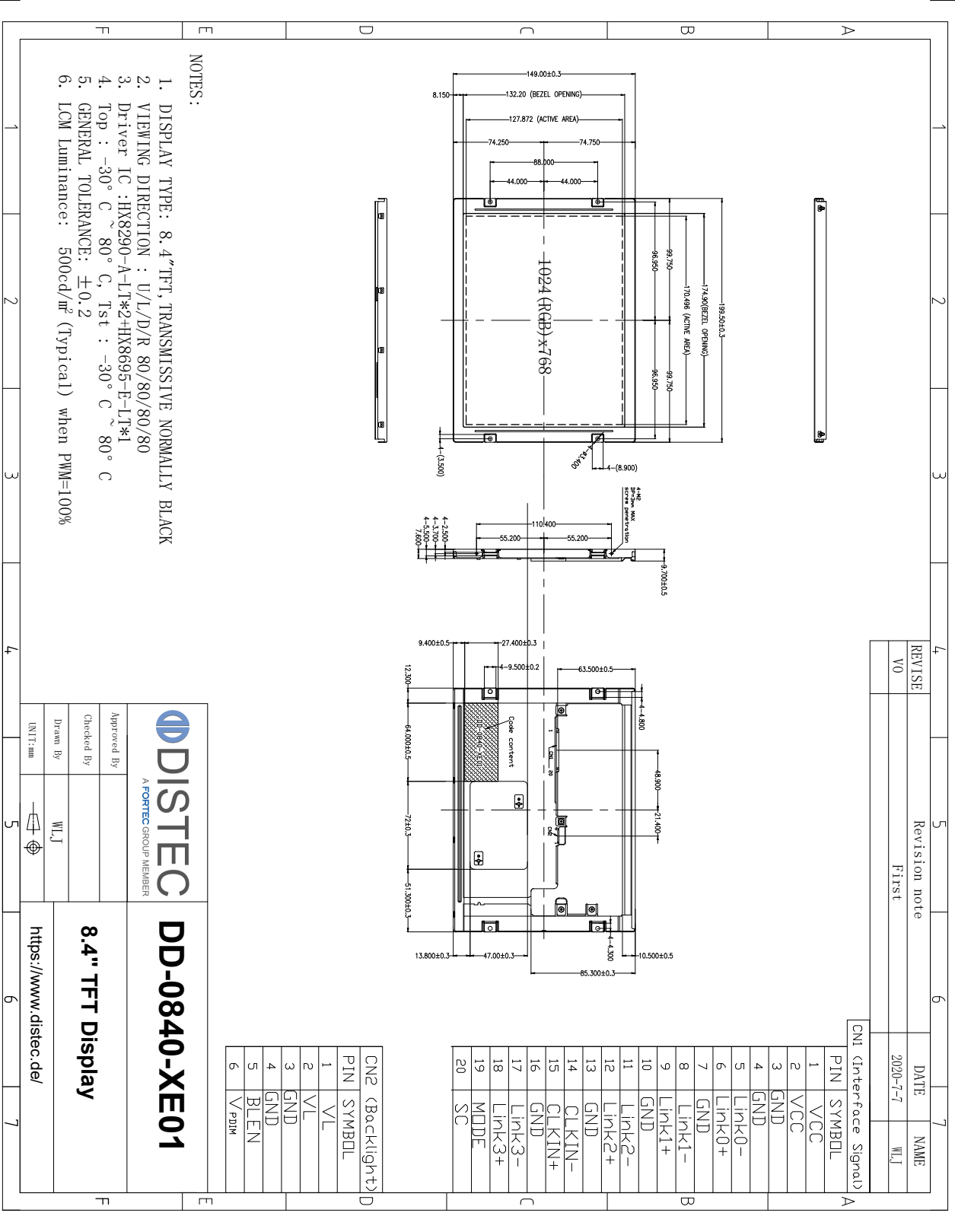

- NOTES:
1. DISPLAY TYPE: 8.4" TFT, TRANSMISSIVE NORMALLY BLACK
 2. VIEWING DIRECTION : U/L/D/R 80/80/80/80
 3. Driver IC : HX8290-A-LT*2+HX8695-E-LT*1
 4. Top : -30° C ~ 80° C, Tst : -30° C ~ 80° C
 5. GENERAL TOLERANCE: ±0.2
 6. LCM Luminance: 500cd/m² (Typical) when PWM=100%

| REVISE | Revision note | DATE | NAME |
|--------|---------------|----------|------|
| V0 | First | 2020-7-7 | WJ |

| | | | |
|-------------|------------|----------|----------|
| Approved By | Checked By | Drawn By | UNIT: mm |
| | | WJ | |

8.4" TFT Display

<https://www.distec.de/>

DISTEC
A FORTEC GROUP MEMBER
DD-0840-XE01

5. Absolute Maximum Ratings($T_a=25\text{ }^\circ\text{C}$)

5.1 Electrical Absolute Maximum Ratings.($V_{ss}=0V, T_a=25\text{ }^\circ\text{C}$)

| Item | Symbol | Min. | Max. | Unit | Note |
|----------------------|--------|------|------|------|------|
| Power Supply Voltage | VCC | -0.3 | 4.0 | V | 1, 2 |
| | VL | -0.3 | 14.0 | V | 1, 2 |
| | VPDIM | -0.3 | 14.0 | V | 1, 2 |
| | BLEN | -0.3 | 14.0 | V | 1, 2 |

Notes:

1. If the module is used above these absolute maximum ratings, it may become permanently damaged. Using the module out of the indicated electrical range may cause malfunction and poor reliability.
2. $V_{CC} > V_{SS}$ must be maintained.
3. Please make sure users are grounded when handing LCD Module.

5.2 Environmental Absolute Maximum Ratings.

| Item | Storage | | Operating | | Note |
|---------------------|----------------------|---------------------|----------------------|---------------------|------|
| | MIN. | MAX. | MIN. | MAX. | |
| Ambient Temperature | -30 $^\circ\text{C}$ | 80 $^\circ\text{C}$ | -30 $^\circ\text{C}$ | 80 $^\circ\text{C}$ | 1,2 |
| Humidity | - | - | - | - | 3 |

1. The response time will become lower when operated at low temperature.
2. Background color changes slightly depending on ambient temperature.
The phenomenon is reversible.
3. $T_a \leq 40\text{ }^\circ\text{C}$:85%RH MAX.
 $T_a > 40\text{ }^\circ\text{C}$:Absolute humidity must be lower than the humidity of 85%RH at 40 $^\circ\text{C}$.

6. Electrical Specifications

6.1 Electrical characteristics for LCD($V_{SS}=0V, T_a=25^\circ C$)

| Parameter | Symbol | Condition | Min | Typ | Max | Unit | Note | |
|-------------------------|--------|-----------------|---------|--------|------|--------|------|--|
| Power supply | VCC | Ta=25°C | 3.0 | 3.3 | 3.6 | V | | |
| Backlight Power supply | VL | Ta=25°C | 9 | 12.0 | 13.2 | V | | |
| Input voltage | 'H' | V _{IH} | Ta=25°C | 0.7VCC | - | VCC | V | |
| | 'L' | V _{IL} | Ta=25°C | -0.3 | - | 0.3VCC | V | |
| Current of power supply | ICC | Ta=25°C | - | 180 | - | mA | | |

6.2 LED backlight specification($V_{SS}=0V, T_a=25^\circ C$)

| Item | Symbol | Min | Typ | Max | Unit | Note | |
|-----------------------|-------------------|-------------------|------|------|-------|----------------------|--|
| Supply voltage | VL | 9 | 12.0 | 13.2 | V | | |
| Supply Current | IL | - | 350 | - | mA | (VL=12V) PWM=100% | |
| Power Consumption | PL | - | 4.2 | - | W | (VL=12V) PWM=100% | |
| PWM Control Frequency | F _{PDIM} | 100 | - | 30K | Hz | | |
| Backlight ON-OFF | High | BLEN | 1.6 | - | VL | V | |
| | Low | | 0 | - | 0.8 | V | |
| PWM Control Level | High | V _{PDIM} | 1.6 | - | VL | V | |
| | Low | | 0 | - | 0.8 | V | |
| Uniformity | Δ Bp | 75 | 80 | - | % | | |
| Life Time | time | - | 50K | - | hours | 1 | |

Note 1: Brightness to be decreased to 50% of the initial value at ambient temperature $T_A=25^\circ C$

6.3 Interface signals

6.3.1 CN 1(Interface Signal)

Used connector: 20186-020E-11F (I-PEX) or FI-SEB20P-HFE (JAE)

Corresponding connector: 20197- 20U-F (I-PEX) or FI-S20S[for discrete Wire],
FI-SE20ME[for FPC] (JAE)

| Pin No. | Symbol | I/O | Function | |
|---------|--------|-----|---|------------|
| 1-2 | VCC | P | Power supply | |
| 3-4 | GND | P | Ground. | |
| 5 | LINK0- | I | LVDS lane0 input | |
| 6 | LINK0+ | I | | |
| 7 | GND | P | Ground. | |
| 8 | LINK1- | I | LVDS lane1 input | |
| 9 | LINK1+ | I | | |
| 10 | GND | P | Ground. | |
| 11 | LINK2- | I | LVDS lane2 input | |
| 12 | LINK2+ | I | | |
| 13 | GND | P | Ground. | |
| 14 | CLKIN- | I | LVDS CLK input | |
| 15 | CLKIN+ | I | | |
| 16 | GND | P | Ground. | |
| 17 | LINK3- | I | LVDS lane3 input | |
| 18 | LINK3+ | I | | |
| 19 | MODE | I | MODE=1 | LVDS 8 BIT |
| | | | MODE=0 | LVDS 6 BIT |
| 20 | SC | I | Scan direction control (Low=Normal, High=Reverse) | |

6.3.1 CN 2(Backlight)**Backlight-side connector: FI-S6P-HFE (JAE)****Corresponding connector: FI-S6S (JAE)**

| Pin No. | Symbol | I/O | Function |
|---------|--------|-----|----------------------------|
| 1-2 | VL | P | Power supply For BL. |
| 3-4 | GND | P | Ground. |
| 5 | BLEN | I | LED driver enable input |
| 6 | VPDIM | I | PWM dimming control input. |

6.4 AC Characteristics

6.4.1 For the digital circuit: LVDS mode

| Parameter | Symbol | Condition | Spec. | | | Unit |
|---|--------------|---------------|-------|------|------------------|---------|
| | | | Min. | Typ. | Max. | |
| Differential input high Threshold voltage | V_{th} | $V_{cm}=1.2V$ | - | - | +0.1 | V |
| Differential input low threshold voltage | V_{tl} | - | -0.1 | - | - | V |
| Differential input common Mode voltage | V_{CM} | - | 1 | 1.2 | $1.7- V_{id} /2$ | V |
| LVDS input voltage | V_{INLV} | - | 0.7 | - | 1.7 | V |
| Differential input voltage | $ V_{id} $ | - | 0.1 | - | 0.6 | V |
| Differential input leakage Current | I_{lvleak} | - | -10 | - | +10 | μA |

Single-ended:
 LVCLKP(R),
 LVCLKN(R),
 LVD [3:0]P(R),
 LVD [3:0]N(R)

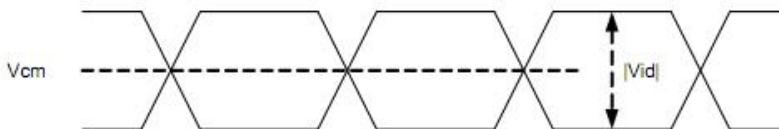

Differential:
 LVCLKP(R)-LVCLKN(R),
 LVD [3:0]P(R)-
 LVD [3:0]N(R)

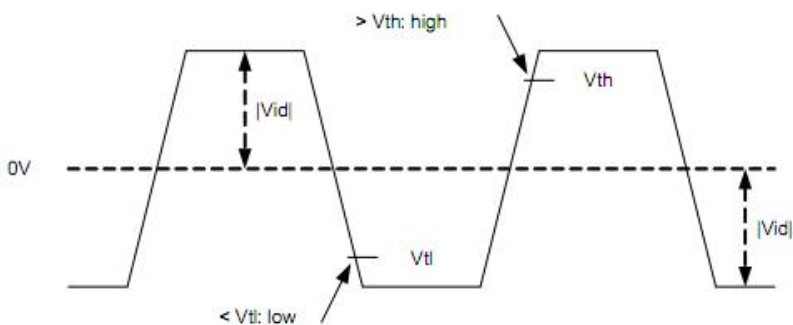

6.4.2 For the analog circuit: Normal mode

| Parameter | Symbol | Conditions | Spec. | | | Unit |
|--|--------|---|-------|------|-------|------|
| | | | Min. | Typ. | Max. | |
| Analog positive supply voltage | VSP | VSP is generated by PFM, VSPS [4:0]=14h, with proper settings and components. | 6.7 | 7 | 7.3 | V |
| Analog negative supply voltage | VSN | VSN is generated by PFM, VSNS [4:0]=14h, with proper settings and components. | -7.3 | -7 | -6.7 | V |
| Source driver positive supply voltage | VSDP | VSDP ≥ 7V, VSDPS[4:0]=14h, loading current=0 | 6.65 | 6.8 | 6.95 | V |
| Source driver negative supply voltage | VSDN | VSDN = -7V, VSDNS[4:0]=14h, loading current=0 | -6.95 | -6.8 | -6.65 | V |
| Output for positive gamma reference high voltage | VGMPHO | VSDP ≥ 6.8V, VGMPHS[4:0]=0x1Ah | 6.48 | 6.6 | 6.72 | V |
| Output for positive gamma reference voltage | VGMPMO | VSDP ≥ 6.8V, VGMPHS[4:0]=0x1Ah, VGMPLS[3:0]=0x00h | 3.3 | 3.4 | 3.5 | V |

| | | | | | | |
|--|-------------------|---|----------|-------|----------|---|
| Output for positive gamma reference low voltage | VGMPLO | VGMPLS[3:0]=0x00h | 0.12 | 0.2 | 0.28 | V |
| Output for negative gamma reference high voltage | VGMNHO | VSDN ≤ -6.8V, VGMNHS[4:0]=0x1Ah | -6.72 | -6.6 | -6.48 | V |
| Output for negative gamma reference voltage | VGMNMO | VSDN ≤ -6.8V, VGMNHS[4:0]=0x1Ah, VGMNLS[4:0]=0x00h | -3.5 | -3.4 | -3.3 | V |
| Output for negative gamma reference low voltage | VGMNLO | VGMNLS[4:0]=0x00h | -0.28 | -0.2 | -0.12 | V |
| VCOM voltage | VCOM | VCOMS[7:0]=0x80h | -1.53 | -1.48 | -1.43 | V |
| Source output voltage, positive polarity | V _{SDOP} | - | 0.2 | - | VSDP-0.2 | V |
| Source output voltage, negative polarity | V _{SDON} | - | VSDN+0.2 | - | -0.2 | V |
| Positive power supply | VGH | VGH is generated by charge pump, VGHS[3:0]=0x05h, loading current=0 | 14.6 | 15.6 | 16.6 | V |
| Negative power supply | VGL | VGL is generated by charge pump, VGLS[2:0]=0x02h, loading current=0 | -11 | -10 | -9 | V |

| Parameter | Symbol | Conditions | Spec. | | | Unit |
|---------------------------------|--------------|--|-------|------|------|---------|
| | | | Min. | Typ. | Max. | |
| Source output voltage deviation | V_{OD} | $V_{SDOP}=0.5V$ to $V_{SDP}-0.5V$, $V_{SDON}=V_{SDN}+0.5V$ to $-0.5V$ | - | - | 10 | mV |
| | | $V_{SDOP}=0.2V$ to $0.5V$ or $V_{SDOP}=V_{SDP}-0.5V$ to $V_{SDP}-0.2V$, $V_{SDON}=V_{SDN}+0.2V$ to $V_{SDN}+0.5V$ or $V_{SDON}=-0.5V$ to $-0.2V$ | - | - | 15 | mV |
| Standby current (VCC1 + VCC2) | I_{STBVCC} | "STBYB=0" and all inputs are default. | - | - | 100 | μA |
| Standby current (VSN or VSP) | I_{STB} | "STBYB=0", VSP or VSN external input | - | - | 100 | μA |

6.4.3 LVDS mode AC electrical characteristics

| Parameter | Symbol | Spec. | | | Unit |
|-------------------|--------------|-------|------|------|--------------|
| | | Min. | Typ. | Max. | |
| Clock frequency | F_{LVCCYC} | 20 | - | 85 | MHz |
| Clock period | T_{LVCCYC} | 11.76 | - | - | ns |
| 1 data bit time | UI | - | 1/7 | - | T_{LVCCYC} |
| Clock high time | T_{LVCH} | 2.8 | 4 | 4.2 | UI |
| Clock low time | T_{LVCL} | 2.8 | 3 | 4.2 | UI |
| Position 1 | T_{POS1} | -0.2 | 0 | 0.2 | UI |
| Position 0 | T_{POS0} | 0.8 | 1 | 1.2 | UI |
| Position 6 | T_{POS6} | 1.8 | 2 | 2.2 | UI |
| Position 5 | T_{POS5} | 2.8 | 3 | 3.2 | UI |
| Position 4 | T_{POS4} | 3.8 | 4 | 4.2 | UI |
| Position 3 | T_{POS3} | 4.8 | 5 | 5.2 | UI |
| Position 2 | T_{POS2} | 5.8 | 6 | 6.2 | UI |
| Input eye width | T_{EYEW} | 0.6 | - | - | UI |
| Input eye border | T_{EX} | - | - | 0.2 | UI |
| LVDS wake up time | T_{ENLVDS} | - | - | 150 | us |

LVDS with SSC

| Parameter | Symbol | Condition | Spec. | | | Unit |
|----------------------|-------------------|--|-------|------|-----|------|
| | | | Min. | Typ. | Max | |
| Modulation Frequency | SSC _{MF} | LVDS clock frequency center at 80MHz | - | - | 200 | KHz |
| | | LVDS clock frequency center at 60MHz | - | - | 150 | KHz |
| | | LVDS clock frequency center at 40MHz | - | - | 100 | KHz |
| | | LVDS clock frequency center at 20MHz | - | - | 50 | KHz |
| Modulation Rate | SSC _{MR} | LVDS clock frequency + SSCMR in the range of 20MHz~85MHz | - | - | ±5 | % |

6.4.4 TTL mode AC electrical characteristics

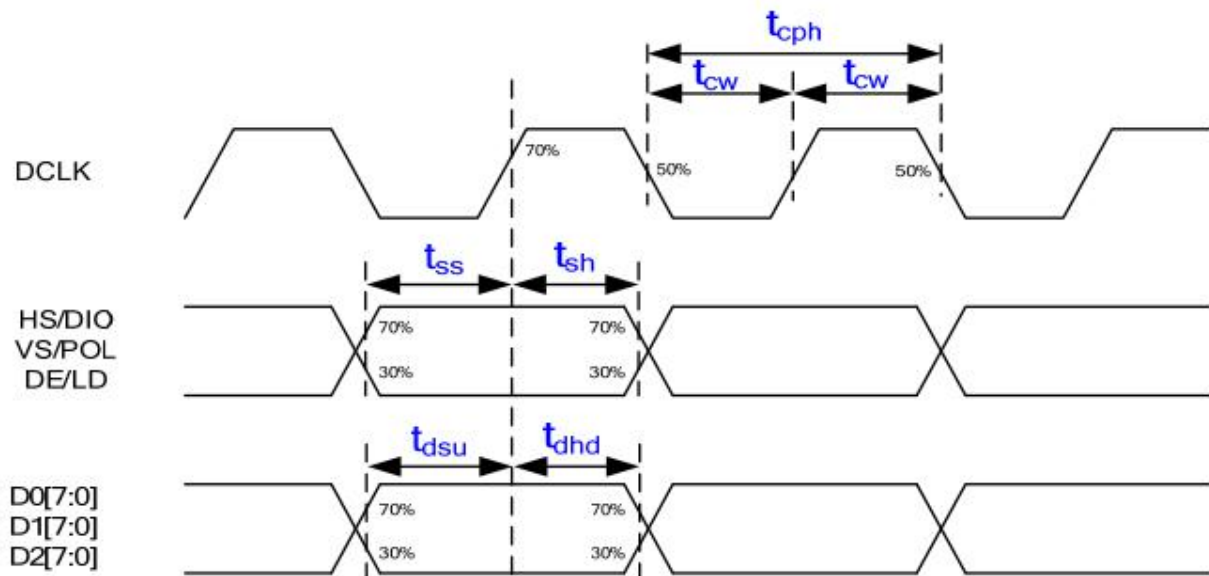

| Parameter | Symbol | Spec. | | | Unit |
|-------------------|-----------|-------|------|------|------|
| | | Min. | Typ. | Max. | |
| DCLK period | T_{cph} | 16.67 | - | - | ns |
| DCLK duty ratio | T_{cw} | 40 | 50 | 60 | % |
| Data setup time | T_{dsu} | 5 | - | - | ns |
| Data hold time | T_{dhd} | 5 | - | - | ns |
| VS/POL setup time | T_{ss} | 5 | - | - | ns |
| VS/POL hold time | T_{sh} | 5 | - | - | ns |
| HS/DIO setup time | T_{ss} | 5 | - | - | ns |
| HS/DIO hold time | T_{sh} | 5 | - | - | ns |
| DE/LD setup time | T_{ss} | 5 | - | - | ns |
| DE/LD hold time | T_{sh} | 5 | - | - | ns |

6.5 Reset timing

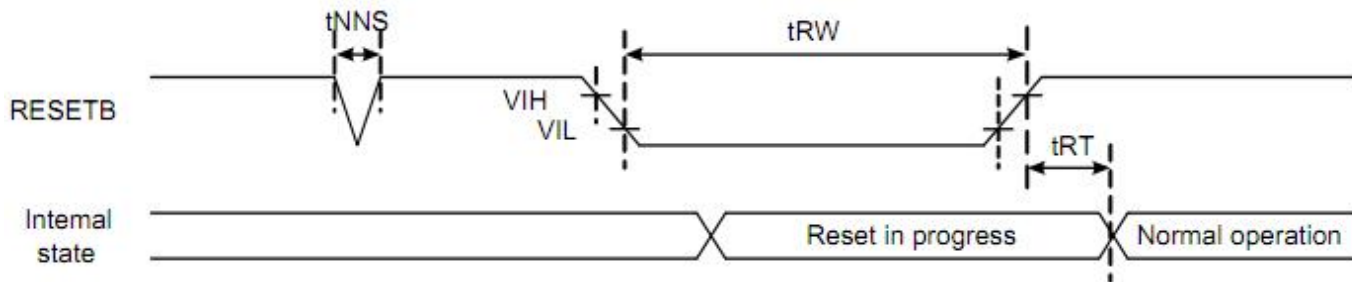

| Signal | Parameter | Symbol | Spec. | | | Unit |
|--------|----------------------------|--------|-------|------|------|------|
| | | | Min. | Typ. | Max. | |
| RESETB | Reset pulse width | tRW | 10 | - | - | μs |
| | Reset complete time | tRT | - | - | 5 | μs |
| | Negative spike noise width | tNNS | - | - | 100 | ns |

6.6 LVDS interface data format

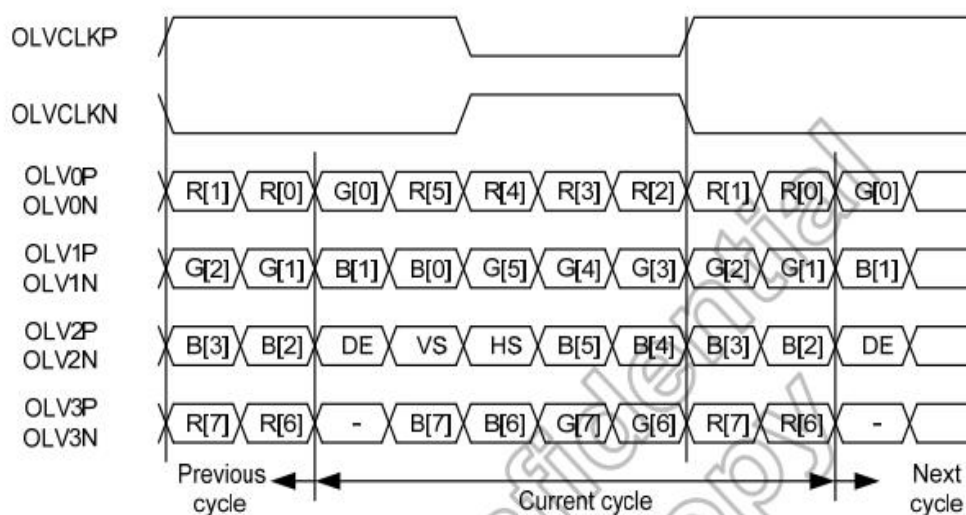

8bit mode

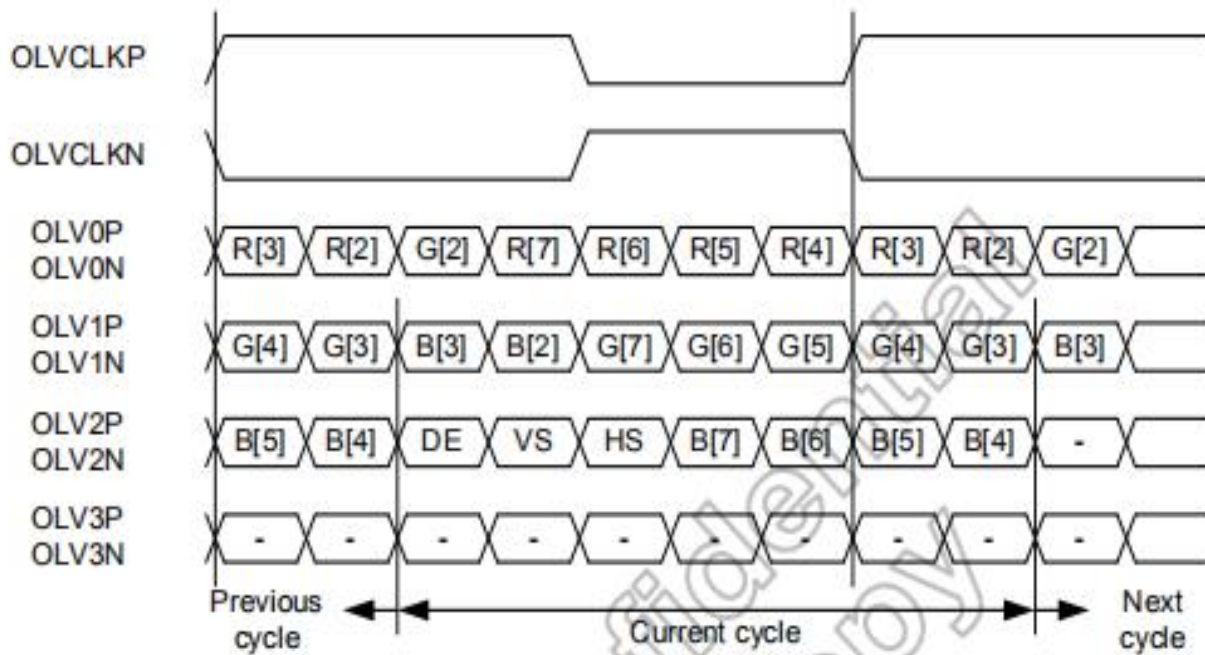

6bit mode

6.7 Input timing table

| Parameter | Symbol | 1024xRGBx768 | | | Unit |
|-----------------------|----------|----------------|------------|------|------|
| | | Min. | Typ. | Max. | |
| | | DCLK frequency | F_{DCLK} | 49.0 | |
| Horizontal valid data | t_{hd} | 1024 | | | DCLK |
| 1 Horizontal line | t_h | 1053 | 1066 | 1331 | DCLK |
| Vertical valid data | t_{vd} | 768 | | | H |
| 1 Vertical field | t_v | 775 | 781 | 998 | H |
| Frame rate | FR | - | 60 | - | Hz |

7. Optical Characteristics

| Item | Symbol | Condition | Min. | Typ. | Max. | Unit | Note | |
|-------------------------|--------------------------------|------------------------------------|------------------------------------|--------------|-------|-------------------|------|-----|
| Brightness | Bp | $\theta=0^\circ$ $\Phi=0^\circ$ | - | 500 | - | Cd/m ² | 1 | |
| Uniformity | Δ Bp | | 75 | 80 | - | % | 1,2 | |
| Viewing Angle | 3:00 | Cr \geq 10 | 75 | 80 | - | Deg | 3 | |
| | 6:00 | | 75 | 80 | - | | | |
| | 9:00 | | 75 | 80 | - | | | |
| | 12:00 | | 75 | 80 | - | | | |
| Contrast Ratio | Cr | Ta=25°C $\Phi=0^\circ$ | 800 | 1000 | - | - | 4 | |
| Response Time | T _r +T _f | | - | 22 | 25 | ms | 5 | |
| Color of CIE Coordinate | W | x | $\theta=0^\circ$ $\Phi=0^\circ$ | Typ -0.05 | 0.302 | Typ +0.05 | - | 1,6 |
| | | y | | | 0.326 | | - | |
| | R | x | | | 0.638 | | - | |
| | | y | | | 0.319 | | - | |
| | G | x | | | 0.265 | | - | |
| | | y | | | 0.577 | | - | |
| | B | x | | | 0.141 | | - | |
| | | y | | | 0.091 | | - | |
| NTSC Ratio | S | - | 70 | - | % | | | |

Note: The parameter is slightly changed by temperature, driving voltage and materiel

Note 1: The data are measured after LEDs are turned on for 5 minutes. LCM displays full white. The brightness is the average value of 9 measured spots. Measurement equipment BM-7 (Φ5mm)

Measuring condition:

- *Measuring surroundings: Dark room.*
- *Measuring temperature: $T_a=25\text{ }^\circ\text{C}$.*
- *Adjust operating voltage to get optimum contrast at the center of the display.*

Measured value at the center point of LCD panel after more than 5 minutes while backlight turning on.

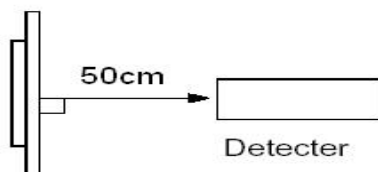

Note 2: The luminance uniformity is calculated by using following formula.

$$\Delta B_p = B_p (\text{Min.}) / B_p (\text{Max.}) \times 100 (\%)$$

$B_p (\text{Max.})$ = Maximum brightness in 9 measured spots

$B_p (\text{Min.})$ = Minimum brightness in 9 measured spots.

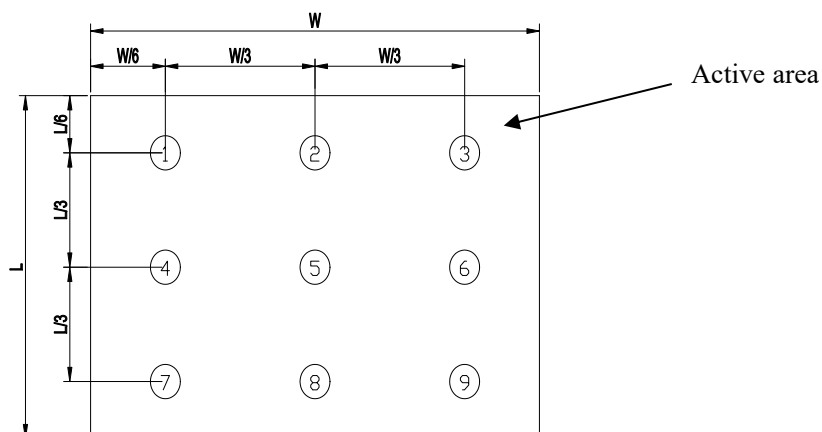

Note 3: The definition of viewing angle:
Refer to the graph below marked by θ and Φ

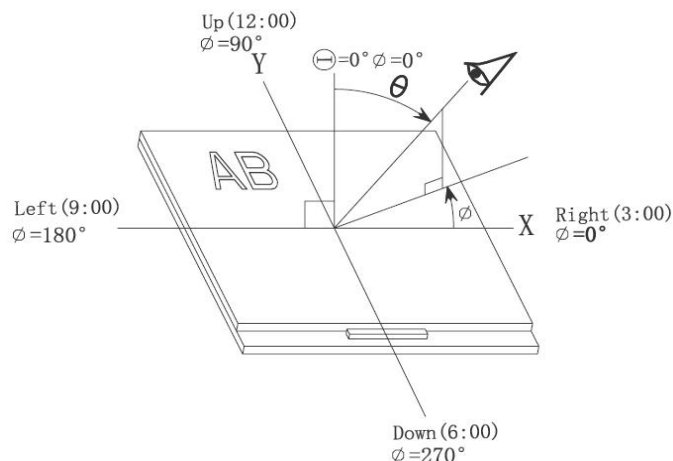

Note 4: Definition of contrast ratio.(Test LCD using DMS501)

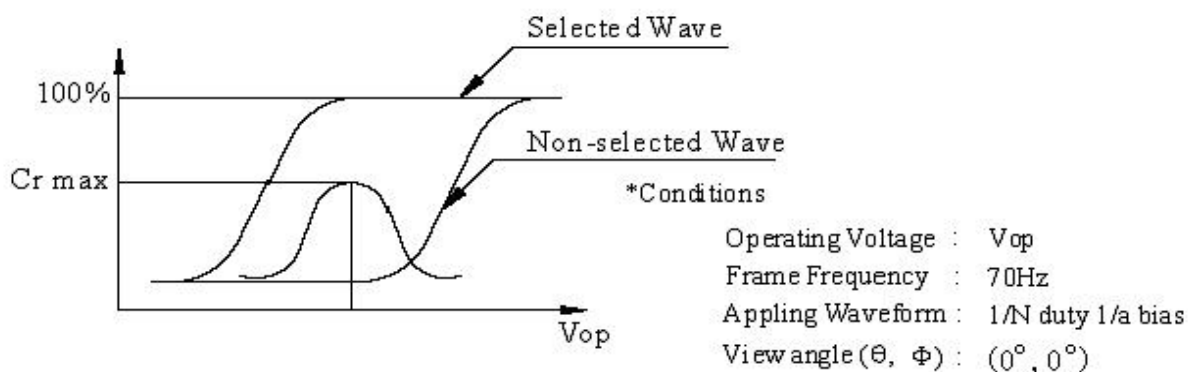

$$\text{Contrast ratio}(Cr) = \frac{\text{Brightness of selected dots}}{\text{Brightness of non-selected dots}}$$

Note 5: Definition of Response time. (Test LCD using DMS501):

The output signals of photo detector are measured when the input signals are changed from "black" to "white" (falling time) and from "white" to "black" (rising time), respectively. The response time is defined as the time interval between the 10% and 90% of amplitudes. Refer to figure as below.

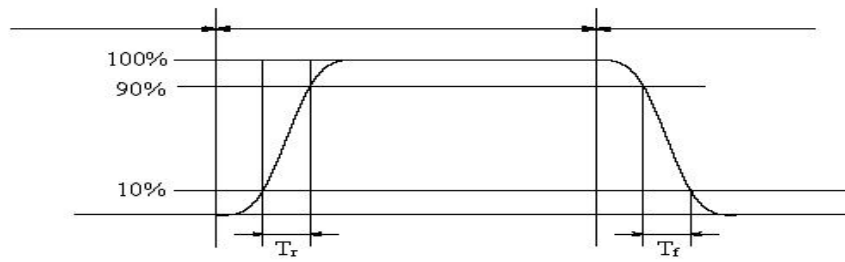

The definition of response time

Note 6: Definition of Color of CIE Coordinate and NTSC Ratio.

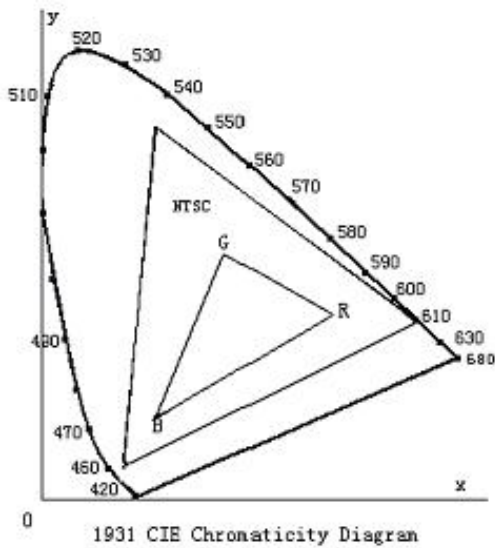

Color gamut:

$$S = \frac{\text{area of RGB triangle}}{\text{area of NTSC triangle}} \times 100\%$$

Note 7: Definition of cross talk.

Cross talk ratio(%) = $\frac{|\text{pattern A Brightness} - \text{pattern B Brightness}|}{\text{pattern A Brightness}} \times 100$

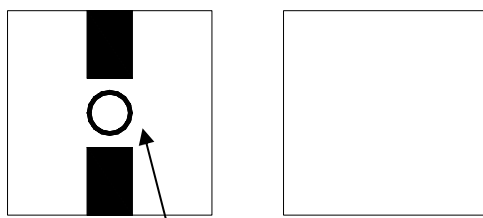

Pattern A

Pattern B

Measurement point(center)

Electric volume value = $3F \pm 3Hex$

8. Reliability Test Items and Criteria

| Test Item | Test condition | Remark |
|--|--|----------------|
| High Temperature Storage | Ta = 80°C 240hrs | Note1,Note3, 4 |
| Low Temperature Storage | Ta = -30°C 240hrs | Note1,Note3, 4 |
| High Temperature Operation | Ta = 80°C 240hrs | Note2,Note3, 4 |
| Low Temperature Operation | Ta = -30°C 240hrs | Note1,Note3, 4 |
| Operation at High Temperature/Humidity | +60°C, 90%RH 240hrs | Note3, 4 |
| Thermal Shock | -30°C/30 min ~ +80°C/30 min for a total 50 cycles, Start with cold temperature and end with high temperature. | Note3, 4 |
| Vibration Test | Frequency range:10~55Hz Stroke:1.5mm Sweep:10Hz~55Hz~10Hz 2 hours for each direction of X. Y. Z. (6 hours for total) | |
| Mechanical Shock (NON-OPERATION) | Shock level: 1470 m/s ² (150G) Waveform: half sinusoidal wave, 2 ms Number of shocks: one shock input in each direction of three mutually perpendicular axes for a total of six shock inputs | |
| Vibration Test (NON-OPERATION) | Vibration level: 9.8 m/s ² (1.0G) Waveform: sinusoidal Frequency range: 5 to 500 Hz Frequency sweep rate: 0.5 octave /min Duration: one sweep from 5 to 500 Hz in each of three mutually perpendicular axis(each x,y,z axis: 1 hour, total 3 hours) | |
| Package Drop Test | Height:60cm 1 corner, 3 edges, 6 surfaces | |
| CONTACT DISCHARGE (OPERATION) | 150pF, 330Ω , 8kV, 10 times at 1 sec interval | |
| SIGNAL PIN DISCHARGE (NON-OPERATION) | 200pF, 0Ω , 200V, 10 times at 1 sec interval | |

Note 1: T_a is the ambient temperature of samples.

Note 2: T_s is the temperature of panel's surface.

Note 3: In the standard condition, there shall be no practical problem that may affect the display function. After the reliability test, the product only guarantees operation, but don't guarantee all of the cosmetic specification.

Note 4: Before cosmetic and function test, the product must have enough recovery time, at least 2 hours at room temperature

9. Precautions for Use of LCD Modules

9.1 Handling Precautions

9.1.1 *The display panel is made of glass. Do not subject it to a mechanical shock by dropping it from a high place, etc.*

9.1.2 *If the display panel is damaged and the liquid crystal substance inside it leaks out, be sure not to get any in your mouth, if the substance comes into contact with your skin or clothes, promptly wash it off using soap and water.*

9.1.3 *Do not apply excessive force to the display surface or the adjoining areas since this may cause the color tone to vary.*

9.1.4 *The polarizer covering the display surface of the LCD module is soft and easily scratched. Handle this polarizer carefully.*

9.1.5 *If the display surface is contaminated, breathe on the surface and gently wipe it with a soft dry cloth. If still not completely clear, moisten cloth with one of the following solvents:*

— Isopropyl alcohol — Ethyl alcohol

Solvents other than those mentioned above may damage the polarizer. Especially, do not use the following:

— Water — Ketone — Aromatic solvents

9.1.6 *Do not attempt to disassemble the LCD Module.*

9.1.7 *If the logic circuit power is off, do not apply the input signals.*

9.1.8 *To prevent destruction of the elements by static electricity, be careful to maintain an*

optimum work environment.

- a. Be sure to ground the body when handling the LCD Modules.*
- b. Tools required for assembly, such as soldering irons, must be properly ground.*
- c. To reduce the amount of static electricity generated, do not conduct assembly and other work under dry conditions.*
- d. The LCD Module is coated with a film to protect the display surface. Be care when peeling off this protective film since static electricity may be generated.*

9.2 Storage precautions

9.2.1 When storing the LCD modules, avoid exposure to direct sunlight or to the light of fluorescent lamps.

9.2.2 The LCD modules should be stored under the storage temperature range. If the LCD modules will be stored for a long time, the recommend condition is:

Temperature : 0 °C ~ 40 °C

Relatively humidity: ≤80%

9.2.3 The LCD modules should be stored in the room without acid, alkali and harmful gas.

9.3 The LCD modules should be no falling and violent shocking during transportation, and also should avoid excessive press, water, damp and sunshine.

END

Our company network supports you worldwide with offices in Germany, Austria, Switzerland, the UK and the USA. For more information please contact:

Headquarters

Germany



FORTEC Elektronik AG

Augsburger Str. 2b
82110 Germering

Phone: +49 89 894450-0
E-Mail: info@forteca.de
Internet: www.forteca.de

Fortec Group Members

Austria



Distec GmbH Office Vienna

Nuschinggasse 12
1230 Wien

Phone: +43 1 8673492-0
E-Mail: info@distec.de
Internet: www.distec.de

Germany



Distec GmbH

Augsburger Str. 2b
82110 Germering

Phone: +49 89 894363-0
E-Mail: info@distec.de
Internet: www.distec.de

Switzerland



ALTRAC AG

Bahnhofstraße 3
5436 Würenlos

Phone: +41 44 7446111
E-Mail: info@altrac.ch
Internet: www.altrac.ch

United Kingdom



Display Technology Ltd.

Osprey House, 1 Osprey Court
Hichingbrooke Business Park
Huntingdon, Cambridgeshire, PE29 6FN

Phone: +44 1480 411600
E-Mail: info@displaytechnology.co.uk
Internet: www.displaytechnology.co.uk

USA



Apollo Display Technologies, Corp.

87 Raynor Avenue,
Unit 1 Ronkonkoma,
NY 11779

Phone: +1 631 5804360
E-Mail: info@apolloDisplays.com
Internet: www.apolloDisplays.com