



OUR GLOBAL
COMPETENCE
CENTRES

 APOLLO DISPLAY
TECHNOLOGIES



 DISTEC



 DISPLAY
TECHNOLOGY



Datasheet

Ortustech

COM50H5N03ULC

OR-20-013

Specifications for
Blanview TFT-LCD Monitor
(5.0" HD 720 x RGB x 1280 Portrait)

Version 3.0

(Please be sure to check the specifications latest version.)

MODEL COM50H5N03ULC

Customer's Approval

Signature:

Name:

Section:

Title:

Date:

ORTUSTECH

TOPPAN PRINTING CO.,LTD.
Electronics Division
Ortus Subdivision

Approved by

_____ *Y. Nakajima*





Checked by

_____ *S. Kawayama*

Prepared by

_____ *M. Shibamoto*

Version History

Ver.	Date	Page	Description	
0.0	Apr. 18, 2017	-	-	Tentative issue
0.1  ×19	Dec. 1, 2017	2	change	Contents
		4	add	Display type
		6	add	3.1 Dimensions
		10	change	Absolute Maximum Rating
		10	change	Recommended Operating Conditions
		12	add	7.1.3 Backlight
		20	change	9.1 Power-ON Sequence
		21	change	Power-ON Sequence
		25	add	9.2 Power-OFF Sequence
		26	change	9.6. External Power on/off Sequence
		31	add	Driving condition:
		32	add	White Chromaticity Range
		32	add	Driving condition:
		37	add	Packing Specifications
39	add	Precautions for Handling		
40	add	Maximum piling up		
41	add	Precautions for Peeling off the Protective film		
42	change	Measurement Condition (Backlight ON)		
43	change	Measurement Condition (Contrast ratio Backlight OFF only)		
1.0  ×8	Feb.8,2018	-	-	First issue
		5	add	Foot note
		12	add	7.1.1 Display Module
		21	change	9.1 Power-ON Sequence
		32	change	12.1 Optical Characteristics
		33	change	12.2 Temperature Characteristics
		34	add	13.1 Defective Display and Screen Quality
		35	add	Glass chipping
36	add	14. Reliability Test		
2.0  ×2	Sep.7,2018	23	change	Fixed typographical error
		36	add	Lightfastness
3.0  ×8	Nov.12,2019	all page	correction	It is a company name change from ORTUS TECHNOLOGY CO.,LTD to TOPPAN PRINTING CO.,LTD.
		4	change	RoHS(2.0) directive
		21,22	change	Update of Parameter
		32,33	change	CS1000→CS2000
		43	change	CS1000→CS2000, Distance between monitor and luminance meter
45	change	Test Method		

Contents

1. Application	3
2. Outline Specifications		
2.1 Features of the Product	4
2.2 Display Method	4
3. Dimensions and Shape		
3.1 Dimensions	6
3.2 Outward Form	7
3.3 Serial № print (S-print)	8
4. Pin Assignment	9
5. Absolute Maximum Rating	10
6. Recommended Operating Conditions	10
7. Characteristics		
7.1 DC Characteristics		
7.1.1 Display Module	11
7.1.2 MIPI DSI Interface	11
7.1.3 Backlight	12
7.2 AC Characteristics		
7.2.1 HS-RX Specifications	13
7.2.2 LP-TX Specifications	13
7.2.3 RX/TX Specifications	14
7.2.4 Reset input timing	16
7.3 Input Timing Characteristics	16
7.4 Input Signal Timing Chart	17
8. About MIPI Interface		
8.1 Version	18
8.2 DSI protocol	18
8.3 Packet data types	19
8.4 Packet Footer on the long packet	19
9. Sequence		
9.1 Power-ON Sequence	20
9.2 Power-OFF Sequence	25
9.3 Sleep Sequence	25
9.4 Sleep Release Sequence	25
9.5 ULPS (Ultra-low power state) Enter/Exit Sequence	25
9.6 External Power on/off Sequence	26
10. Content adaptive brightness control (CABC) function		
10.1 CABC Block diagram	28
10.2 CABC Block	28
10.3 Brightness control block	29
10.4 Minimum brightness setting of CABC function	29
10.5 CABC commnd list	29
11. LED Circuit	31
12. Characteristics		
12.1 Optical Characteristics	32
12.2 Temperature Characteristics	33
13. Criteria of Judgment		
13.1 Defective Display and Screen Quality	34
13.2 Screen and Other Appearance	35
14. Reliability Test	36
15. Packing Specifications	38
16. Handling Instruction		
16.1 Cautions for Handling LCD panels	39
16.2 Precautions for Handling	40
16.3 Precautions for Operation	40
16.4 Storage Condition for Shipping Cartons	41
16.5 Precautions for Peeling off the Protective film	42
16.6 Warranty	42
APPENDIX	43

1. Application

This Specification is applicable to 126.0 mm (5.0 inch) Blanview TFT-LCD monitor for non-military use.

- ◎ TOPPAN PRINTING makes no warranty or assume no liability that use of this Product and/or any information including drawings in this Specification by Purchaser is not infringing any patent or other intellectual property rights owned by third parties, and TOPPAN PRINTING shall not grant to Purchaser any right to use any patent or other intellectual property rights owned by third parties. Since this Specification contains TOPPAN PRINTING's confidential information and copy right, Purchaser shall use them with high degree of care to prevent any unauthorized use, disclosure, duplication, publication or dissemination of TOPPAN PRINTING's confidential information and copy right.
- ◎ If Purchaser intends to use this Products for an application which requires higher level of reliability and/or safety in functionality and/or accuracy such as transport equipment (aircraft, train, automobile, etc.), disaster-prevention/security equipment or various safety equipment, Purchaser shall consult TOPPAN PRINTING on such use in advance.
- ◎ This Product shall not be used for application which requires extremely higher level of reliability and/or safety such as aerospace equipment, telecommunication equipment for trunk lines, control equipment for nuclear facilities or life-support medical equipment.
- ◎ It must be noted as an mechanical design manner, especial attention in housing design to prevent arcuation/flexureor caused by stress to the LCD module shall be considered.
- ◎ TOPPAN PRINTING assumes no liability for any damage resulting from misuse, abuse, and/or miss-operation of the Product deviating from the operating conditions and precautions described in the Specification.
- ◎ It shall be mutually conferred if nonconforming defect which result from unspecified cause in this specification arises.
- ◎ If any issue arises as to information provided in this Specification or any other information, TOPPAN PRINTING and Purchaser shall discuss them in good faith and seek solution.
- ◎ TOPPAN PRINTING assumes no liability for defects such as electrostatic discharge failure occurred during peeling off the protective film or Purchaser's assembly process.



- ◎ This Product is compatible for RoHS(2.0) directive.

Object substance	Maximum content [ppm]
Cadmium and its compound	100
Hexavalent Chromium Compound	1000
Lead & Lead compound	1000
Mercury & Mercury compound	1000
Polybrominated biphenyl series (PBB series)	1000
Polybrominated biphenyl ether series (PBDE series)	1000
Bis(2-ethylhexyl)phthalate series(DEHP series)	1000
Butyl benzyl phthalate series(BBP series)	1000
Dibutyl phthalate series(DBP series)	1000
Diisobutyl phthalate series(DIBP series)	1000

2. Outline Specifications

2.1 Features of the Product

- 5.0 inch diagonal display, 720 x RGB [H] x 1280 [V] dots.
- 24bitRGB (8-8-8 Format) / 16.7 Million colors.
- MIPI DSI as high-speed interface. Video mode only.
- Timing generator [TG], Counter-electrode driving circuitry, Built-in power supply circuit.
- Various display controls and functional selection.
- Long life & High bright white LED back-light.
- Blanview TFT-LCD, improved outdoor readability.

* MIPI : Mobile Industrial Processor Interface , DSI : Display Serial Interface

	Indoor		Outdoor	
	Readability	Power Efficiency (Battery Life)	Readability	Power Efficiency (Battery Life)
Transmissive	Good	Good	Fair	Poor
Transflective	Fair	Poor	Good	Good
Blanview	Good	Good	Good	Good

2.2 Display Method

Items	Specifications	Remarks
Display type	VA 16.7 Million colors. Blanview, Normally black.	
Driving method	a-Si TFT Active matrix. Line-scanning, Non-interface.	
Dot arrangement	RGB stripe arrangement.	Refer to "Dot arrangement"
Signal input method	MIPI DSI 4-lanes : 4 data lanes and 1 clock lane	in foot note 1
Backlight type	Long life & High bright white LED.	
NTSC ratio	50%	

Foot note1: when use MIPI DSI 2-lanes, Please contact TOPPAN PRINTING.

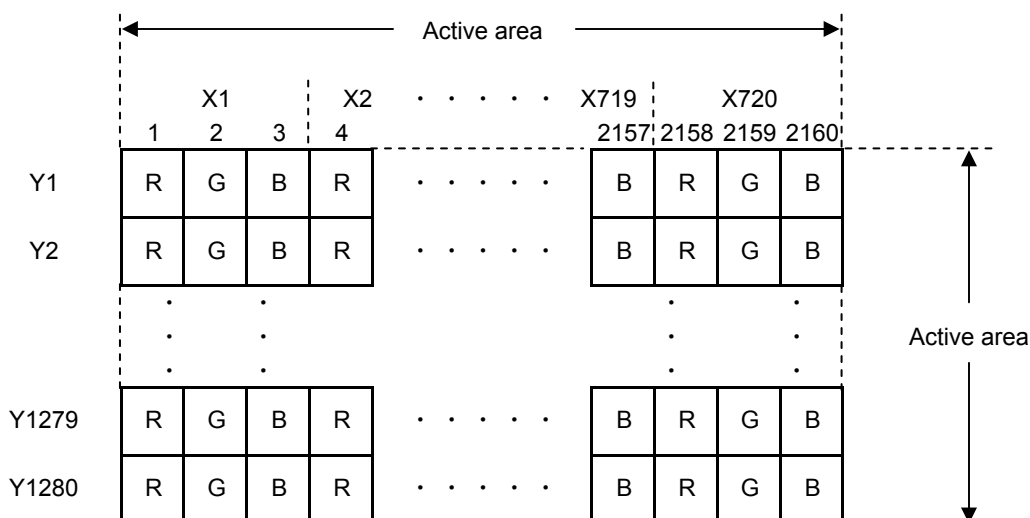
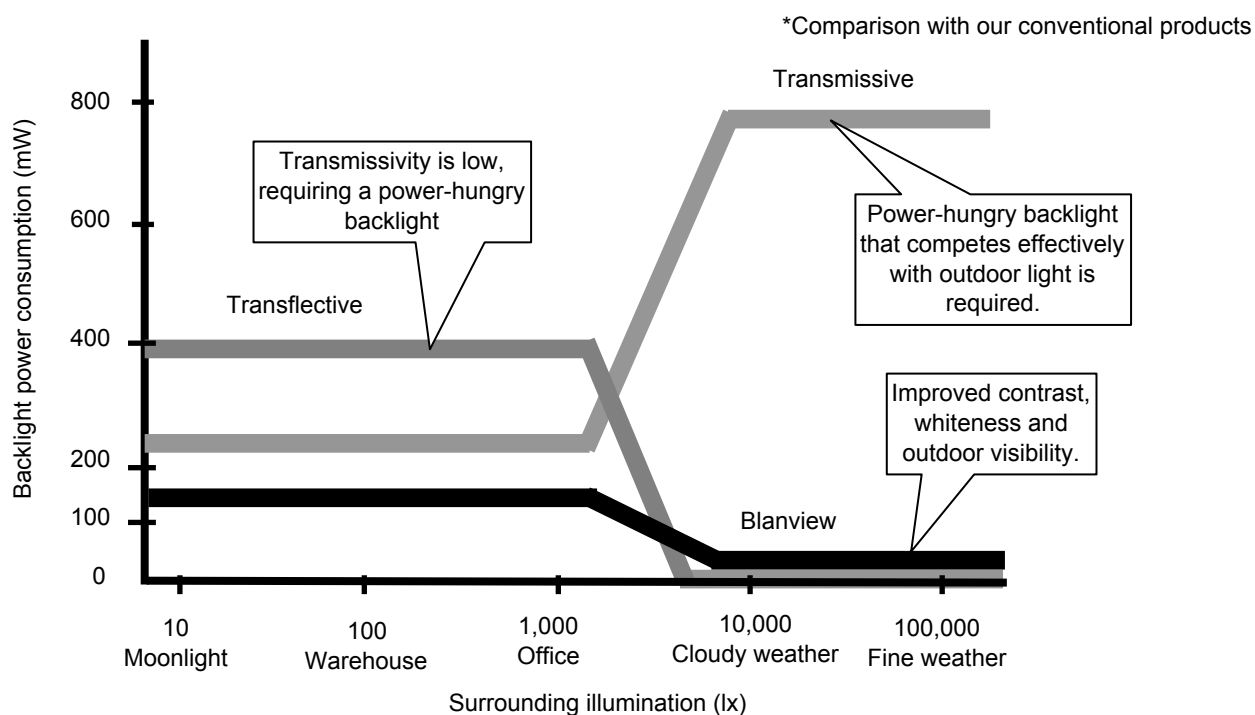

Fig.1 Dot arrangement (FPC cable placed lower right)

<Features of Blanview>

- Backlight power consumption required to assure visibility. (equivalent to 3.5"QVGA)



- Contrast characteristics under 100,000lx. (same condition as direct sunlight.)

With better contrast (higher contrast ratio), Blanview TFT-LCD has the best outdoor readability in three different types of TFT-LCD.

Below chart shows contrast value against panel surface brightness. (Horizontal: Panel surface brightness/ Vertical: Contrast value) LCD panel has enough outdoor readability above our Standard line. (TOPPAN PRINTING criteria)

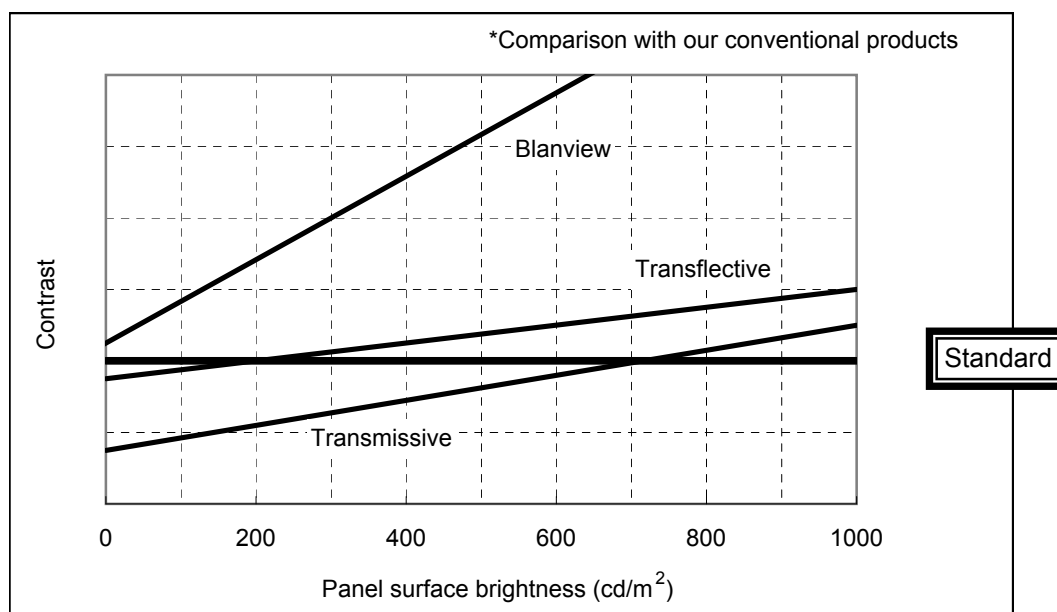

3. Dimensions and Shape

3.1 Dimensions

Items	Specifications	Unit	Remarks
Outline dimensions	67.84 [H] × 120.22 [V] × 2.15 [D]	mm	Exclude FPC cable
Active area	61.776[H] × 109.824[V]	mm	126.0mm diagonal
Number of dots	2160[H] × 1280[V]	dot	
Dot pitch	28.6[H] × 85.8[V]	um	
Surface hardness of the polarizer	2	H	Load : 2.94N
Weight	34	g	

3.3 Serial № print (S-print)

1) Display Items

S-print indicates the least significant digit of manufacture year (1digit), manufacture month with below alphabet (1letter), model code (5characters), serial number (6digits).

* Contents of Display

*	*	*****	*****
-	-	-----	-----
a	b	c	d

Contents of display				
a	The least significant digit of manufacture year			
b	Manufacture month	Jan-A Feb-B Mar-C Apr-D	May-E Jun-F Jul-G Aug-H	Sep-I Oct-J Nov-K Dec-L
c	Model code	50BTC (Made in Japan) 50BVC (Made in Malaysia)		
d	Serial number			

* Example of indication of Serial № print (S-print)

•Made in Japan

8J50BTC000125

means "manufactured in October 2018, 5.0" BT type, C specifications, serial number 000125"

•Made in Malaysia

8J50BVC000125

means "manufactured in October 2018, 5.0" BV type, C specifications, serial number 000125"

2) Location of Serial № print (S-print)

Refer to 3.2 "Outward Form".

3)Others

Please note that it is likely to disappear with an organic solvent about the Serial print.

4. Pin Assignment

No.	Symbol	Details	Remark	IO
1	GND	Ground		P
2	NC	Non connection		-
3	LED+	Backlight LED Anode		P
4	NC	Non connection		-
5	LED-	Backlight LED Cathode		P
6	VDD	Analog Power Supply	VDD = 2.9V (TYP)	P
7	GND	Ground		P
8	VCCIO	DSI and I/O Power Supply	VCCIO = 1.9V (TYP)	P
9	RESETB	LCD Reset	L:Initialize Power_ON Reset is Required when Turning on the Power	I
10	GND	Ground		P
11	PWM	CACB PWM OUT		O
12	GND	Ground		P
13	DSI_D3P	MIPI-DSI Data differential signal input pin (Data lane 3)		I
14	DSI_D3N	MIPI-DSI Data differential signal input pin (Data lane 3)		I
15	GND	Ground		P
16	DSI_D2P	MIPI-DSI Data differential signal input pin (Data lane 2)		I
17	DSI_D2N	MIPI-DSI Data differential signal input pin (Data lane 2)		I
18	GND	Ground		P
19	DSI_CP	MIPI-DSI Clock differential signal input pin		I
20	DSI_CN	MIPI-DSI Clock differential signal input pin		I
21	GND	Ground		P
22	D1P	MIPI-DSI Data differential signal input pin (Data lane 1)		I
23	D1N	MIPI-DSI Data differential signal input pin (Data lane 1)		I
24	GND	Ground		P
25	DSI_D0P	MIPI-DSI Data differential signal input pin (Data lane 0)		IO
26	DSI_D0N	MIPI-DSI Data differential signal input pin (Data lane 0)		IO
27	GND	Ground		P

- Recommended connector : (FH35C-27S-0.3SHW(50) /HIROSE ELECTRIC)
- Please make sure to check a consistency between pin assignment in "3.2 Outward Form" and your connector pin assignment when designing your circuit.
Inconsistency in input signal assignment may cause a malfunction.
- Since FPC cable has gold plated terminals, gilt finish contact shoe connector is recommended.

5. Absolute Maximum Rating

GND=0V

Item	Symbol	Condition	Rating		Unit	Applicable terminal
			MIN	MAX		
Supply voltage	VDD	Ta=25 °C	-0.3	4.4	V	VDD
DSI and I/O Power Supply voltage	VCCIO		-0.3	3.6	V	VCCIO
Input voltage for logic	VI		-0.3	VCCIO+0.3	V	RESETB TEST1-4
DSI Input voltage	VDSIIN		-0.15	1.45	V	DSI_D0P/N DSI_D2P/N DSI_D1P/N DSI_D3P/N DSI_CP/N
LED forward current	IL	Ta = 25 °C	-	35	mA	LED+ - LED-
		Ta = 70 °C	-	15		
Storage temperature range	Tstg		-30	80	°C	
Storage humidity range	Hstg	Non condensing in an environmental moisture at or less than 40 °C 90%RH.				

6. Recommended Operating Conditions

GND=0V

Item	Symbol	Condition	Rating			Unit	Applicable terminal
			MIN	TYP	MAX		
Supply voltage	VDD		2.8	2.9	3.0	V	VDD
DSI and I/O Power Supply voltage	VCCIO		1.8	1.9	2.0	V	VCCIO
Input voltage for logic	VI		0	-	VCCIO	V	RESETB TEST1-4
DSI Input voltage	VDSIIN		-0.15	-	1.45	V	DSI_D0P/N DSI_D2P/N DSI_D1P/N DSI_D3P/N DSI_CP/N
Operational temperature range	Top	Note1,2	-20	25	70	°C	Panel surface temperature
Operating humidity range	Hop	Ta<=40 °C	20	-	85	%	
		Ta>40 °C	Non condensing in an environmental moisture at or less than 40 °C 85%RH.				

Note1: This monitor is operatable in this temperature range. With regard to optical characteristics, refer to Item 12."Characteristics".

Note 2: Acceptable Forward Current to LED is up to 15 mA, when Ta=+70 °C.

Do not exceed Allowable Forward Current shown on the chart below.

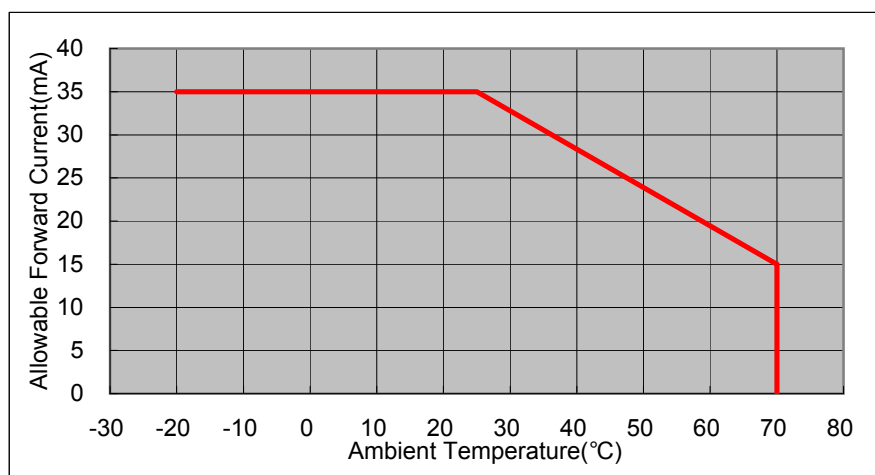

7. Characteristics

7.1 DC Characteristics

7.1.1 Display Module

(Unless otherwise noted, Ta=25 °C, VDD=2.9V, VCCIO=1.9V, GND=0V)

Item	Symbol	Condition	Rating			Unit	Applicable terminal
			MIN	TYP	MAX		
Input Signal Voltage	VIH	VCCIO=1.8-2.0V	0.8×VCCIO	-	VCCIO	V	RESETB
	VIL		0	-	0.2×VCCIO	V	
Operating Current	IDD	fDSICLK=150 MHz	-	31	62	mA	VDD
	ICCIO	Color bar display	-	15	30	mA	VCCIO
Sleep_mode Current	IDDS	Clock/Data=LP11	-	70	150	µA	VDD
	ICCIOS	Sleep_mode	-	30	100	µA	VCCIO
Output Signal Voltage	VOH	VCCIO=1.8-2.0V IOH/L=+/- 1mA	0.8×VCCIO	-	VCCIO	V	PWM
	VOL		0	-	0.2×VCCIO	V	

7.1.2 MIPI DSI Interface

Item	Symbol	Condition	Rating			Unit	Note
			MIN	TYP	MAX		
HS-RX	Differential input high threshold	VIDTH	-	-	70	mV	
	Differential input low threshold	VIDTL	-70	-	-	mV	
	Single-ended input high voltage	VIHHS	-	-	460	mV	
	Single-ended input low voltage	VILHS	-40	-	-	mV	
	Common-mode voltage HS receive mode	VCMRXD C	70	-	330	mV	
	Differential input impedance	ZID	80	100	125	Ohm	
LP-RX	Logic 1 input voltage	VIH	880	-	-	mV	
	Logic 0 input voltage	VIL	-	-	550	mV	
LP-TX	Thevenin output low level	VOL	-50	-	50	mV	
	Thevenin output high level	VOH	1.1	1.2	1.3	V	
	Output impedance of LP transmitter	ZOLP	110	-	-	Ohm	
CD-RX	Logic 1 contention threshold	VIHCD	450	-	-	mV	
	Logic 0 contention threshold	VILCD	-	-	200	mV	

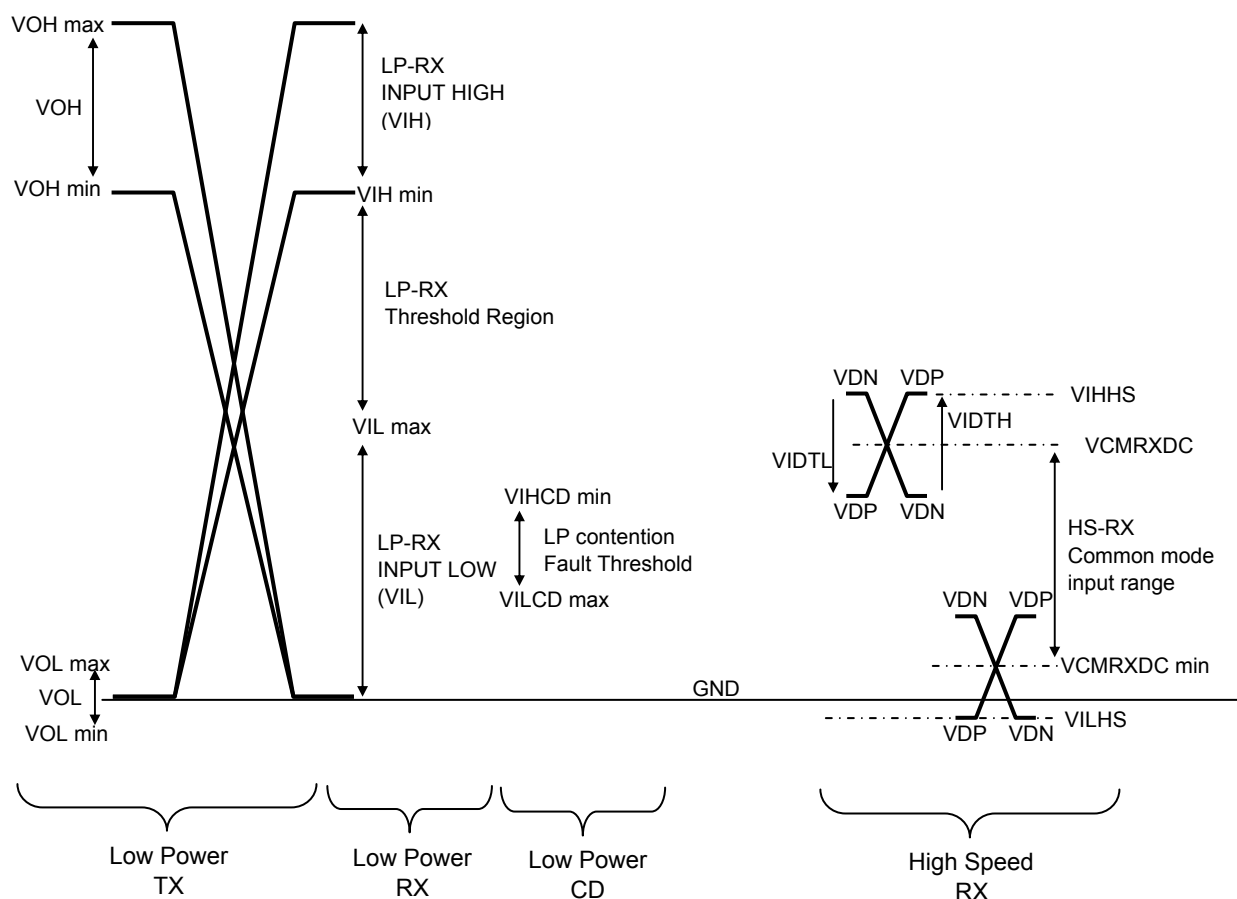

The signal levels for the LP and HS .

7.1.3 Backlight

Item	Symbol	Condition	Rating			Unit	Applicable terminal
			MIN	TYP	MAX		
Forward current	IL25	Ta=25 °C	--	10	35	mA	LED+ - LED-
	IL70	Ta=70 °C	--	--	15	mA	
Forward voltage (*Reference only)	VL	Ta=25 °C IL=10mA	20.6*	22.0*	23.2*	V	
Estimated Life of LED	LL	Ta=25 °C IL=10mA Note	--	50,000	--	hrs	

- Note: - The lifetime of the LED is defined as a period till the brightness of the LED decreases to the half of its initial value.
- This figure is given as a reference purpose only, and not as a guarantee.
 - This figure is estimated for an LED operating alone.
- As the performance of an LED may differ when assembled as a monitor together with a TFT panel due to different environmental temperature.
- Estimated lifetime could vary on a different temperature and usually higher temperature could reduce the life significantly.

7.2 AC Characteristics

7.2.1 HS-RX Specifications

(Unless otherwise noted, $T_a=25\text{ }^\circ\text{C}$, $V_{DD}=2.9\text{V}$, $V_{CCIO}=1.9\text{V}$, $GND=0\text{V}$)

Item	Symbol	Condition	Rating			Unit	Applicable terminal
			MIN	TYP	MAX		
DSICLK Frequency	f DSICLK	Fig.B	40	-	250	MHz	CP/N
DSICLK Cycle time	TCLKP		4.0	-	25.0	ns	
DSI Data Transfer Rate	UI		2.0	-	12.5	ns	D0P/N,D1P/N
	t DSIR		80	-	500	Mbps	D2P/N,D3P/N
Data to Clock Setup Time	Tsetup		0.15	-	-	UI	D0P/N,D1P/N
Clock to Data Hold Time	Thold	0.15	-	-	UI	D2P/N,D3P/N,CP/N	

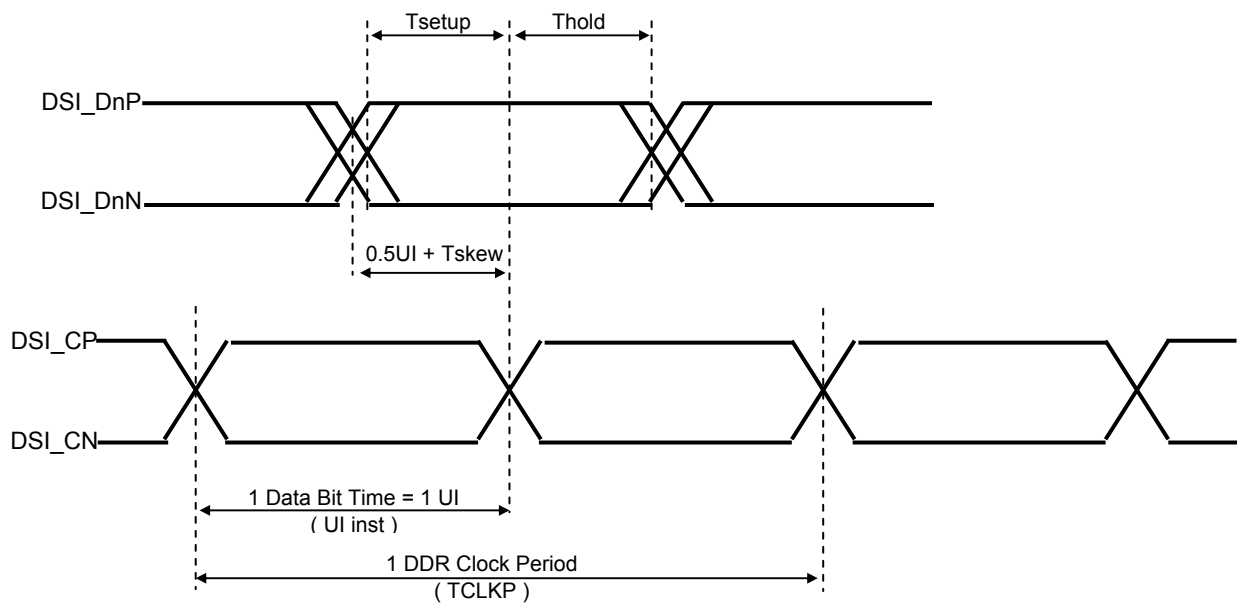

Data to Clock Timing Definitions

7.2.2 LP-TX Specifications

(Unless otherwise noted, $T_a=25\text{ }^\circ\text{C}$, $V_{DD}=3.3\text{V}$, $V_{CCIO}=1.8\text{V}$, $GND=0\text{V}$)

Item	Symbol	Condition	Rating			Unit	Applicable terminal
			MIN	TYP	MAX		
15% - 85% rise time	TRLP		-	-	25	ns	D0P/N
85% - 15% fall time	TFLP		-	-	25	ns	
Slew rate	$\Delta V / \Delta t_{SR}$	Clload = 70pF	-	-	150	mV/ns	

7.2.3 RX/TX Specifications

(Unless otherwise noted, $T_a=25\text{ }^\circ\text{C}$, $V_{DD}=2.9\text{V}$, $V_{CCIO}=1.9\text{V}$, $GND=0\text{V}$)

Item	Description	Rating			Unit
		MIN	TYP	MAX	
$T_{HS-PREPARE}$	Time to drive LP00 to prepare for HS transmission	40 ns + 4UI	-	85 ns + 6UI	
$T_{HS-PREPARE} + T_{HS-ZERO}$	$T_{HS-PREPARE}$ + Time to drive HS0 before the SYNC sequence	145 ns + 10UI	-	-	
$T_{HS-TRAIL}$	Time to drive flipped differential state after last payload data bit of a HS transmission burst	$\max(n*8\text{UI}, 60\text{ ns} + n*4\text{UI})$	-	-	
$T_{HS-EXIT}$	Time to drive LP11 after HS burst	100	-	-	ns
T_{TA-GO}	Time to drive LP00 after Turnaround Request	$4*T_{LPTX}$			
$T_{TA-SURE}$	Time out before new TX side starts driving	T_{LPTX}	-	$2*T_{LPTX}$	
T_{TA-GET}	Time to drive LP00 by new TX	$5*T_{LPTX}$			
T_{LPX}	Length of any Low Power state period	50	-	-	ns
Ratio T_{LPX}	Ratio of $T_{LPX}(\text{MASTER})/T_{LPX}(\text{SLAVE})$ between Master and Slave side	2/3	-	3/2	
$T_{CLK-POST}$	Time that the transmitter shall continue sending HS clock after the last associated Data Lane has transitioned to LP mode	60 ns + 52UI	-	-	
$T_{CLK-PREPARE} + T_{CLK-ZERO}$	$T_{CLK-PREPARE}$ + time for lead HS-0 drive period before starting Clock	300	-	-	ns
$T_{CLK-PRE}$	Time that the HS clock shall be driven prior to any associated Data Lane beginning the transition from LP to HS mode	8	-	-	UI
$T_{CLK-PREPARE}$	Time to drive LP-00 to prepare for HS clock transmission	38	-	95	ns
$T_{CLK-TRAIL}$	Time to drive HS differential state after last payload clock bit of a HS transmission burst	60	-	-	ns
T_{EOT}	Time from start of $T_{HS-TRAIL}$ period to start of LP-11 state	-	-	105 ns + $n*12\text{UI}$	
T_{LPTX1}	Length of Low-Power TX state period in case of using DSI clock	-	$n*DSITX$	-	UI
T_{LPTX2}	Length of Low-Power TX state period in case of using internal OSC clock	-	1/fosc	-	ns

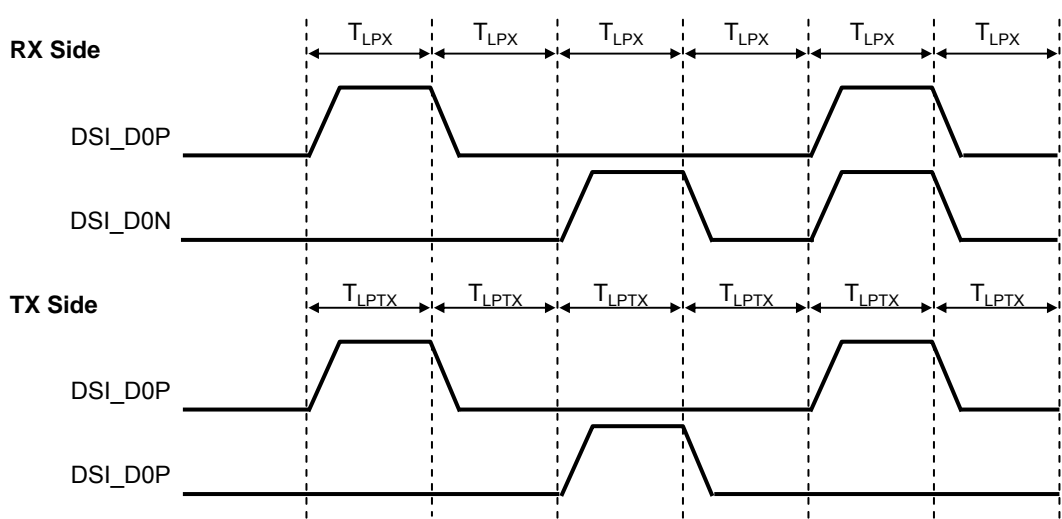
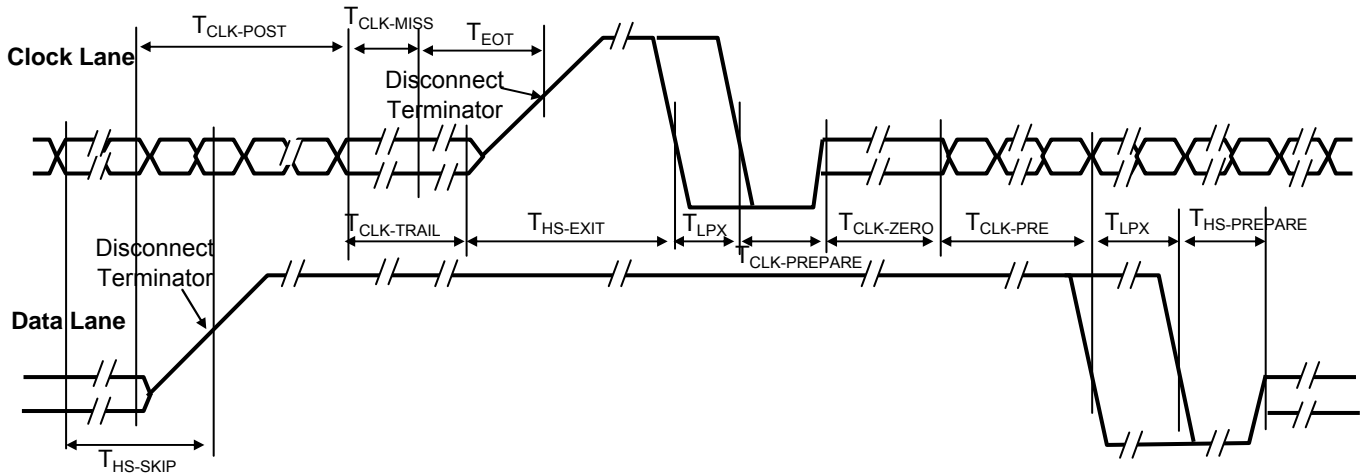
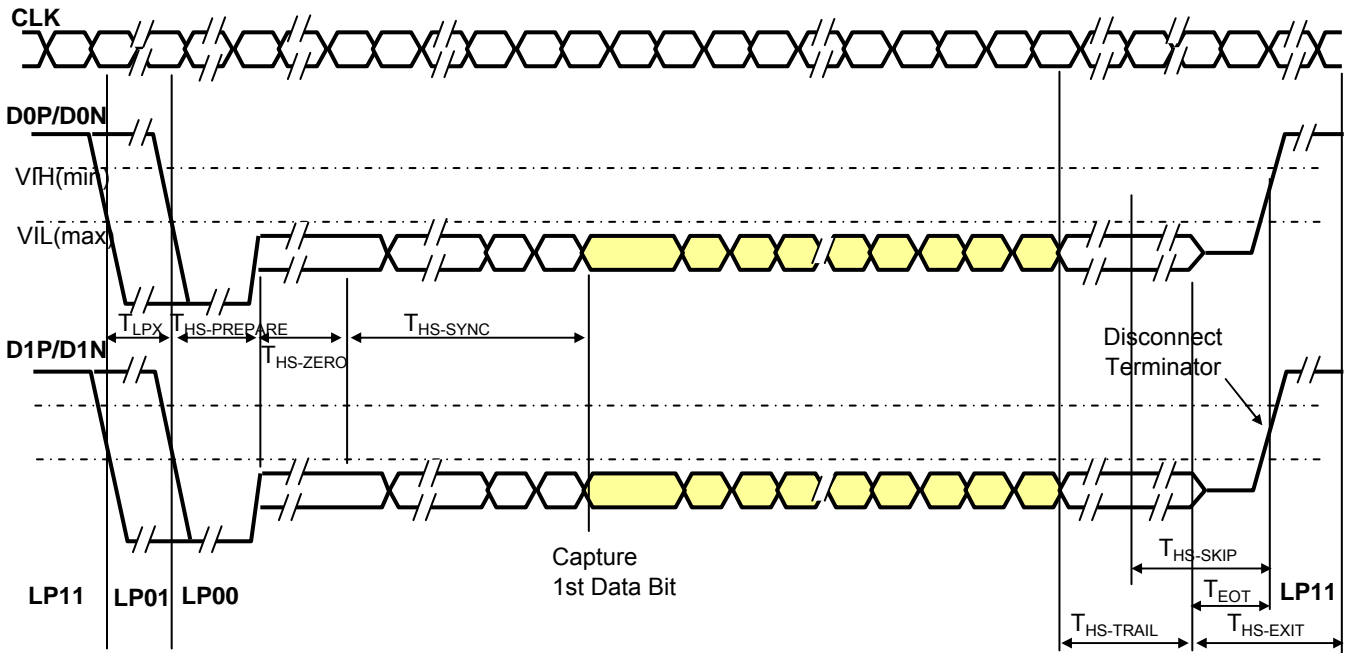
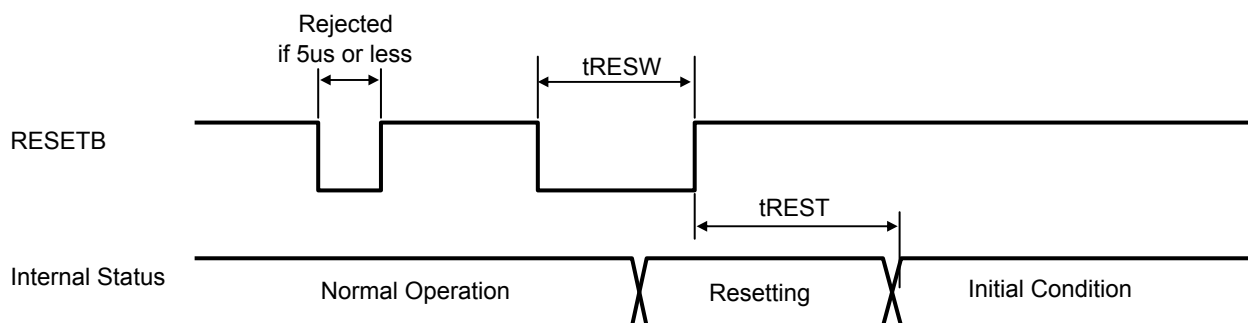

Fig.E DSI LP Mode

7.2.4 Reset input timing

Item	Symbol	Condition	Rating			Unit	Remark
			MIN	TYP	MAX		
Reset Low Pulse width	tRESW		20	-	-	us	
Reset Complete time	tREST	during Sleep In	10	-	-	ms	
		during Sleep Out	120	-	-	ms	



RESETB input timing

7.3 Input Timing Characteristics

Item	Symbol	Condition	Rating			Unit	Remark
			MIN	TYP	MAX		
CLK Frequency	fPCLK	Fig.G	62.5	67.3	-	MHz	PCLK
VSYNC Frequency	Note fVSYNC		54	58.1	66	Hz	VSYNC
VSYNC Cycle	tv		1292	1292	-	H	
VSYNC Pulse Width	VS		3	3	-	H	
Vertical Back Porch	tvb		3	3	-	H	
Vertical Front Porch	tvf		6	6	-	H	
Vertical data start Point	VS+tvb		6	6	-	H	
Vertical Blanking Period	VS+tvb+tvf		12	12	-	H	
Vertical Display Period	tvdP		-	1280	--	H	
HSYNC frequency	fHSYNC		69.8	75.1	-	kHz	HSYNC
HSYNC Cycle	th		-	896	-	CLK	
HSYNC Pulse Width	HS		-	15	-	CLK	
Horizontal Back Porch	thb		-	70	-	CLK	
Horizontal Front Porch	thf		-	91	-	CLK	
Horizontal data start Point	HS+thb	-	85	-	CLK		
Horizontal Blanking Period	HS+thb+thf	-	176	-	CLK		
Horizontal Display Period	thdp	-	720	-	CLK		

Note: This is recommended spec to get high quality picture on display. It is customer's risk to use out of this frequency.

7.4 Input Signal Timing Chart

-Vertical Timing

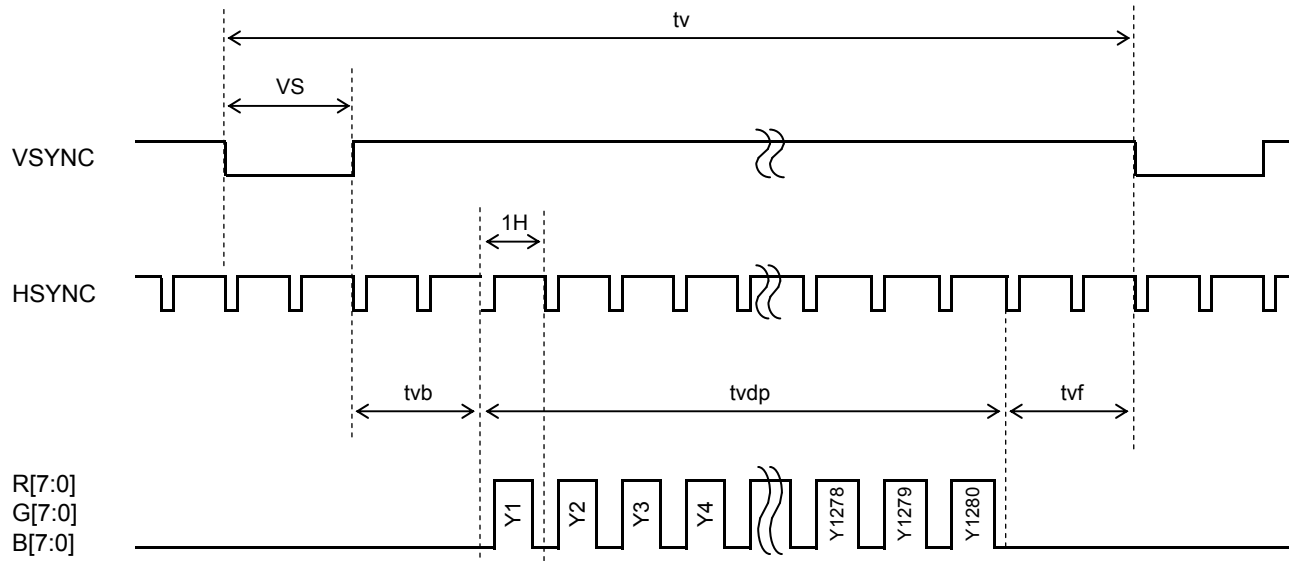

-Horizontal Timing

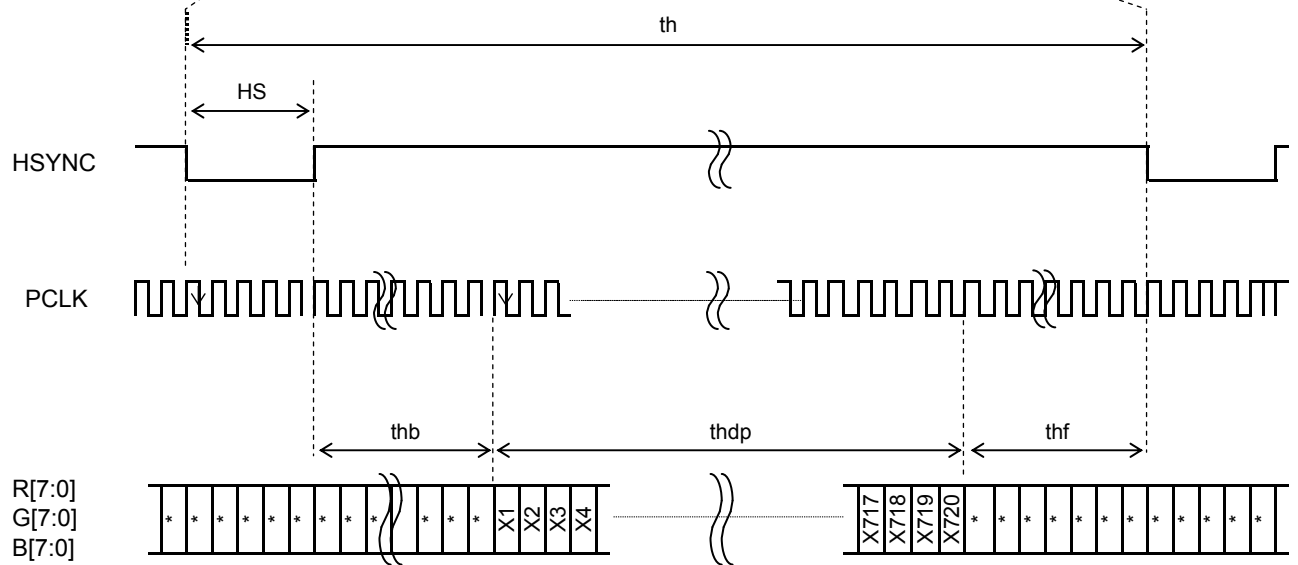

Timing Characteristics of input signals

8. About MIPI Interface

8.1 Version

The DSI incorporated in the LCD-Driver complies with the following standards.

MIPI DSI : Version 1.02

MIPI D-PHY : Version 1.00

Data transfer mode : Video mode only.

Virtual Channel : Set to VC[1:0]=00.

It is recommended to turn DSI_CLK off (LP 00) during the blanking period.

8.2 DSI protocol

- Short packets specify the payload length using the Data Type field and are from 2 to 9 bytes in length. Short packets is used for most Command Mode commands and associated parameters.

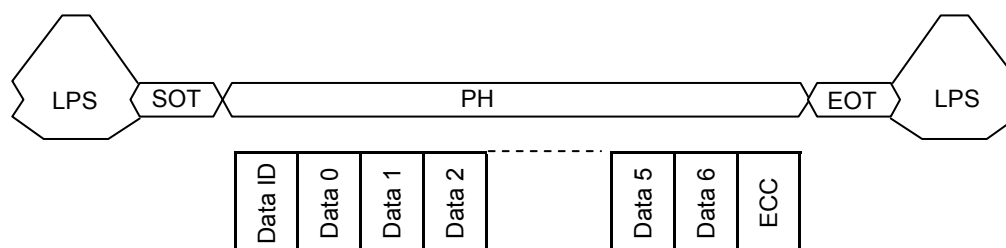

LPS : Low power state

SOT : Start of Transmission

PH : Packet Header

DI(Data ID) : Contain Virtual Channel Identifier and Data Type

ECC : Error Correction Code

- Long packets specify the payload length using a two-byte Word Count field and then the payload maybe 0 to 65,541 bytes in length. Long packets permit transmission of large blocks of pixel or other data.

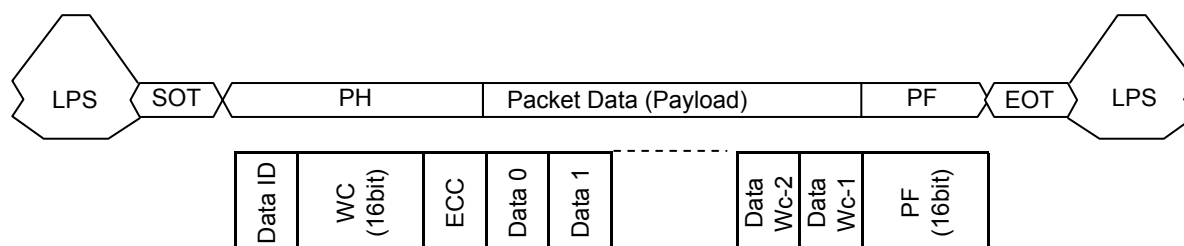

LPS : Low power state

SOT : Start of Transmission

PH : Packet Header

DI(Data ID) : Contain Virtual Channel Identifier and Data Type

WC(Word Count) : The receiver use WC to define packet end.

ECC : Error Correction Code

PF(Packet Footer) : Mean 16-bit Checksum.

8.3 Packet data types

LCD-Driver has the following restriction.

Generic short / Long Write Cmd is not supported.

It is only DCS Short / Long Write Cmd.

Processor to peripheral direction

Data Type Hex	Description	Size
01 h	Sync Event , V Sync Start (01,00,00,07)	Short
11 h	Sync Event , V Sync End (11,00,00,14)	Short
21 h	Sync Event , H Sync Start (21,00,00,12)	Short
31 h	Sync Event , H Sync End (31,00,00,01)	Short
22 h	Shut Down Peripheral Command (22,00,00,1E)	Short
32 h	Turn On Peripheral Command (32,00,00,0D)	Short
05 h	DCS WRITE , no parameters	Short
15 h	DCS WRITE , one parameters	Short
06 h	DCS READ , no parameters	Short
37 h	Set Maximum Return Packet Size	Short
08 h	End of Transmission Packet (08,0F,0F,01)	Short
09 h	Null Packet , no data	Long
19 h	Blanking Packet , no data	Long
39 h	DCS Long Write Command Packet	Long
0E h	Packed Pixel Stream , 16-bit RGB , 5-6-5 Format	Long
1E h	Packed Pixel Stream , 18-bit RGB , 6-6-6 Format	Long
2E h	Loosely Packed Pixel Stream , 18-bit RGB ,6-6-6 Format	Long
3E h	Packed Pixel Stream , 24-bit RGB , 8-8-8 Format	Long

Peripheral to processor direction

Data Type Hex	Description	Size
02 h	Acknowledge with Error Report	Short
1C h	DCS Long READ Response	Long

8.4 Packet Footer on the long packet

After Packet Data, Packet Footer is added in Long packet. Packet Footer adds CRC calculated from Packet Data as Checksum.

Checksum(2byte) = CRC(Packet Data)

$CRC = X^{16} + X^{12} + X^5 + X^0$

9.Sequence

PH :Packet Header

PD :Packet Data

PF:Packet Footer (=Checksum)

9.1 Power-ON Sequence

0		Function	DNC	Command /Parameter	Type	Command/Parameter
	Power on	VDD, VCCIO On				
	Wait	wait 1 msec or more				
	MIPI signal state	Keep CLKN/P, D0N/P, D1N/P D2N/P,D3N/P in STOP state LP-11 (Must be set to LP-11 is all lanes of MIPI before rising edge of RESX.)				
	H/W RESET	RESETB=1				
		RESETB=0 (Keep 20usec or more)				
		RESETB=1				
	Wait	wait 10 msec or more				
1	SETEXTC	Set extension command	0	B9h	PH	[39 04 00 2C]
		Parameter 1	1	FFh	PD	[B9 FF 83 94]
		Parameter 2	1	83h	PF	[XX XX]
		Parameter 3	1	94h		
2	SETPOWER	Set power	0	B1h	PH	[39, 11, 00, 33]
		Parameter 1	1	01h	PD	[B1 01 00 24 06 01 10 10 26 2E 1D 1D 57 12 01 E6 E2]
		Parameter 2	1	00h		
		Parameter 3	1	24h	PF	[XX XX]
		Parameter 4	1	06h		
		Parameter 5	1	01h		
		Parameter 6	1	10h		
		Parameter 7	1	10h		
		Parameter 8	1	26h		
		Parameter 9	1	2Eh		
		Parameter 10	1	1Dh		
		Parameter 11	1	1Dh		
		Parameter 12	1	57h		
		Parameter 13	1	12h		
		Parameter 14	1	01h		
		Parameter 15	1	E6h		
		Parameter 16	1	E2h		
3	SETDISP	Setdisp	0	B2h	PH	[39, 07, 00, 2A]
		Parameter 1	1	00h	PD	[B2 00 C8 04 04 00 66]
		Parameter 2	1	C8h		
		Parameter 3	1	04h	PF	[XX XX]
		Parameter 4	1	04h		
		Parameter 5	1	00h		
Parameter 6	1	66h				
4	INVOFF	Exit inversion mode	0	20h	PH	[05 20 00 23]
5	MADCTL	Set address mode	0	36h	PH	[15 36 00 29]
		Parameter 1	1	00h		
6	COLMOD	Set_pixel_format	0	3Ah	PH	[15 3A 70 28]
		Parameter 1(24bit/pixel)	1	70h		
7	SETCYC	Set display waveform cycle	0	B4h	PH	[39 1F 00 29]
		Parameter 1	1	00h	PD	[B4 00 04 32 10 00 32 10 00 32 10 08 27 01 53 03 37 01 53 01 30 30 01 01 43 01 43 01 61 61 01]
		Parameter 2	1	04h		
		Parameter 3	1	32h		
		Parameter 4	1	10h	PF	[XX XX]
		Parameter 5	1	00h		
		Parameter 6	1	32h		
		Parameter 7	1	10h		
		Parameter 8	1	00h		
		Parameter 9	1	32h		
		Parameter 10	1	10h		
		Parameter 11	1	08h		
		Parameter 12	1	27h		
		Parameter 13	1	01h		
		Parameter 14	1	53h		
		Parameter 15	1	03h		
		Parameter 16	1	37h		
		Parameter 17	1	01h		
		Parameter 18	1	53h		

△D

No.	Function	DNC	Command /Parameter	Type	Command/Parameter
	Parameter 19	1	01h		
	Parameter 20	1	30h		
	Parameter 21	1	30h		
	Parameter 22	1	01h		
	Parameter 23	1	01h		
	Parameter 24	1	43h		
	Parameter 25	1	01h		
	Parameter 26	1	43h		
	Parameter 27	1	01h		
	Parameter 28	1	61h		
	Parameter 29	1	61h		
	Parameter 30	1	01h		
8	Not open	0	BFh	PH	[39, 05, 00, 36]
		1	06h	PD	[BF 06 02 00 04]
		1	02h	PF	[XX XX]
		1	04h		
9	Not open	0	C7h	PH	[39, 05, 00, 36]
		1	00h	PD	[C7 00 10 00 10]
		1	10h	PF	[XX XX]
		1	10h		
10	Not open	0	C6h	PH	[39, 03, 00, 09]
		1	08h	PD	[C6 08 08]
		1	08h	PF	[XX XX]
11	Not open	0	C0h	PH	[39, 03, 00, 09]
		1	0Ch	PD	[C0 0C 15]
		1	15h	PF	[XX XX]
12	SETGIP	0	D5h	PH	[39 21 00 3C]
		1	00h	PD	[D5 00 00 00 00 0A 00 01 33 00 00
		1	00h	PD	33 00 10 32 54 76 10 32 88 88 88 88
		1	00h	PD	88 88 88 99 99 99 54 76 88 88]
		1	00h	PF	[XX XX]
		1	0Ah		
		1	00h		
		1	01h		
		1	33h		
		1	00h		
		1	00h		
		1	33h		
		1	00h		
		1	10h		
		1	32h		
		1	54h		
		1	76h		
		1	10h		
		1	32h		
		1	88h		
		1	88h		
		1	88h		
		1	88h		
		1	88h		
		1	88h		
		1	99h		
		1	99h		
		1	99h		
		1	54h		
		1	76h		
		1	88h		
		1	88h		

No.	Function	DNC	Command /Parameter	Type	Command/Parameter	
13	SETDGC	Set Digital Gamma Correction setting	0	C1h	PH	[39 80 00 23]
		Parameter 1	1	01h	PD	[C1 01 00 06 0E 16 1E 26 2E 36 3E 46 4E 56 5E 66 6E 76 7E 86 8E 96 9E A6 AE B6 BE C6 CE D6 DE E6 EE F6 FE 00 00 00 00 00 00 00 00 00 03 0B 13 1B 23 2B 33 3B 43 4B 53 5B 63 6B 73 7B 83 8B 93 9B A3 AB B3 BB C3 CB D3 DB E3 EB F3 FB 00 00 00 00 00 00 00 00 00 00 08 10 18 1E 26 2E 36 3E 46 4E 56 5E 66 6E 76 7E 86 8E 96 9E A6AE B6 BE C6CE D6 DE E6 ED F5 00 00 00 00 00 00 00 00 00]
		Parameter 2	1	00h		
		Parameter 3	1	06h		
		Parameter 4	1	0Eh		
		Parameter 5	1	16h		
		Parameter 6	1	1Eh		
		Parameter 7	1	26h		
		Parameter 8	1	2Eh		
		Parameter 9	1	36h		
		Parameter 10	1	3Eh		
		Parameter 11	1	46h		
		Parameter 12	1	4Eh		
		Parameter 13	1	56h		
		Parameter 14	1	5Eh		
		Parameter 15	1	66h		
		Parameter 16	1	6Eh	PF	[XX XX]
		Parameter 17	1	76h		
		Parameter 18	1	7Eh		
		Parameter 19	1	86h		
		Parameter 20	1	8Eh		
		Parameter 21	1	96h		
		Parameter 22	1	9Eh		
		Parameter 23	1	A6h		
		Parameter 24	1	AEh		
		Parameter 25	1	B6h		
		Parameter 26	1	BEh		
		Parameter 27	1	C6h		
		Parameter 28	1	CEh		
		Parameter 29	1	D6h		
		Parameter 30	1	DEh		
		Parameter 31	1	E6h		
		Parameter 32	1	EEh		
		Parameter 33	1	F6h		
		Parameter 34	1	FEh		
		Parameter 35	1	00h		
		Parameter 36	1	00h		
		Parameter 37	1	00h		
		Parameter 38	1	00h		
		Parameter 39	1	00h		
		Parameter 40	1	00h		
		Parameter 41	1	00h		
		Parameter 42	1	00h		
		Parameter 43	1	00h		
		Parameter 44	1	00h		
		Parameter 45	1	03h		
		Parameter 46	1	0Bh		
		Parameter 47	1	13h		
		Parameter 48	1	1Bh		
		Parameter 49	1	23h		
		Parameter 50	1	2Bh		
		Parameter 51	1	33h		
		Parameter 52	1	3Bh		
		Parameter 53	1	43h		
		Parameter 54	1	4Bh		
		Parameter 55	1	53h		
		Parameter 56	1	5Bh		
		Parameter 57	1	63h		
		Parameter 58	1	6Bh		
		Parameter 59	1	73h		
		Parameter 60	1	7Bh		
Parameter 61	1	83h				

No.	Function	DNC	Command /Parameter	Type	Command/Parameter
	Parameter 62	1	8Bh		
	Parameter 63	1	93h		
	Parameter 64	1	9Bh		
	Parameter 65	1	A3h		
	Parameter 66	1	ABh		
	Parameter 67	1	B3h		
	Parameter 68	1	BBh		
	Parameter 69	1	C3h		
	Parameter 70	1	CBh		
	Parameter 71	1	D3h		
	Parameter 72	1	DBh		
	Parameter 73	1	E3h		
	Parameter 74	1	EBh		
	Parameter 75	1	F3h		
	Parameter 76	1	FBh		
	Parameter 77	1	00h		
	Parameter 78	1	00h		
	Parameter 79	1	00h		
	Parameter 80	1	00h		
	Parameter 81	1	00h		
	Parameter 82	1	00h		
	Parameter 83	1	00h		
	Parameter 84	1	00h		
	Parameter 85	1	00h		
	Parameter 86	1	00h		
	Parameter 87	1	00h		
	Parameter 88	1	08h		
	Parameter 89	1	10h		
	Parameter 90	1	18h		
	Parameter 91	1	1Eh		
	Parameter 92	1	26h		
	Parameter 93	1	2Eh		
	Parameter 94	1	36h		
	Parameter 95	1	3Eh		
	Parameter 96	1	46h		
	Parameter 97	1	4Eh		
	Parameter 98	1	56h		
	Parameter 99	1	5Eh		
	Parameter 100	1	66h		
	Parameter 101	1	6Eh		
	Parameter 102	1	76h		
	Parameter 103	1	7Eh		
	Parameter 104	1	86h		
	Parameter 105	1	8Eh		
	Parameter 106	1	96h		
	Parameter 107	1	9Eh		
	Parameter 108	1	A6h		
	Parameter 109	1	AEh		
	Parameter 110	1	B6h		
	Parameter 111	1	BEh		
	Parameter 112	1	C6h		
	Parameter 113	1	CEh		
	Parameter 114	1	D6h		
	Parameter 115	1	DEh		
	Parameter 116	1	E6h		
	Parameter 117	1	EDh		
	Parameter 118	1	F5h		
	Parameter 119	1	00h		
	Parameter 120	1	00h		
	Parameter 121	1	00h		
	Parameter 122	1	00h		
	Parameter 123	1	00h		
	Parameter 124	1	00h		
	Parameter 125	1	00h		
	Parameter 126	1	00h		
	Parameter 127	1	00h		

No.	Function	DNC	Command /Parameter	Type	Command/Parameter	
14	SETGAMMA	Set gamma curve related setting	0	E0h	PH	[39 2B 00 05]
		Parameter 1	1	00h	PD	[E0 00 00 00 12 1D 34 13 2A 04 0C 12 16 19 16 16 0E 11 00 00 00 18 24 3F 16 2C 04 0D 10 16 18 16 16 10 11 07 16 06 0F 08 16 07 10]
		Parameter 2	1	00h		
		Parameter 3	1	00h	PF	[XX XX]
		Parameter 4	1	12h		
		Parameter 5	1	1Dh		
		Parameter 6	1	34h		
		Parameter 7	1	13h		
		Parameter 8	1	2Ah		
		Parameter 9	1	04h		
		Parameter 10	1	0Ch		
		Parameter 11	1	12h		
		Parameter 12	1	16h		
		Parameter 13	1	19h		
		Parameter 14	1	16h		
		Parameter 15	1	16h		
		Parameter 16	1	0Eh		
		Parameter 17	1	11h		
		Parameter 18	1	00h		
		Parameter 19	1	00h		
		Parameter 20	1	00h		
		Parameter 21	1	18h		
		Parameter 22	1	24h		
		Parameter 23	1	3Fh		
		Parameter 24	1	16h		
		Parameter 25	1	2Ch		
		Parameter 26	1	04h		
		Parameter 27	1	0Dh		
		Parameter 28	1	10h		
		Parameter 29	1	16h		
		Parameter 30	1	18h		
		Parameter 31	1	16h		
		Parameter 32	1	16h		
		Parameter 33	1	10h		
		Parameter 34	1	11h		
		Parameter 35	1	07h		
		Parameter 36	1	16h		
		Parameter 37	1	06h		
		Parameter 38	1	0Fh		
		Parameter 39	1	08h		
		Parameter 40	1	16h		
		Parameter 41	1	07h		
Parameter 42	1	10h				
15	SETCABC	Set CABC Control (PWM=35kHz)	0	C9h	PH	[39 0A 00 36]
		Parameter 1	1	0Fh	PD	[C9 0F 00 1E 1E 00 00 00 01 3E]
		Parameter 2	1	00h		
		Parameter 3	1	1Eh	PF	[XX XX]
		Parameter 4	1	1Eh		
		Parameter 5	1	00h		
		Parameter 6	1	00h		
		Parameter 7	1	00h		
		Parameter 8	1	01h		
Parameter 9	1	3Eh				
16	WRDISBV	Write display brightness	0	51h	PH	[15 51 FF 3C]
		Parameter 1(255/255)	1	FFh		
17	WRCTRLD	Write CTRL display(PWM OFF)	0	53h	PH	[15 53 00 13]
		Parameter 1	1	00h		
18	SETVDC	SETVDC	0	BCh	PH	[15 BC 07 0B]
		Parameter 1	1	07h		
	Wait	wait 5 msec or more				
19	SETPANEL	Set panel	0	CCh	PH	[15 CC 09 10]
		Parameter 1	1	09h		
	Wait	wait 50 msec or more				
20	SETMIPI	Set MIPI control	0	BAh	PH	[15 BA 03 00]
		Parameter 1(4 lane)	1	03h		
21	SLEEP OUT	Sleep out	0	11h	PH	[05 11 00 36]
		Wait	wait 200 msec or more			
22	DISPON	Display on	1	29h	PH	[05 29 00 1C]
		Wait	wait 50 msec or more			
23	Video stream					

PH :Packet Header
PD :Packet Data
PF:Packet Footer (=Checksum)

9.2 Power-OFF Sequence

No.	Function	DNC	Command /Parameter	Type	Command/Parameter
1	DISPOFF	0	28h	PH	[05 28 00 06]
2	SLPIN	0	10h	PH	[05 10 00 2C]
	Wait				
3	Video signals				
4	RESETB				

Power off

9.3 Sleep Sequence

No.	Function	DNC	Command /Parameter	Type	Command/Parameter
1	SLPIN	0	10h	PH	[05 10 00 2C]
	Wait				
2	Video signals				

9.4 Sleep Release Sequence

No.	Function	DNC	Command /Parameter	Type	Command/Parameter
1	Video signals				
	Wait				
2	SLPOUT	0	11h	PH	[05 11 00 36]

9.5 ULPS (Ultra-low power state) Enter/Exit Sequence

Lane	Mode	Sequence
D0P,D0N	Enter ULPS	LP11 → LP10 → LP00 → LP01 → LP00 → (78h) → LP00(ULPS)
	Exit ULPS	LP10 (keeps for at least 1 ms) → LP11
CP,CN	Enter ULPS	LP11 → LP10 → LP00(ULPS)
	Exit ULPS	LP10 (keeps for at least 1 ms) → LP11

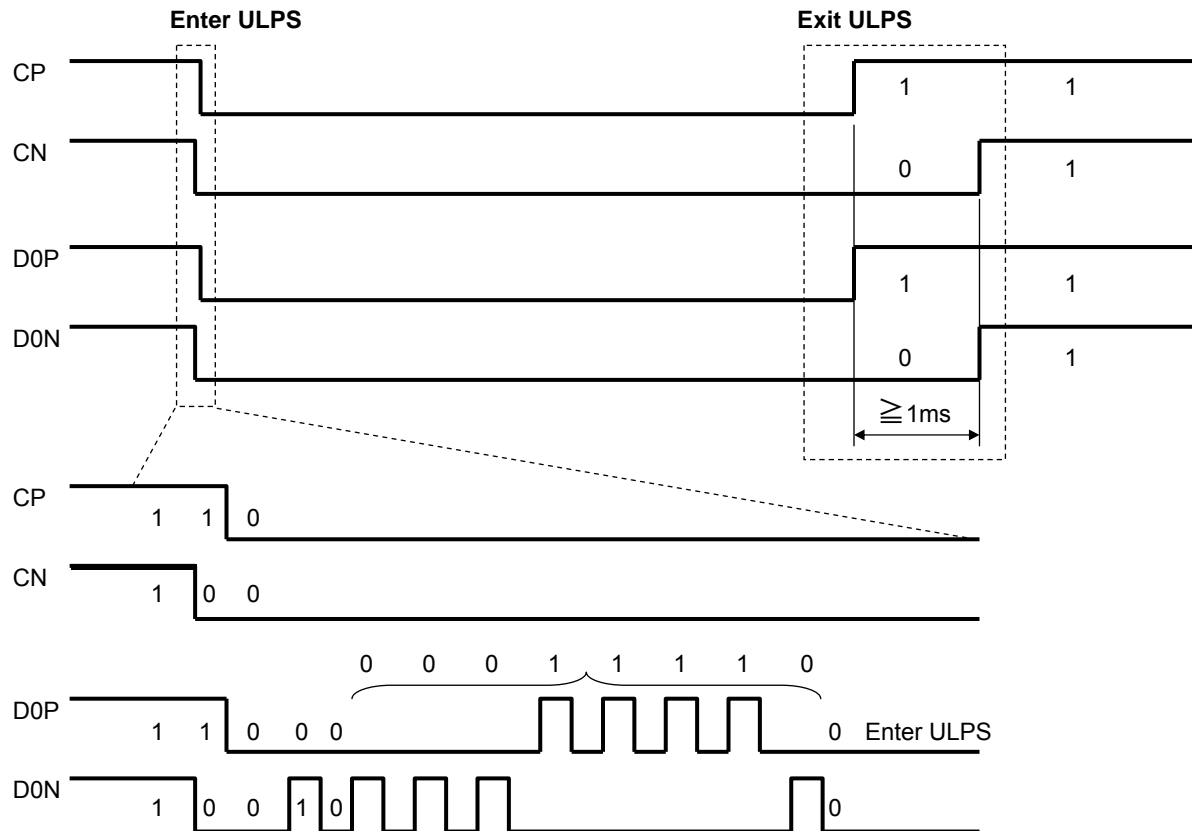

9.6. External Power on/off Sequence

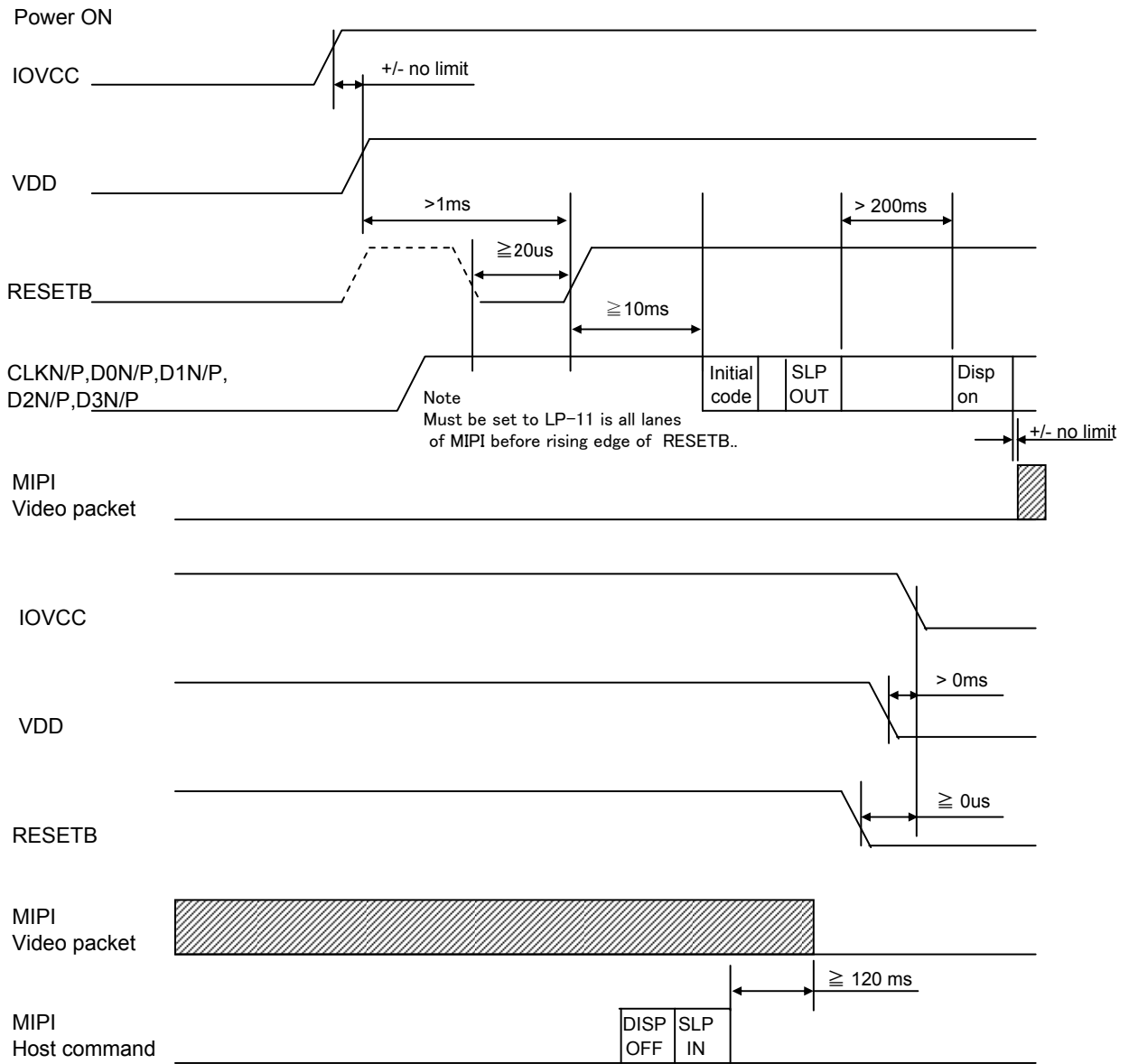

10. CABC: Content adaptive brightness control function

10.1 CABC Block diagram

The general block diagram of the CABC and the brightness control is illustrated below:

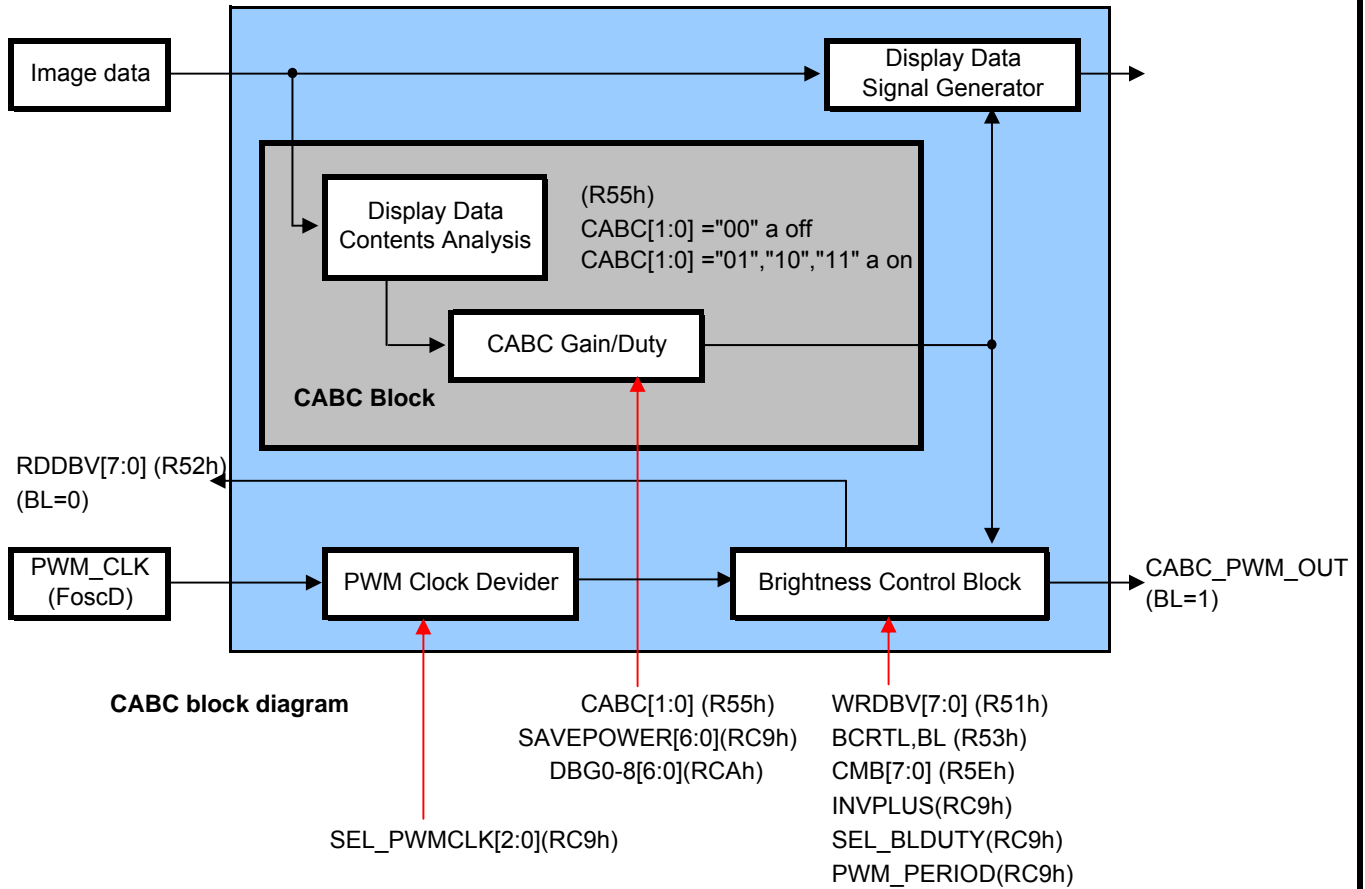

10.2 CABC Block

There are register bits,DBG0-8[6:0] of RCAh, in CABC block to define the "CABC gain/CABC duty" table.

Every DBGx[6:0] has 33 gain/duty value setting

After one-frame display data content analysis,LSI will generate one CABC gain / CABC duty value calculated from DBG0-8[6:0] register bit setting(by using interpolated method) for display data generating and for backlight PWM pulse generating.

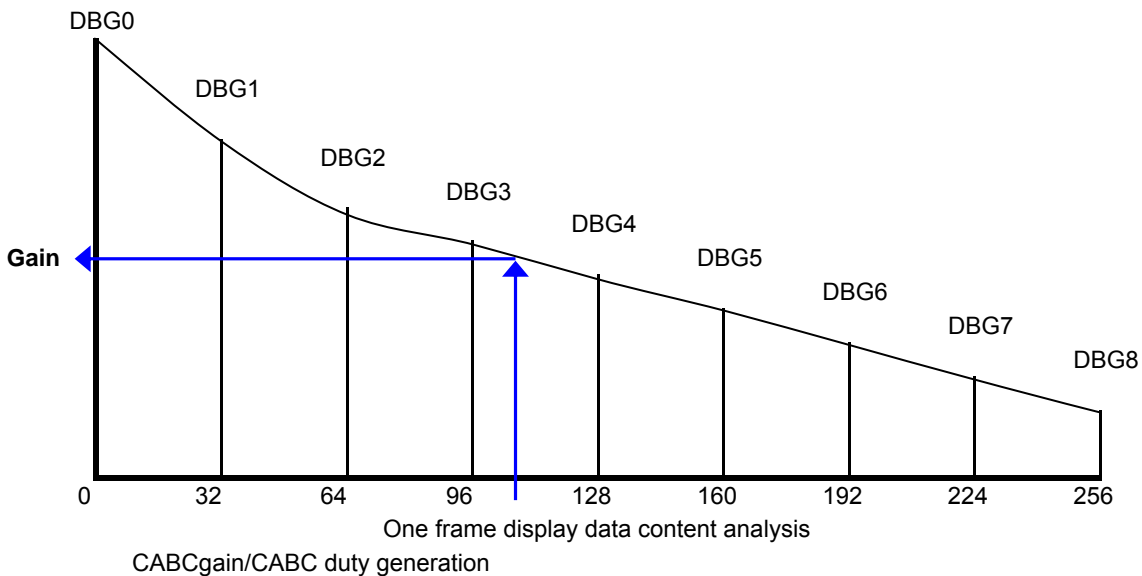

10.3 Brightness control block

There is an external output signal from brightness block, CABC_PWM_OUT, to control the LED driver IC in order to control display brightness.

There are register bits, DBV[7:0] of R51h, for display brightness of manual brightness setting.

The CABC_PWM_OUT duty is calculated as $(DBV[7:0]/255) \times \text{CABC duty}$ (generated after one-frame display data content analysis).

10.4 Minimum brightness setting of CABC function

CABC function is automatically reduced backlight brightness based on image contents.

In the case of the combination with the CABC or manual brightness setting, display brightness is too dark.

It must affect to image quality degradation.

CABC minimum brightness setting (CMB[7:0] bits of R5Eh) is to avoid too much brightness reduction.

When CABC is active, CABC can not reduce the display brightness to less than CABC minimum brightness setting.

Image processing function is worked as normal, even if the brightness can not be changed.

10.5 CABC command list

Command

(Hex)	Register	DCX	D7	D6	D5	D4	D3	D2	D1	D0		
51h	WRDISBV	0	0	1	0	1	0	0	0	1		
		1	DBV[7:0]									
53h	WRCTRLD	0	0	1	0	1	0	0	1	1		
		1	-	-	BCTRL	-	DD	BL	-	-		
55h	WRCABC	0	0	1	0	1	0	1	0	1		
		1	-	-	-	-	-	-	CABC[1:0]			
5Eh	WRCABCMB	0	0	1	0	1	1	1	1	0		
		1	CMB[7:0]									
C9h	SETCABC	0	1	1	0	0	1	0	0	1		
		1	-	SEL_PWMCLK[2:0]			SEL_GAIN[1:0]		INVPULS	SEL_BL DUTY		
		1	PWM_PERIOD[7:0]									
		1	CABC_F SYNC	DIM_FRAME[6:0]								
		1	CABC_STEP[7:0]									
		1	CABC_CLKEN[7:0]									
		1	CABC_D D	SAVEPOWER[6:0]								
		1	MEAN_OFFSET[7:0]									
		1	-	-	-	-	CABC_FLM[3:0]					
		1	-	-	EN_DIM MIX	EN_CO ST_ME	EN_CO ST	EN_NLN _GAIN	EN_JUD GE	EN_TEM P		
		1	RATIO_VAQLUE[3:0]				DATAG AIN_EN		RATIO_ EN	DATAGAIN[9:8]		
		1	DATAGAIN[7:0]									
CAh	SETCABC GAIN	0	1	1	0	0	1	0	1	0		
		1	DBG0-8[6:0] 1-9th parameter									

• Command 51h (WRDISBV)

This command is used to adjust the brightness value of the display.

The CABC_PWM_OUT duty is calculated as $(DBV[7:0]/255) \times \text{CABC duty}$

- Command 53h (WRCTRLD)

This command is used to control display brightness.

BCTRL: Brightness Control Block On/Off, This bit is always used to switch brightness for display.

0 = Off (Brightness registers are 00h, DBV[7..0])

1 = On (Brightness registers are active, according to the other parameters.)

Display Dimming (DD): (Only for manual brightness setting)

DD = 0: Display Dimming is off DD = 1: Display Dimming is on

BL: Backlight Control On/Off

0 = Off (Completely turn off backlight circuit. Control lines must be low.) 1 = On

- Command 55h (WRCABC)

This command is used to set parameters for image content based adaptive brightness control functionality.

There is possible to use 4 different modes for content adaptive image functionality.

Which are defined on a table below.

D1	D0	Function
0	0	Off
0	1	User Interface Image
1	0	Still Picture
1	1	Moving Image

- Command 5Eh (WRCABCMB)

This command is used to set the minimum brightness value of the display for CABC function.

In principle relationship is that 00h value means the lowest brightness for CABC and FFh value means the highest brightness for CABC.

- Command C9h(SETCABC)

SEL_PWMCLK[2:0]	Internal PWM_CLK divider for CABC clock.
SEL_GAIN	CABC gain select
INPULS	0=PWM output is low level active. 1= High level active
SEL_BLDUTY	0=PWM output duty is 100% 1= Duty is calculate CABC operation
PWM_PERIOD[7:0]	PWM output period setting.
CABC_FSYNC DIM_FRAME[7:0] CABC_STEP[7:0] CABC_CLKEN[7:0]	In-house function,and not open
CABC_DD	0=Disable CABC dimming. 1=Enable CABC dimming.
SAVEPOWER	Minimum CABC gain / maximum CABC duty output select.

- Command CAh(SETCABC GAIN)

DBG0-8[6:0]: Gain select register.

Refer to "10.2 CABC_Block".

11. LED Circuit

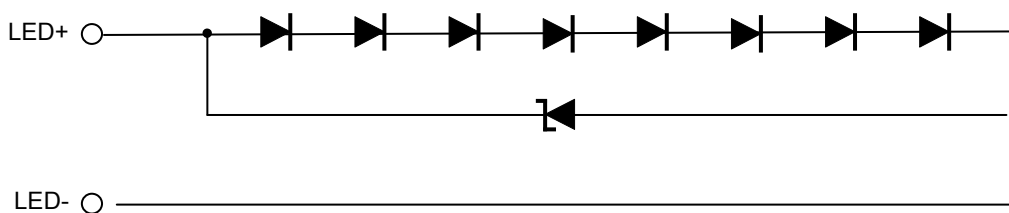

12. Characteristics

12.1 Optical Characteristics

< Measurement Condition >



Measuring instruments: CS2000 (KONICA MINOLTA), LCD7200 (OTSUKA ELECTRONICS),
EZcontrast160D (ELDIM)

Driving condition: VDD = 2.9V, VCCIO = 1.9V, GND=0V
Optimized VCOMDC

Backlight: IL=10.0mA

Measured temperature: Ta=25° C

Item	Symbol	Condition	MIN	TYP	MAX	Unit	Note No.	Remark
Response time	Rise time	TON	[Data]= 00h→FFh	—	—	60	ms	1
	Fall time	TOFF	[Data]= FFh→00h	—	—	40	ms	
Contrast ratio	Backlight ON	CR	[Data]= FFh / 00h	400	800	—		2
	Backlight OFF			—	3	—		
Viewing angle	Left	θL	[Data]= FFh / 00h CR ≥ 10	80	—	—	deg	3
	Right	θR		80	—	—	deg	
	Up	φU		80	—	—	deg	
	Down	φD		80	—	—	deg	
White Chromaticity	x		White chromaticity range				4	
	y							
Burn-in			No noticeable burn-in image shall be observed after 2 hours of window pattern display.				5	
Center brightness		[Data]=FFh	260	400	—	cd/m ²	6	
Brightness distribution		[Data]=FFh	70	—	—	%	7	

* Note number 1 to 7: Refer to the APPENDIX of "Reference Method for Measuring Optical Characteristics".

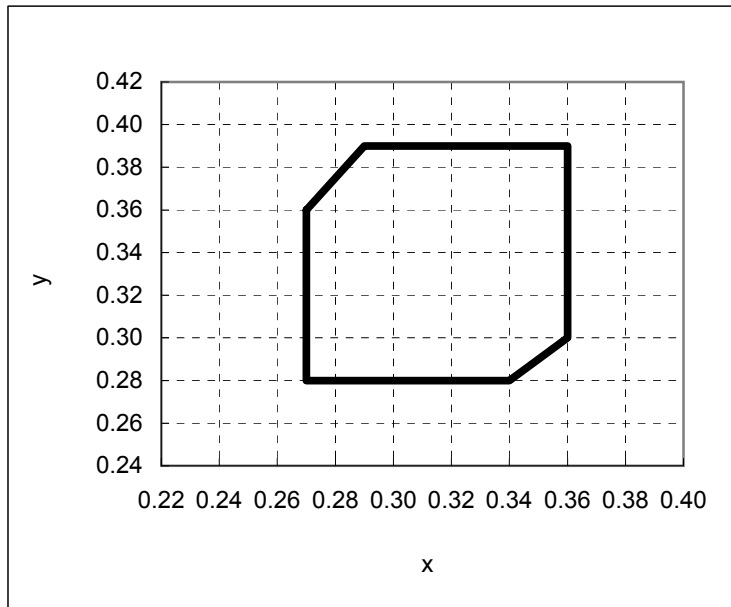

White Chromaticity Range

【White Chromaticity Range】

x	y
0.27	0.36
0.27	0.28
0.34	0.28
0.36	0.30
0.36	0.39
0.29	0.39

12.2 Temperature Characteristics

< Measurement Condition >



Measuring instruments: CS2000 (KONICA MINOLTA), LCD7200(OTSUKA ELECTRONICS)

Driving condition: VDD = 2.9V, VCCIO = 1.9V, GND=0V

Optimized VCOMDC

Backlight: IL=10.0mA

Item			Specification		Remark
			Ta=-20°C	Ta=70°C	
Contrast ratio		CR	200 or more	200 or more	Backlight ON
Response time	Rise time	TON	300 msec or less	50 msec or less	
	Fall time	TOFF	300 msec or less	30 msec or less	
Display Quality			No noticeable display defect or nonuniformity should be observed.		

13. Criteria of Judgment

13.1 Defective Display and Screen Quality

Test Condition: Observed TFT-LCD monitor from front during operation with the following conditions

Driving Signal Raster Patter (RGB, white, black)

Signal condition [Data]:00h, 9Dh, FFh (3steps)

Observation distance 30 cm

Illuminance 200 to 350 lx

Backlight IL=10.0mA

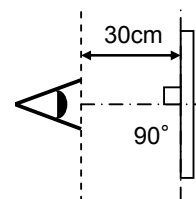

Defect item	Defect content	Criteria		
Display Quality	Line defect	Black, white or color line, 3 or more neighboring defective dots	Not exists	
	Dot defect	Uneven brightness on dot-by-dot base due to defective TFT or CF, or dust is counted as dot defect (brighter dot, darker dot)	Refer to table 1	
		High bright dot: Visible through 2% ND filter at [Data]=00h	Acceptable	
		Low bright dot: Visible through 5% ND filter at [Data]=00h		
	Dark dot: Appear dark through white display at [Data]=9Dh			
		Invisible through 5% ND filter at [Data]=(00)h		
Screen Quality	Dirt	Uneven brightness (white stain, black stain etc)	Invisible through 5% ND filter at Black screen. Invisible through 1% ND filter at other screen.	
	Foreign particle	Point-like	$0.25\text{mm} < \varphi$	N=0
			$0.20\text{mm} < \varphi \leq 0.25\text{mm}$	$N \leq 2$
			$\varphi \leq 0.20\text{mm}$	Acceptable
	Liner		$3.0\text{mm} < \text{length and } 0.08\text{mm} < \text{width}$	N=0
			$\text{length} \leq 3.0\text{mm or width} \leq 0.08\text{mm}$	Acceptable
Others			Use boundary sample for judgment when necessary	

$\varphi(\text{mm})$: Average diameter = (major axis + minor axis)/2
Permissible number: N

Table 1

Area	High bright dot	Low bright dot	Dark dot	Total	Criteria
A	0	2	2	3	Permissible distance between same color bright dots (includes neighboring dots): 3 mm or more Permissible distance between same color high bright dots (includes neighboring dots): 5 mm or more
B	2	4	4	6	
Total	2	4	4	7	

<Portrait model>

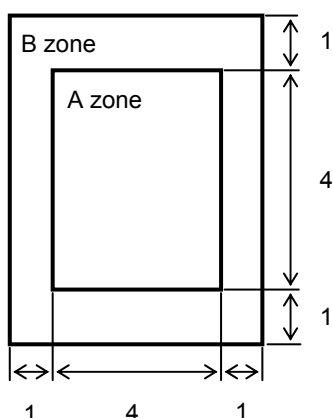

Division of A and B areas

B area: Active area
Dimensional ratio between A and B areas: 1: 4: 1
(Refer to the left figure)

13.2 Screen and Other Appearance

Testing conditions

Observation distance	30cm
Illuminance	1200~2000 lx

Item	Criteria	Remark
Polarizer Flaw Stain Bubble Dust Dent	Ignore invisible defect when the backlight is on.	Applicable area: Active area only (Refer to the section 3.2 "Outward form")
S-case	No functional defect occurs	
FPC cable	No functional defect occurs	

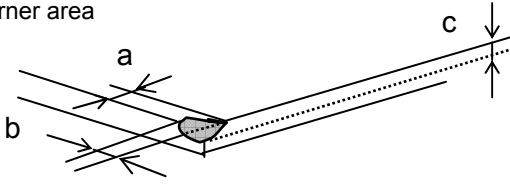
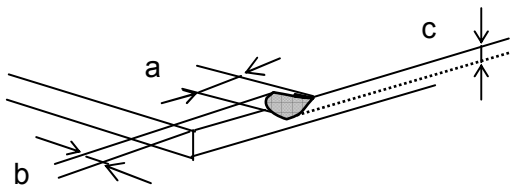
Item	Appearance	Criteria
Glass chipping	Corner area 	Unit:mm $a \leq 3$ $b \leq 3$ $c \leq t$ (t: glass thickness) $a, b \leq 0.5$ is acceptable Maximum permissible number of chipping off on a side is 2.
	Others 	Unit:mm $a \leq 5$ $b \leq 1$ $c \leq t$ (t:glass thickness) $a, b \leq 0.5$ is acceptable Maximum permissible number of chipping off on a side is 5.
	Progressive crack	None

14. Reliability Test

Test item		Test condition		number of failures /number of examinations
Durability test	High temperature storage	Ta=80° C	240hrs	0/3
	Low temperature storage	Ta=-30° C	240hrs	0/3
	High temperature & high humidity storage	Ta=60° C, RH=90% non condensing	240hrs	0/3
	High temperature operation	Tp=70° C	240hrs	0/3
	Low temperature operation	Tp=-20° C	240hrs	0/3
	High temp & humid operation	Tp=40° C, RH=90% non condensing	240hrs	0/3
	Thermal shock storage	-30↔80° C(30min/30min)	100 cycles	0/3
	Lightfastness	Xenon Blackpanel 63±3° C non-shower 450W/m ² (300~700nm) non-operating Integral dose 800MJ/m ²		0/3
Mechanical environmental test	Electrostatic discharge test (Non operation)	Confirms to EIAJ ED-4701/300 C=200pF,R=0Ω,V=±200V Each 3 times of discharge on and power supply and other terminals.		0/3
	Surface discharge test (Non operation)	C=250pF, R=100Ω, V=±12kV Each 5 times of discharge in both polarities on the center of screen with the case grounded.		0/3
	FPC tension test	Pull the FPC with the force of 3N for 10 sec. in the direction - 90-degree to its original direction.		0/3
	FPC bend test	Pull the FPC with the force of 3N for 10 sec. in the direction -180-degree to its original direction. Reciprocate it 3 times.		0/3
	Vibration test	Total amplitude 1.5mm, f=10~55Hz, X,Y,Z directions for each 2 hours		0/3
	Impact test	Use TOPPAN PRINTING original jig (see next page)and make an impact with peak acceleration of 1000m/s ² for 6 msec with half sine-curve at 3 times to each X, Y, Z directions in conformance with JIS C 60068-2-27-2011.		0/3
Packing test	Packing vibration-proof test	Acceleration of 19.6m/s ² with frequency of 10→55→10Hz, X,Y, Zdirection for each 30 minutes		0/1 Packing
	Packing drop test	Drop from 75cm high. 1 time to each 6 surfaces, 3 edges, 1 corner		0/1 Packing

Note: Ta=ambient temperature Tp=Panel temperature

※ The profile of high temperature/humidity storage and High Temperature/humidity operation
(Pure water of over 10MΩ·cm shall be used.)

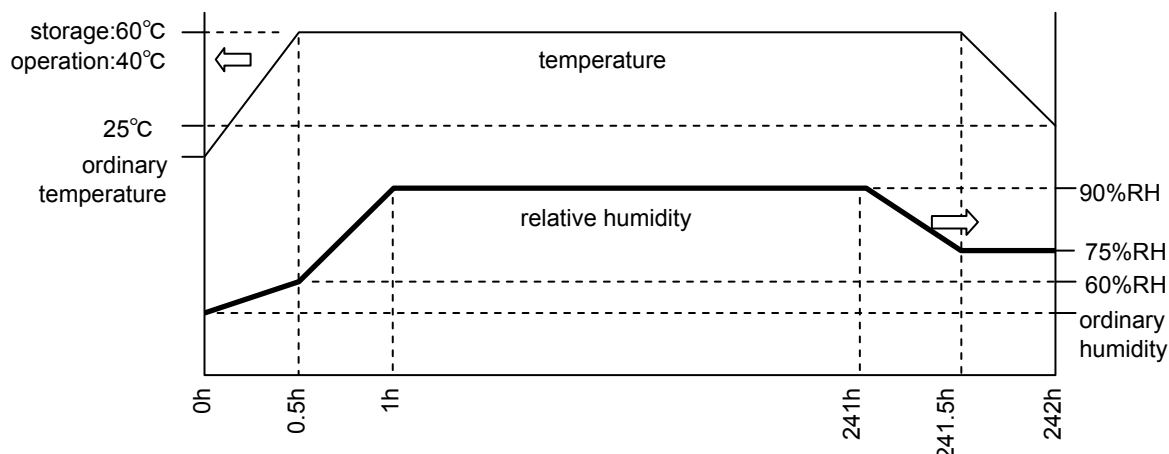
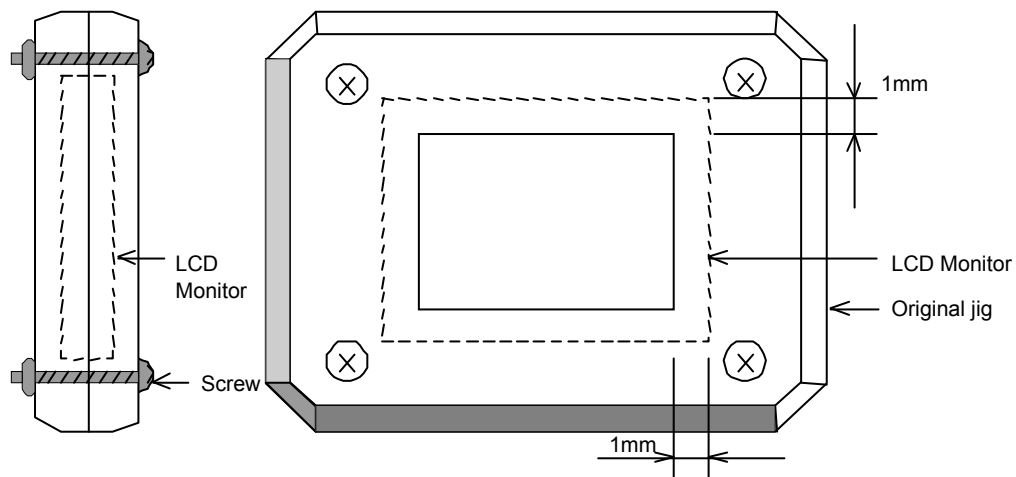

Table2.Reliability Criteria

The parameters should be measured after leaving the monitor at the ordinary temperature for 24 hours or more after the test completion.

item	Standard	Remarks
Display quality	No visible abnormality shall be seen. (Except for unevenness by PoI deterioration.)	
Contrast ratio	200 or more	Backlight ON

TOPPAN PRINTING Original Jig



Tension Test Method for FPC cable

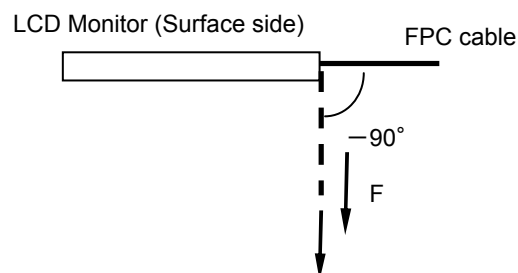

Bend Test Method for FPC cable

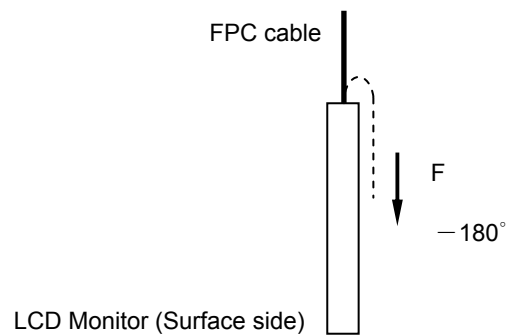

15. Packing Specifications

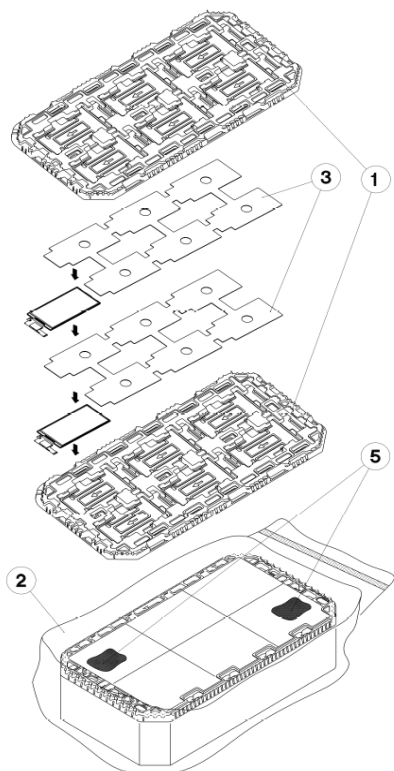

Step1. Each product is to be placed in one of the cut-outs of the tray with the display surface facing upward. (6products per tray)
Foam sheet is to be placed on the products in the tray.
Each product is to be placed in one of the cut-outs of the tray with the display surface facing upward. (12products per tray)
Foam sheet is to be placed on the products in the tray.

Step2. •Each tray needs to be stacked with 180 degrees alternate to the tray under or over it and the trays be in a stack of 8.
•One empty tray is to be put on the top of stack of 8 packed trays.
When overlaying the tray, change the direction of 180 °.

Step3. 2 packs of moisture absorbers are to be placed on the top tray as shown in the drawing.
Put piled trays into a sealing bag.

Step4. Vacuum and seal the sealing bag with the vacuum sealing machine.

Step5. The stack of trays in the sealing bag is to be wrapped with a bubble cushioning sheet.

Step6. The wrapped trays are placed in the outer carton.

Step7. Bubble cushioning sheets are to be inserted into the outer carton with same orientation.
The outer carton is to be sealed in H-shape with packing tape as shown in the drawing.

Step8. The model number, quantity of products, and shipping date are to be printed on the outer carton.
If necessary, shipping labels or impression markings are to be put on the outer carton.

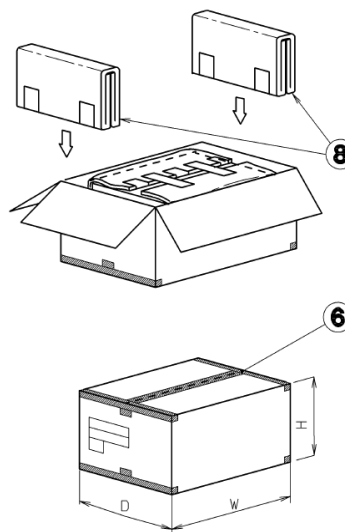
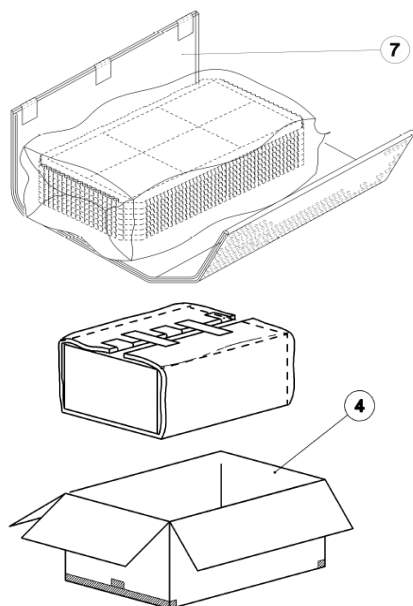

Remark: The return of packing materials is not required.

	Packing item name	Specs., Material
①	Tray	A-PET
②	Sealing bag	
③	FOAM SHEET	Anti-static polyethylene
④	Outer carton	Corrugated cardboard
⑤	Drier	Moisture absorber
⑥	Packing tape	
⑦	B SHEET A	Anti-static air babbie sheet
⑧	B SHEET B	Anti-static air babbie sheet

Dimension of extra outer carton	
D : Approx.	(337mm)
W : Approx.	(618mm)
H : Approx.	(179mm)
Quantity of products packed in one carton:	96
Gross weight : Approx.	6.0Kg

16. Handling Instruction

16.1 Cautions for Handling LCD panels

**Caution**

- (1) Do not make an impact on the LCD panel glass because it may break and you may get injured from it.
- (2) If the glass breaks, do not touch it with bare hands.
(Fragment of broken glass may stick you or you cut yourself on it.)
- (3) If you get injured, receive adequate first aid and consult a medial doctor.
- (4) Do not let liquid crystal get into your mouth.
(If the LCD panel glass breaks, try not let liquid crystal get into your mouth even toxic property of liquid crystal has not been confirmed.)
- (5) If liquid crystal adheres, rinse it out thoroughly.
(If liquid crystal adheres to your cloth or skin, wipe it off with rubbing alcohol or wash it thoroughly with soap. If liquid crystal gets into eyes, rinse it with clean water for at least 15 minutes and consult an eye doctor.)
- (6) If you scrap this products, follow a disposal standard of industrial waste that is legally valid in the community, country or territory where you reside.
- (7) Do not connect or disconnect this product while its application products is powered on.
- (8) Do not attempt to disassemble or modify this product as it is precision component.
- (9) If a part of soldering part has been exposed, and avoid contact (short-circuit) with a metallic part of the case etc. about FPC of this model, please.
Please insulate it with the insulating tape etc. if necessary.
The defective operation is caused, and there is a possibility to generation of heat and the ignition.
- (10) Since excess current protection circuit is not built in this TFT module, there is the possibility that LCD module or peripheral circuit become feverish and burned in case abnormal operation is generated.
We recommend you to add excess current protection circuit to power supply.
- (11) The devices on the FPC are damageable to electrostatic discharge, because the terminals of the devices are exposed.
Wear grounded wrist-straps and use electrostatic neutralization blowers to prevent static charge and discharge when handling the TFT monitors.
Designate an appropriate operating area, and set equipment, tools, and machines properly when handling this product.



Caution This mark is used to indicate a precaution or an instruction which, if not correctly observed, may result in bodily injury, or material damages alone.

16.2 Precautions for Handling

- 1) Wear finger tips at incoming inspection and for handling the TFT monitors to keep display quality and keep the working area clean.
Do not touch the surface of the monitor as it is easily scratched.
- 2) Wear grounded wrist-straps and use electrostatic neutralization blowers to prevent static charge and discharge when handling the TFT monitors as the LED in this TFT monitors is damageable to electrostatic discharge. Designate an appropriate operating area, and set equipment, tools, and machines properly when handling this product.
- 3) Avoid strong mechanical shock including knocking, hitting or dropping to the TFT monitors for protecting their glass parts. Do not use the TFT monitors that have been experienced dropping or strong mechanical shock.
- 4) Do not use or storage the TFT monitors at high temperature and high humidity environment. Particularly, never use or storage the TFT monitors at a location where condensation builds up.
- 5) Avoid using and storing TFT monitors at a location where they are exposed to direct sunlight or ultraviolet rays to prevent the LCD panels from deterioration by ultraviolet rays.
- 6) Do not stain or damage the contacts of the FPC cable .
FPC cable needs to be inserted until it can reach to the end of connector slot.
During insertion, make sure to keep the cable in a horizontal position to avoid an oblique insertion.
Otherwise, it may cause poor contact or deteriorate reliability of the FPC cable.
- 7) Do not bend or pull the FPC cable or carry the TFT monitor by holding the FPC cable.
Especially, it will cause mechanical damage or critical defect if FPC is pull up or bent up to short of display.

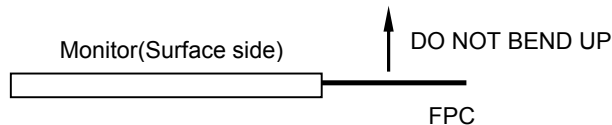

- 8) Peel off the protective film on the TFT monitors during mounting process.
Refer to the section 16.5 on how to peel off the protective film.
We are not responsible for electrostatic discharge failures or other defects occur when peeling off the protective film.
- 9) It is recommended to employ the structure of which polarizer peripheral area of LCD panel being pressed by cushioning materials, in order to prevent a cause of display brightness unevenness.
- 10) A bonding of tempered glass with the thickness of 1.1mm or more is recommended.

16.3 Precautions for Operation

- 1) Since this TFT monitors are not equipped with light shielding for the driver IC, do not expose the driver IC to strong lights during operation as it may cause functional failures.
- 2) In case of powering up or powering off this LCD module, be sure to comply the sequence as instructed in this specification.
- 3) Do not plug in or out the FPC cable while power supply is switch on.
Plug the FPC cable in and out while power supply is switched off.
- 4) Do not operate the TFT monitors in the strong magnetic field. It may break the TFT monitors.
- 5) Do not display a fixed image on the screen for a long time.
Use a screen-saver or other measures to avoid a fixed image displayed on the screen for a long time.
Otherwise, it may cause burn-in image on the screen due the characteristics of liquid crystal.

16.4 Storage Condition for Shipping Cartons

Storage environment

- Temperature 0 to 40° C
- Humidity 60%RH or less
No-condensing occurs under low temperature with high humidity condition.
- Atmosphere No poisonous gas that can erode electronic components and/or wiring materials should be detected.
- Time period 1 year
- Unpacking To prevent damages caused by static electricity, anti-static precautionary measures (e.g. earthing, anti-static mat) should be implemented.
After unpack, keep product in the appropriate condition, otherwise bubble seal of Protective film may be printed on Polarizer.
- Maximum piling up 7 cartons

*Conditions to storage after unpacking

Storage environment

- Temperature 0 to 40° C
- Humidity 60%RH or less
No-condensing occurs under low temperature with high humidity condition.
- Atmosphere No poisonous gas that can erode electronic components and/or wiring materials should be detected.
- Time period 1 year (Shelf life)
- Others Keep/ store away from direct sunlight
Storage goods on original tray made by TOPPAN PRINTING.

16.5 Precautions for Peeling off the Protective film

The followings work environment and work method are recommended to prevent the TFT monitors from static damage or adhesion of dust when peeling off the protective films.

A) Work Environment

- a) Humidity: 50 to 70 %RH, Temperature 15 to 27 °C
- b) Operators should wear conductive shoes, conductive clothes, conductive finger tips and grounded wrist-straps.
Use an electrostatic neutralization blower.
Anti-static treatment should be implemented to work area's floor.
- c) Use a room shielded against outside dust with sticky floor mat laid at the entrance to eliminate dirt.

B) Work Method

The following procedures should be taken to prevent the driver ICs from charging and discharging.

- a) Use an electrostatic neutralization blower to blow air on the TFT monitors to its lower left when FPC is placed at the bottom.
Optimize direction of the blowing air and the distance between the TFT monitors and the electrostatic neutralization blower.
- b) Put an adhesive tape (Scotch tape, etc) at the lower left corner area of the protective film to prevent scratch on surface of TFT monitors.
- c) Peel off the adhesive tape slowly (spending more than 2 secs to complete) by pulling it to opposite direction.

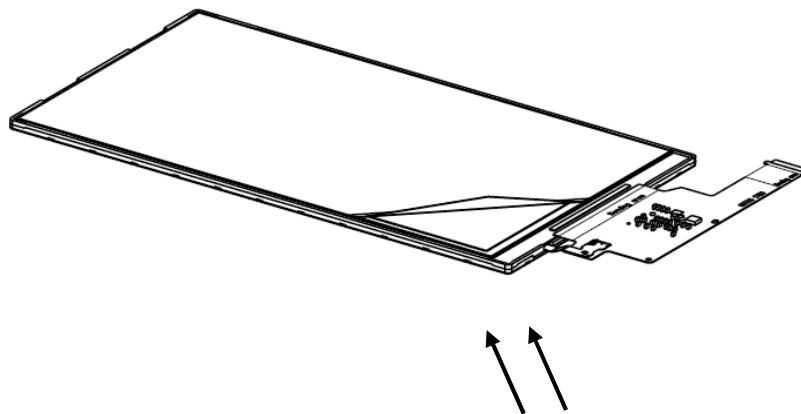

Blower wind direction (Set an ion blower with its adequate conditions.)

16.6 Warranty

TOPPAN PRINTING is only liable to defective goods which is stored and used under the condition complying with this specifications and returned within 1 (one) year.

Warranty caused by manufacturing defect shall be conducted by replacement of goods or refundment at unit price.

APPENDIX

Reference Method for Measuring Optical Characteristics and Performance

1. Measurement Condition (Backlight ON)



Measuring instruments: CS2000 (KONICA MINOLTA), LCD7200(OTSUKA ELECTRONICS),EZcontrast160D (ELDIM)

Driving condition: Refer to the section "Optical Characteristics"

Measured temperature: 25° C unless specified

Measurement system: See the chart below. The luminance meter is placed on the normal line of measurement system.

Measurement point: At the center of the screen unless otherwise specified

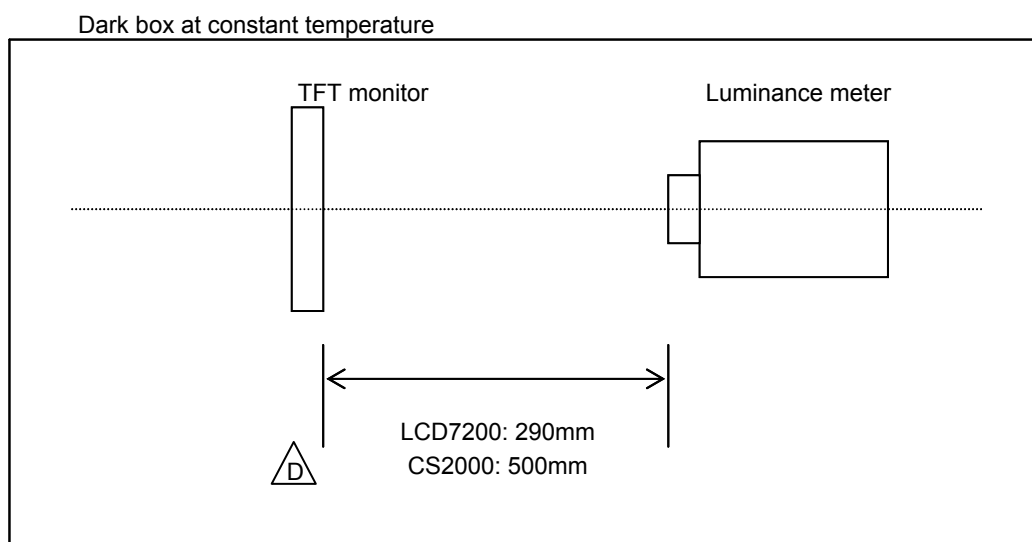

Measurement is made after 30 minutes of lighting of the backlight.

Measurement point: At the center point of the screen
Brightness distribution: 9 points shown in the following drawing.

<Portrait model>

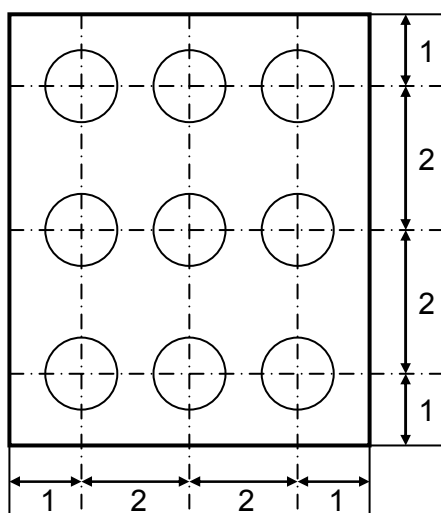

Dimensional ratio of active area

Backlight IL=10.0mA

Measurement Condition (Contrast ratio Backlight OFF only)

Measuring instruments: LCD7200(OTSUKA ELECTRONICS),Ring Light(40,000 lx, ϕ 58)

Driving condition: Refer to the section "Optical Characteristics"

Measured temperature: 25°C unless specified

Measurement system: See the chart below.

Measurement point: At the center of the screen.

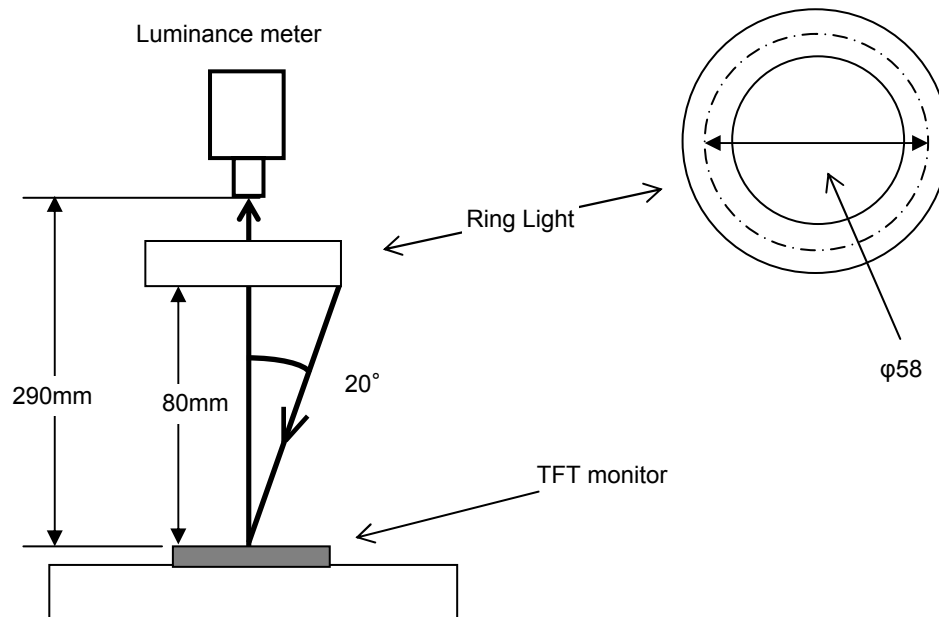



2. Test Method

Notice	Item	Test method	Measuring instrument	Remark
1	Response time	<p>Measure output signal waves with a brightness meter when the raster or window pattern is changed over from white to black and from black to white</p> <p style="text-align: center;">Black White Black</p> <p>White brightness</p> <p>100%</p> <p>90%</p> <p>10%</p> <p>0%</p> <p>Black brightness</p> <p style="text-align: center;">← TON ← TOFF</p>	LCD7200	<p>Black display [Data]=00h</p> <p>White display [Data]=FFh</p> <p>TON</p> <p>Rise time</p> <p>TOFF</p> <p>Fall time</p>
2	Contrast ratio	<p>Measure maximum luminance Y1([Data]=FFh) and minimum luminance Y2([Data]=00h) at the center of the screen by displaying raster or window pattern. Then calculate the ratio between these two values.</p> <p style="text-align: center;">Contrast ratio = Y1/Y2</p> <p style="text-align: center;">Diameter of measuring point: 7.8mmφ(CS2000)</p> <p style="text-align: center;">Diameter of measuring point: 3mmφ(LCD7200)</p>	CS2000 LCD7200	Backlight ON Backlight OFF
3	Viewing angle Horizontalθ Verticalφ	Move the luminance meter from right to left and up and down and determine the angles where contrast ratio is 10.	EZcontrast160D	
4	White chromaticity	<p>Measure chromaticity coordinates x and y of CIE1931 colorimetric system at [Data] = FFh</p> <p style="text-align: center;">Color matching function: 2°view</p> <p style="text-align: center;">Measurement angle: 1°</p>	CS2000	
5	Burn-in	Visually check burn-in image on the screen after 2 hours of "window display" ([Data]=00h/FFh).		At optimized VCOMDC
6	Center brightness	Measure the brightness at the center of the screen.	CS2000	
7	Brightness distribution	<p>(Brightness distribution) = 100 x B/A %</p> <p>A : max. brightness of the 9 points</p> <p>B : min. brightness of the 9 points</p>	CS2000	

Our company network supports you worldwide with offices in Germany, Austria, Switzerland, the UK and the USA. For more information please contact:

Headquarters

Germany



FORTEC Elektronik AG

Augsburger Str. 2b
82110 Germering

Phone: +49 89 894450-0
E-Mail: info@forteca.de
Internet: www.forteca.de

Fortec Group Members

Austria



Distec GmbH Office Vienna

Nuschinggasse 12
1230 Wien

Phone: +43 1 8673492-0
E-Mail: info@distec.de
Internet: www.distec.de

Germany



Distec GmbH

Augsburger Str. 2b
82110 Germering

Phone: +49 89 894363-0
E-Mail: info@distec.de
Internet: www.distec.de

Switzerland



ALTRAC AG

Bahnhofstraße 3
5436 Würenlos

Phone: +41 44 7446111
E-Mail: info@altrac.ch
Internet: www.altrac.ch

United Kingdom



Display Technology Ltd.

Osprey House, 1 Osprey Court
Hichingbrooke Business Park
Huntingdon, Cambridgeshire, PE29 6FN

Phone: +44 1480 411600
E-Mail: info@displaytechnology.co.uk
Internet: www.displaytechnology.co.uk

USA



Apollo Display Technologies, Corp.

87 Raynor Avenue,
Unit 1 Ronkonkoma,
NY 11779

Phone: +1 631 5804360
E-Mail: info@apolloDisplays.com
Internet: www.apolloDisplays.com