



OUR GLOBAL
COMPETENCE
CENTRES

 APOLLO DISPLAY
TECHNOLOGIES



 DISTEC



 DISPLAY
TECHNOLOGY



Datasheet

AUO

G286HAN01.0

UP-02-162

The information contained in this document has been carefully researched and is, to the best of our knowledge, accurate. However, we assume no liability for any product failures or damages, immediate or consequential, resulting from the use of the information provided herein. Our products are not intended for use in systems in which failures of product could result in personal injury. All trademarks mentioned herein are property of their respective owners. All specifications are subject to change without notice.



Product Specification

G286HAN01.0

AU OPTRONICS CORPORATION

- Preliminary Specification
- Final Specification

Module	28.6" Color TFT-LCD
Model Name	G286HAN01.0

Customer	Date
_____	_____
Checked & Approved by	
_____	_____
<p>Note: This Specification is subject to change without notice.</p>	

Approved by	Date
Crystal Hsieh	2017/06/06
Prepared by	
Jimmy Tsai	2017/06/06
<p>General Display Business Unit / AU Optronics corporation</p>	

Contents

1. Operating Precautions	5
2. General Description	6
2.1 Display Characteristics	6
2.2 Optical Characteristics	7
3. Functional Block Diagram	10
4. Absolute Maximum Ratings	11
4.1 TFT LCD Module	11
4.2 Backlight Unit.....	11
4.3 Absolute Ratings of Environment	11
5. Electrical Characteristics	12
5.1 TFT LCD Module	12
5.2 Backlight Unit.....	14
6. Signal Characteristic	15
6.1 Pixel Format Image	15
6.2 Signal Description.....	16
6.3 The Input Data Format	18
6.4 Interface Timing	19
6.5 Power ON/OFF Sequence.....	20
7. Connector & Pin Assignment	21
7.1 TFT LCD Module: LVDS Connector	21
7.2 Backlight Unit: LED Light Bar Connector.....	22
8. Reliability Test	23
9. Mechanical Characteristics	24
10. Label and Packaging	25
10.1 Shipping Label (on the rear side of TFT-LCD display).....	25
10.2 Carton Package.....	25
11. Safety	26
11.1 Sharp Edge Requirements.....	26
11.2 Materials	26
11.3 Capacitors.....	26
11.4 National Test Lab Requirement.....	26



Record of Revision

Version and Date	Page	Old description	New Description	Remark																																																																						
0.1 2016/03/01	All	First Edition for Customer	All																																																																							
0.2 2016/03/14	6	<table border="1"> <thead> <tr> <th>Item</th> <th>Unit</th> <th>Conditions</th> <th>Min</th> <th>Typ</th> <th>Max</th> <th>Note</th> </tr> </thead> <tbody> <tr> <td>White Luminance</td> <td>cd/m²</td> <td>I_{sc}=100mA</td> <td>800</td> <td>1000</td> <td>-</td> <td>1</td> </tr> </tbody> </table>	Item	Unit	Conditions	Min	Typ	Max	Note	White Luminance	cd/m ²	I _{sc} =100mA	800	1000	-	1	<table border="1"> <thead> <tr> <th>Item</th> <th>Unit</th> <th>Conditions</th> <th>Min</th> <th>Typ</th> <th>Max</th> <th>Note</th> </tr> </thead> <tbody> <tr> <td>White Luminance</td> <td>cd/m²</td> <td>I_{sc}=120mA</td> <td>800</td> <td>1000</td> <td>-</td> <td>1</td> </tr> </tbody> </table>	Item	Unit	Conditions	Min	Typ	Max	Note	White Luminance	cd/m ²	I _{sc} =120mA	800	1000	-	1																																											
Item	Unit	Conditions	Min	Typ	Max	Note																																																																				
White Luminance	cd/m ²	I _{sc} =100mA	800	1000	-	1																																																																				
Item	Unit	Conditions	Min	Typ	Max	Note																																																																				
White Luminance	cd/m ²	I _{sc} =120mA	800	1000	-	1																																																																				
	18	<table border="1"> <thead> <tr> <th>Horizontal Section</th> <th>Period</th> <th>I_{sc}</th> <th>TBD</th> <th>2586</th> <th>TBD</th> </tr> </thead> <tbody> <tr> <td>Active</td> <td>I_{sc}</td> <td>TBD</td> <td>1926</td> <td>TBD</td> <td>L_clock</td> </tr> <tr> <td>Blanking</td> <td>T_{sc}</td> <td>TBD</td> <td>646</td> <td>TBD</td> <td>-</td> </tr> </tbody> </table>	Horizontal Section	Period	I _{sc}	TBD	2586	TBD	Active	I _{sc}	TBD	1926	TBD	L_clock	Blanking	T _{sc}	TBD	646	TBD	-	<table border="1"> <thead> <tr> <th>Horizontal Section</th> <th>Period</th> <th>T_{sc}</th> <th>TRF</th> <th>128</th> <th>TRF</th> </tr> </thead> <tbody> <tr> <td>Active</td> <td>I_{sc}</td> <td>TBD</td> <td>960</td> <td>TBD</td> <td>L_clock</td> </tr> <tr> <td>Blanking</td> <td>T_{sc}</td> <td>TBD</td> <td>323</td> <td>TRF</td> <td>-</td> </tr> </tbody> </table>	Horizontal Section	Period	T _{sc}	TRF	128	TRF	Active	I _{sc}	TBD	960	TBD	L_clock	Blanking	T _{sc}	TBD	323	TRF	-																																			
Horizontal Section	Period	I _{sc}	TBD	2586	TBD																																																																					
Active	I _{sc}	TBD	1926	TBD	L_clock																																																																					
Blanking	T _{sc}	TBD	646	TBD	-																																																																					
Horizontal Section	Period	T _{sc}	TRF	128	TRF																																																																					
Active	I _{sc}	TBD	960	TBD	L_clock																																																																					
Blanking	T _{sc}	TBD	323	TRF	-																																																																					
	19	<table border="1"> <thead> <tr> <th colspan="5">Power Sequence Timing</th> </tr> <tr> <th rowspan="2">Parameter</th> <th colspan="3">Value</th> <th rowspan="2">Units</th> </tr> <tr> <th>Min</th> <th>Typ</th> <th>Max</th> </tr> </thead> <tbody> <tr> <td>T1</td> <td>0.5</td> <td>-</td> <td>10</td> <td rowspan="7">ms</td> </tr> <tr> <td>T2</td> <td>30</td> <td>40</td> <td>50</td> </tr> <tr> <td>T11</td> <td>0</td> <td>16</td> <td>50</td> </tr> <tr> <td>T12</td> <td>-</td> <td>-</td> <td>10</td> </tr> <tr> <td>T13</td> <td>1000</td> <td>-</td> <td>-</td> </tr> </tbody> </table>	Power Sequence Timing					Parameter	Value			Units	Min	Typ	Max	T1	0.5	-	10	ms	T2	30	40	50	T11	0	16	50	T12	-	-	10	T13	1000	-	-	<table border="1"> <thead> <tr> <th colspan="4">Power Sequence Timing</th> </tr> <tr> <th rowspan="2">Parameter</th> <th colspan="2">Value</th> <th rowspan="2">Units</th> </tr> <tr> <th>Min</th> <th>Max</th> </tr> </thead> <tbody> <tr> <td>T1</td> <td>0.5</td> <td>10</td> <td rowspan="7">ms</td> </tr> <tr> <td>T2</td> <td>30</td> <td>50</td> </tr> <tr> <td>T3</td> <td>200</td> <td>-</td> </tr> <tr> <td>T4</td> <td>200</td> <td>-</td> </tr> <tr> <td>T5</td> <td>0</td> <td>50</td> </tr> <tr> <td>T6</td> <td>0</td> <td>10</td> </tr> <tr> <td>T7</td> <td>1000</td> <td>-</td> </tr> </tbody> </table>	Power Sequence Timing				Parameter	Value		Units	Min	Max	T1	0.5	10	ms	T2	30	50	T3	200	-	T4	200	-	T5	0	50	T6	0	10	T7	1000	-					
Power Sequence Timing																																																																										
Parameter	Value			Units																																																																						
	Min	Typ	Max																																																																							
T1	0.5	-	10	ms																																																																						
T2	30	40	50																																																																							
T11	0	16	50																																																																							
T12	-	-	10																																																																							
T13	1000	-	-																																																																							
Power Sequence Timing																																																																										
Parameter	Value		Units																																																																							
	Min	Max																																																																								
T1	0.5	10	ms																																																																							
T2	30	50																																																																								
T3	200	-																																																																								
T4	200	-																																																																								
T5	0	50																																																																								
T6	0	10																																																																								
T7	1000	-																																																																								
0.3 2016/07/14	5	Power Consumption [Watt] TBD	Power Consumption [Watt] 24.23 W(Max) = 3.5 W (Cell) +20.73 W (light bar)																																																																							
	6	<table border="1"> <thead> <tr> <th>Color</th> <th>Min</th> <th>Typ</th> <th>Max</th> </tr> </thead> <tbody> <tr> <td>Red x</td> <td rowspan="8">-0.05</td> <td rowspan="8">TBD</td> <td rowspan="8">+0.05</td> </tr> <tr> <td>Red y</td> </tr> <tr> <td>Green x</td> </tr> <tr> <td>Green y</td> </tr> <tr> <td>Blue x</td> </tr> <tr> <td>Blue y</td> </tr> <tr> <td>White x</td> <td>0.313</td> </tr> <tr> <td>White y</td> <td>0.329</td> </tr> </tbody> </table>	Color	Min	Typ	Max	Red x	-0.05	TBD	+0.05	Red y	Green x	Green y	Blue x	Blue y	White x	0.313	White y	0.329	<table border="1"> <thead> <tr> <th>Color</th> <th>Min</th> <th>Typ</th> <th>Max</th> </tr> </thead> <tbody> <tr> <td>Red x</td> <td rowspan="8">-0.05</td> <td rowspan="8">TBD</td> <td>0.64</td> </tr> <tr> <td>Red y</td> <td>0.345</td> </tr> <tr> <td>Green x</td> <td>0.324</td> </tr> <tr> <td>Green y</td> <td>0.627</td> </tr> <tr> <td>Blue x</td> <td>0.152</td> </tr> <tr> <td>Blue y</td> <td>0.057</td> </tr> <tr> <td>White x</td> <td>0.313</td> </tr> <tr> <td>White y</td> <td>0.329</td> </tr> </tbody> </table>	Color	Min	Typ	Max	Red x	-0.05	TBD	0.64	Red y	0.345	Green x	0.324	Green y	0.627	Blue x	0.152	Blue y	0.057	White x	0.313	White y	0.329																																
Color	Min	Typ	Max																																																																							
Red x	-0.05	TBD	+0.05																																																																							
Red y																																																																										
Green x																																																																										
Green y																																																																										
Blue x																																																																										
Blue y																																																																										
White x				0.313																																																																						
White y				0.329																																																																						
Color	Min	Typ	Max																																																																							
Red x	-0.05	TBD	0.64																																																																							
Red y			0.345																																																																							
Green x			0.324																																																																							
Green y			0.627																																																																							
Blue x			0.152																																																																							
Blue y			0.057																																																																							
White x			0.313																																																																							
White y			0.329																																																																							
	10	<table border="1"> <thead> <tr> <th>Item</th> <th>Symbol</th> <th>Min</th> <th>Max</th> <th>Unit</th> <th>Conditions</th> </tr> </thead> <tbody> <tr> <td>LED LB Input Voltage</td> <td>V_{cc}</td> <td>TBD</td> <td>TBD</td> <td>[Volt]</td> <td>Note 1,2</td> </tr> </tbody> </table>	Item	Symbol	Min	Max	Unit	Conditions	LED LB Input Voltage	V _{cc}	TBD	TBD	[Volt]	Note 1,2	<table border="1"> <thead> <tr> <th>Item</th> <th>Symbol</th> <th>Min</th> <th>Max</th> <th>Unit</th> <th>Conditions</th> </tr> </thead> <tbody> <tr> <td>LED LB Input Voltage</td> <td>V_{cc}</td> <td>43.2</td> <td>43.2</td> <td>[Volt]</td> <td>Note 1,2</td> </tr> </tbody> </table>	Item	Symbol	Min	Max	Unit	Conditions	LED LB Input Voltage	V _{cc}	43.2	43.2	[Volt]	Note 1,2																																															
Item	Symbol	Min	Max	Unit	Conditions																																																																					
LED LB Input Voltage	V _{cc}	TBD	TBD	[Volt]	Note 1,2																																																																					
Item	Symbol	Min	Max	Unit	Conditions																																																																					
LED LB Input Voltage	V _{cc}	43.2	43.2	[Volt]	Note 1,2																																																																					
	11	<table border="1"> <thead> <tr> <th>Symbol</th> <th>Parameter</th> <th>Min</th> <th>Typ</th> <th>Max</th> <th>Units</th> <th>Remark</th> </tr> </thead> <tbody> <tr> <td>VDD</td> <td>Logic/LCD Drive Voltage</td> <td>10.8</td> <td>12</td> <td>13.2</td> <td>[Volt]</td> <td>±10%</td> </tr> <tr> <td>IDD</td> <td>VDD Current</td> <td>-</td> <td>TBD</td> <td>TBD</td> <td>[mA]</td> <td>VDD=5.0V, All White Pattern At 60Hz</td> </tr> <tr> <td>I_{ush}</td> <td>LCD Inrush Current</td> <td>-</td> <td>TBD</td> <td>[A]</td> <td>VDD=5.0V, All White Pattern At 60Hz</td> </tr> <tr> <td>PDD</td> <td>VDD Power</td> <td>-</td> <td>TRF</td> <td>TRF</td> <td>[Watt]</td> <td>VDD=5.0V, All White Pattern At 60Hz</td> </tr> </tbody> </table>	Symbol	Parameter	Min	Typ	Max	Units	Remark	VDD	Logic/LCD Drive Voltage	10.8	12	13.2	[Volt]	±10%	IDD	VDD Current	-	TBD	TBD	[mA]	VDD=5.0V, All White Pattern At 60Hz	I _{ush}	LCD Inrush Current	-	TBD	[A]	VDD=5.0V, All White Pattern At 60Hz	PDD	VDD Power	-	TRF	TRF	[Watt]	VDD=5.0V, All White Pattern At 60Hz	<table border="1"> <thead> <tr> <th>Symbol</th> <th>Parameter</th> <th>Min</th> <th>Typ</th> <th>Max</th> <th>Units</th> <th>Remark</th> </tr> </thead> <tbody> <tr> <td>VDD</td> <td>Logic/LCD Drive Voltage</td> <td>10.8</td> <td>12</td> <td>13.2</td> <td>[Volt]</td> <td>±10%</td> </tr> <tr> <td>IDD</td> <td>VDD Current</td> <td>-</td> <td>292</td> <td>-</td> <td>[mA]</td> <td>VDD=12V, All White Pattern At 60Hz</td> </tr> <tr> <td>I_{ush}</td> <td>LCD Inrush Current</td> <td>-</td> <td>3</td> <td>-</td> <td>[A]</td> <td>Note 1</td> </tr> <tr> <td>PDD</td> <td>VDD Power</td> <td>-</td> <td>3.5</td> <td>-</td> <td>[Watt]</td> <td>VDD=12V, All White Pattern At 60Hz</td> </tr> </tbody> </table>	Symbol	Parameter	Min	Typ	Max	Units	Remark	VDD	Logic/LCD Drive Voltage	10.8	12	13.2	[Volt]	±10%	IDD	VDD Current	-	292	-	[mA]	VDD=12V, All White Pattern At 60Hz	I _{ush}	LCD Inrush Current	-	3	-	[A]	Note 1	PDD	VDD Power	-	3.5	-	[Watt]	VDD=12V, All White Pattern At 60Hz		
Symbol	Parameter	Min	Typ	Max	Units	Remark																																																																				
VDD	Logic/LCD Drive Voltage	10.8	12	13.2	[Volt]	±10%																																																																				
IDD	VDD Current	-	TBD	TBD	[mA]	VDD=5.0V, All White Pattern At 60Hz																																																																				
I _{ush}	LCD Inrush Current	-	TBD	[A]	VDD=5.0V, All White Pattern At 60Hz																																																																					
PDD	VDD Power	-	TRF	TRF	[Watt]	VDD=5.0V, All White Pattern At 60Hz																																																																				
Symbol	Parameter	Min	Typ	Max	Units	Remark																																																																				
VDD	Logic/LCD Drive Voltage	10.8	12	13.2	[Volt]	±10%																																																																				
IDD	VDD Current	-	292	-	[mA]	VDD=12V, All White Pattern At 60Hz																																																																				
I _{ush}	LCD Inrush Current	-	3	-	[A]	Note 1																																																																				
PDD	VDD Power	-	3.5	-	[Watt]	VDD=12V, All White Pattern At 60Hz																																																																				
	13	<table border="1"> <thead> <tr> <th>Symbol</th> <th>Parameter</th> <th>Min</th> <th>Typ</th> <th>Max</th> <th>Unit</th> <th>Remark</th> </tr> </thead> <tbody> <tr> <td>I_f</td> <td>LED Forward Current</td> <td>120</td> <td>-</td> <td>mA</td> <td>Ta = 25°C</td> </tr> <tr> <td>V_f LED</td> <td>Forward Voltage</td> <td>TBD</td> <td>-</td> <td>Volt</td> <td>Ta = 25°C</td> </tr> <tr> <td>P_{LED}</td> <td>LED Power Consumption</td> <td>18.43</td> <td>20.73</td> <td>Watt</td> <td>Ta = 25°C, Note 3</td> </tr> <tr> <td>LTLED</td> <td>LED Life Time</td> <td>50,000</td> <td>-</td> <td>Hrs</td> <td>Ta = 25°C, Note 4</td> </tr> </tbody> </table>	Symbol	Parameter	Min	Typ	Max	Unit	Remark	I _f	LED Forward Current	120	-	mA	Ta = 25°C	V _f LED	Forward Voltage	TBD	-	Volt	Ta = 25°C	P _{LED}	LED Power Consumption	18.43	20.73	Watt	Ta = 25°C, Note 3	LTLED	LED Life Time	50,000	-	Hrs	Ta = 25°C, Note 4	<table border="1"> <thead> <tr> <th>Symbol</th> <th>Parameter</th> <th>Min</th> <th>Typ</th> <th>Max</th> <th>Unit</th> <th>Remark</th> </tr> </thead> <tbody> <tr> <td>I_f</td> <td>LED Forward Current</td> <td>120</td> <td>-</td> <td>mA</td> <td>Ta = 25°C</td> </tr> <tr> <td>V_f LED</td> <td>Forward Voltage</td> <td>38.4</td> <td>43.2</td> <td>Volt</td> <td>Ta = 25°C</td> </tr> <tr> <td>P_{LED}</td> <td>LED Power Consumption</td> <td>18.43</td> <td>20.73</td> <td>Watt</td> <td>Ta = 25°C, Note 3</td> </tr> <tr> <td>LTLED</td> <td>LED Life Time</td> <td>50,000</td> <td>-</td> <td>Hrs</td> <td>Lx2: 18.43x2=36.86(typ) Ta = 25°C, Note 4</td> </tr> </tbody> </table>	Symbol	Parameter	Min	Typ	Max	Unit	Remark	I _f	LED Forward Current	120	-	mA	Ta = 25°C	V _f LED	Forward Voltage	38.4	43.2	Volt	Ta = 25°C	P _{LED}	LED Power Consumption	18.43	20.73	Watt	Ta = 25°C, Note 3	LTLED	LED Life Time	50,000	-	Hrs	Lx2: 18.43x2=36.86(typ) Ta = 25°C, Note 4									
Symbol	Parameter	Min	Typ	Max	Unit	Remark																																																																				
I _f	LED Forward Current	120	-	mA	Ta = 25°C																																																																					
V _f LED	Forward Voltage	TBD	-	Volt	Ta = 25°C																																																																					
P _{LED}	LED Power Consumption	18.43	20.73	Watt	Ta = 25°C, Note 3																																																																					
LTLED	LED Life Time	50,000	-	Hrs	Ta = 25°C, Note 4																																																																					
Symbol	Parameter	Min	Typ	Max	Unit	Remark																																																																				
I _f	LED Forward Current	120	-	mA	Ta = 25°C																																																																					
V _f LED	Forward Voltage	38.4	43.2	Volt	Ta = 25°C																																																																					
P _{LED}	LED Power Consumption	18.43	20.73	Watt	Ta = 25°C, Note 3																																																																					
LTLED	LED Life Time	50,000	-	Hrs	Lx2: 18.43x2=36.86(typ) Ta = 25°C, Note 4																																																																					
0.4 2016/08/17	5	Power Consumption [Watt] 24.23 W(Max) = 3.5 W (Cell) +20.73 W (light bar)	Power Consumption [Watt] 44.96 W(Max) = 3.5 W (Cell) +41.46 W (light bar)																																																																							
	13	<table border="1"> <thead> <tr> <th>Symbol</th> <th>Parameter</th> <th>Min</th> <th>Typ</th> <th>Max</th> <th>Unit</th> <th>Remark</th> </tr> </thead> <tbody> <tr> <td>I_f</td> <td>LED Forward Current</td> <td>120</td> <td>-</td> <td>mA</td> <td>Ta = 25°C</td> </tr> <tr> <td>V_f LED</td> <td>Forward Voltage</td> <td>38.4</td> <td>43.2</td> <td>Volt</td> <td>Ta = 25°C</td> </tr> <tr> <td>P_{LED}</td> <td>LED Power Consumption</td> <td>18.43</td> <td>20.73</td> <td>Watt</td> <td>Ta = 25°C, Note 3</td> </tr> <tr> <td>LTLED</td> <td>LED Life Time</td> <td>50,000</td> <td>-</td> <td>Hrs</td> <td>Ta = 25°C, Note 4</td> </tr> </tbody> </table>	Symbol	Parameter	Min	Typ	Max	Unit	Remark	I _f	LED Forward Current	120	-	mA	Ta = 25°C	V _f LED	Forward Voltage	38.4	43.2	Volt	Ta = 25°C	P _{LED}	LED Power Consumption	18.43	20.73	Watt	Ta = 25°C, Note 3	LTLED	LED Life Time	50,000	-	Hrs	Ta = 25°C, Note 4	<table border="1"> <thead> <tr> <th>Symbol</th> <th>Parameter</th> <th>Min</th> <th>Typ</th> <th>Max</th> <th>Unit</th> <th>Remark</th> </tr> </thead> <tbody> <tr> <td>I_f</td> <td>LED Forward Current</td> <td>120</td> <td>-</td> <td>mA</td> <td>Ta = 25°C</td> </tr> <tr> <td>V_f LED</td> <td>Forward Voltage</td> <td>38.4</td> <td>43.2</td> <td>Volt</td> <td>Ta = 25°C</td> </tr> <tr> <td>P_{LED}</td> <td>LED Power Consumption (Single light bar)</td> <td>18.43</td> <td>20.73</td> <td>Watt</td> <td>Ta = 25°C, Note 3</td> </tr> <tr> <td>LTLED</td> <td>LED Life Time</td> <td>50,000</td> <td>-</td> <td>Hrs</td> <td>There are two light bars Ta = 25°C, Note 4</td> </tr> </tbody> </table>	Symbol	Parameter	Min	Typ	Max	Unit	Remark	I _f	LED Forward Current	120	-	mA	Ta = 25°C	V _f LED	Forward Voltage	38.4	43.2	Volt	Ta = 25°C	P _{LED}	LED Power Consumption (Single light bar)	18.43	20.73	Watt	Ta = 25°C, Note 3	LTLED	LED Life Time	50,000	-	Hrs	There are two light bars Ta = 25°C, Note 4									
Symbol	Parameter	Min	Typ	Max	Unit	Remark																																																																				
I _f	LED Forward Current	120	-	mA	Ta = 25°C																																																																					
V _f LED	Forward Voltage	38.4	43.2	Volt	Ta = 25°C																																																																					
P _{LED}	LED Power Consumption	18.43	20.73	Watt	Ta = 25°C, Note 3																																																																					
LTLED	LED Life Time	50,000	-	Hrs	Ta = 25°C, Note 4																																																																					
Symbol	Parameter	Min	Typ	Max	Unit	Remark																																																																				
I _f	LED Forward Current	120	-	mA	Ta = 25°C																																																																					
V _f LED	Forward Voltage	38.4	43.2	Volt	Ta = 25°C																																																																					
P _{LED}	LED Power Consumption (Single light bar)	18.43	20.73	Watt	Ta = 25°C, Note 3																																																																					
LTLED	LED Life Time	50,000	-	Hrs	There are two light bars Ta = 25°C, Note 4																																																																					
1.0 2017/06/06	6	Display Mode: V/A Mode, Normally Black	Display Mode: AHVA Mode, Normally Black																																																																							
	10	LVDS Connector: FCN CT110046-5133 or equivalent.	LVDS Connector: JAE SJ11346-FI-RTE51SZ-HF or equivalent.																																																																							
	12	<table border="1"> <thead> <tr> <th>Symbol</th> <th>Parameter</th> <th>Min</th> <th>Typ</th> <th>Max</th> <th>Units</th> <th>Remark</th> </tr> </thead> <tbody> <tr> <td>VDD</td> <td>Logic/LCD Drive Voltage</td> <td>10.8</td> <td>12</td> <td>13.2</td> <td>[Volt]</td> <td>±10%</td> </tr> <tr> <td>IDD</td> <td>VDD Current</td> <td>-</td> <td>292</td> <td>-</td> <td>[mA]</td> <td>VDD=12V, All White Pattern At 60Hz</td> </tr> <tr> <td>I_{ush}</td> <td>LCD Inrush Current</td> <td>-</td> <td>3</td> <td>-</td> <td>[A]</td> <td>Note 1</td> </tr> <tr> <td>PDD</td> <td>VDD Power</td> <td>-</td> <td>3.5</td> <td>-</td> <td>[Watt]</td> <td>VDD=12V, All White Pattern At 60Hz</td> </tr> </tbody> </table>	Symbol	Parameter	Min	Typ	Max	Units	Remark	VDD	Logic/LCD Drive Voltage	10.8	12	13.2	[Volt]	±10%	IDD	VDD Current	-	292	-	[mA]	VDD=12V, All White Pattern At 60Hz	I _{ush}	LCD Inrush Current	-	3	-	[A]	Note 1	PDD	VDD Power	-	3.5	-	[Watt]	VDD=12V, All White Pattern At 60Hz	<table border="1"> <thead> <tr> <th>Symbol</th> <th>Parameter</th> <th>Min</th> <th>Typ</th> <th>Max</th> <th>Units</th> <th>Remark</th> </tr> </thead> <tbody> <tr> <td>VDD</td> <td>Logic/LCD Drive Voltage</td> <td>10.8</td> <td>12</td> <td>13.2</td> <td>[Volt]</td> <td>±10%</td> </tr> <tr> <td>IDD</td> <td>VDD Current</td> <td>-</td> <td>0.23</td> <td>-</td> <td>[A]</td> <td>VDD=12V, All White Pattern At 60Hz</td> </tr> <tr> <td>I_{ush}</td> <td>LCD Inrush Current</td> <td>-</td> <td>3</td> <td>-</td> <td>[A]</td> <td>Note 1</td> </tr> <tr> <td>PDD</td> <td>VDD Power</td> <td>-</td> <td>3.50</td> <td>-</td> <td>[Watt]</td> <td>VDD=12V, All White Pattern At 60Hz</td> </tr> </tbody> </table>	Symbol	Parameter	Min	Typ	Max	Units	Remark	VDD	Logic/LCD Drive Voltage	10.8	12	13.2	[Volt]	±10%	IDD	VDD Current	-	0.23	-	[A]	VDD=12V, All White Pattern At 60Hz	I _{ush}	LCD Inrush Current	-	3	-	[A]	Note 1	PDD	VDD Power	-	3.50	-	[Watt]	VDD=12V, All White Pattern At 60Hz	
Symbol	Parameter	Min	Typ	Max	Units	Remark																																																																				
VDD	Logic/LCD Drive Voltage	10.8	12	13.2	[Volt]	±10%																																																																				
IDD	VDD Current	-	292	-	[mA]	VDD=12V, All White Pattern At 60Hz																																																																				
I _{ush}	LCD Inrush Current	-	3	-	[A]	Note 1																																																																				
PDD	VDD Power	-	3.5	-	[Watt]	VDD=12V, All White Pattern At 60Hz																																																																				
Symbol	Parameter	Min	Typ	Max	Units	Remark																																																																				
VDD	Logic/LCD Drive Voltage	10.8	12	13.2	[Volt]	±10%																																																																				
IDD	VDD Current	-	0.23	-	[A]	VDD=12V, All White Pattern At 60Hz																																																																				
I _{ush}	LCD Inrush Current	-	3	-	[A]	Note 1																																																																				
PDD	VDD Power	-	3.50	-	[Watt]	VDD=12V, All White Pattern At 60Hz																																																																				



Product Specification

G286HAN01.0

AU OPTRONICS CORPORATION

13	VICM- Differential Input Common Mode Voltage ¹⁾ 0.3 ²⁾ - 1.25 ³⁾ [V] ²⁾ VTH/VTL±100mV ²⁾	VICM- Differential Input Common Mode Voltage ¹⁾ 1.0 ²⁾ 1.2 ²⁾ 1.5 ²⁾ [V] ²⁾ VTH/VTL±100mV ²⁾																																																																																																																																		
19	<table border="1"> <thead> <tr> <th>Signal¹⁾</th> <th>Item²⁾</th> <th>Symbol²⁾</th> <th>Min.²⁾</th> <th>Typ.²⁾</th> <th>Max.²⁾</th> <th>Unit²⁾</th> </tr> </thead> <tbody> <tr> <td rowspan="2">Clock¹⁾</td> <td>Frequency²⁾</td> <td>1/T_{clock}²⁾</td> <td>TBD²⁾</td> <td>91²⁾</td> <td>TBD²⁾</td> <td>MHz²⁾</td> </tr> <tr> <td>Period²⁾</td> <td>T_{clock}²⁾</td> <td>TBD²⁾</td> <td>91²⁾</td> <td>TBD²⁾</td> <td>ns²⁾</td> </tr> <tr> <td rowspan="3">Frame Rate¹⁾</td> <td>Frequency²⁾</td> <td>1/T_{frame}²⁾</td> <td>50²⁾</td> <td>60²⁾</td> <td>75²⁾</td> <td>Hz²⁾</td> </tr> <tr> <td>Period²⁾</td> <td>T_{frame}²⁾</td> <td>TBD²⁾</td> <td>585²⁾</td> <td>TBD²⁾</td> <td>ms²⁾</td> </tr> <tr> <td>Active²⁾</td> <td>T_{active}²⁾</td> <td>TBD²⁾</td> <td>540²⁾</td> <td>TBD²⁾</td> <td>T_{line}²⁾</td> </tr> <tr> <td rowspan="2">Vertical Section¹⁾</td> <td>Blanking²⁾</td> <td>T_{blank}²⁾</td> <td>TBD²⁾</td> <td>45²⁾</td> <td>TBD²⁾</td> <td>T_{line}²⁾</td> </tr> <tr> <td>Active²⁾</td> <td>T_{active}²⁾</td> <td>TBD²⁾</td> <td>1283²⁾</td> <td>TBD²⁾</td> <td>T_{clock}²⁾</td> </tr> <tr> <td rowspan="2">Horizontal Section¹⁾</td> <td>Active²⁾</td> <td>T_{active}²⁾</td> <td>TBD²⁾</td> <td>960²⁾</td> <td>TBD²⁾</td> <td>T_{clock}²⁾</td> </tr> <tr> <td>Blanking²⁾</td> <td>T_{blank}²⁾</td> <td>TBD²⁾</td> <td>323²⁾</td> <td>TBD²⁾</td> <td>T_{clock}²⁾</td> </tr> </tbody> </table> <p>Note 1: DE mode only. Note 2: The above is as optimized setting. Note 3: Clock min. < Vertical/Horizontal Frame Rate < Clock max.</p>	Signal ¹⁾	Item ²⁾	Symbol ²⁾	Min. ²⁾	Typ. ²⁾	Max. ²⁾	Unit ²⁾	Clock ¹⁾	Frequency ²⁾	1/T _{clock} ²⁾	TBD ²⁾	91 ²⁾	TBD ²⁾	MHz ²⁾	Period ²⁾	T _{clock} ²⁾	TBD ²⁾	91 ²⁾	TBD ²⁾	ns ²⁾	Frame Rate ¹⁾	Frequency ²⁾	1/T _{frame} ²⁾	50 ²⁾	60 ²⁾	75 ²⁾	Hz ²⁾	Period ²⁾	T _{frame} ²⁾	TBD ²⁾	585 ²⁾	TBD ²⁾	ms ²⁾	Active ²⁾	T _{active} ²⁾	TBD ²⁾	540 ²⁾	TBD ²⁾	T _{line} ²⁾	Vertical Section ¹⁾	Blanking ²⁾	T _{blank} ²⁾	TBD ²⁾	45 ²⁾	TBD ²⁾	T _{line} ²⁾	Active ²⁾	T _{active} ²⁾	TBD ²⁾	1283 ²⁾	TBD ²⁾	T _{clock} ²⁾	Horizontal Section ¹⁾	Active ²⁾	T _{active} ²⁾	TBD ²⁾	960 ²⁾	TBD ²⁾	T _{clock} ²⁾	Blanking ²⁾	T _{blank} ²⁾	TBD ²⁾	323 ²⁾	TBD ²⁾	T _{clock} ²⁾	<table border="1"> <thead> <tr> <th>Signal¹⁾</th> <th>Item²⁾</th> <th>Symbol²⁾</th> <th>Min.²⁾</th> <th>Typ.²⁾</th> <th>Max.²⁾</th> <th>Unit²⁾</th> </tr> </thead> <tbody> <tr> <td rowspan="2">Clock¹⁾</td> <td>Frequency²⁾</td> <td>1/T_{clock}²⁾</td> <td>42²⁾</td> <td>45²⁾</td> <td>48²⁾</td> <td>MHz²⁾</td> </tr> <tr> <td>Period²⁾</td> <td>T_{clock}²⁾</td> <td>20²⁾</td> <td>45²⁾</td> <td>200²⁾</td> <td>ns²⁾</td> </tr> <tr> <td rowspan="3">Frame Rate¹⁾</td> <td>Frequency²⁾</td> <td>1/T_{frame}²⁾</td> <td>47²⁾</td> <td>60²⁾</td> <td>63²⁾</td> <td>Hz²⁾</td> </tr> <tr> <td>Period²⁾</td> <td>T_{frame}²⁾</td> <td>560²⁾</td> <td>585²⁾</td> <td>740²⁾</td> <td>ms²⁾</td> </tr> <tr> <td>Active²⁾</td> <td>T_{active}²⁾</td> <td>TBD²⁾</td> <td>540²⁾</td> <td>TBD²⁾</td> <td>T_{line}²⁾</td> </tr> <tr> <td rowspan="2">Vertical Section¹⁾</td> <td>Blanking²⁾</td> <td>T_{blank}²⁾</td> <td>20²⁾</td> <td>45²⁾</td> <td>200²⁾</td> <td>T_{line}²⁾</td> </tr> <tr> <td>Active²⁾</td> <td>T_{active}²⁾</td> <td>1030²⁾</td> <td>1283²⁾</td> <td>1325²⁾</td> <td>T_{clock}²⁾</td> </tr> <tr> <td rowspan="2">Horizontal Section¹⁾</td> <td>Active²⁾</td> <td>T_{active}²⁾</td> <td>960²⁾</td> <td>960²⁾</td> <td>960²⁾</td> <td>T_{clock}²⁾</td> </tr> <tr> <td>Blanking²⁾</td> <td>T_{blank}²⁾</td> <td>70²⁾</td> <td>323²⁾</td> <td>365²⁾</td> <td>T_{clock}²⁾</td> </tr> </tbody> </table> <p>Note 1: DE mode only. Note 2: The above is as optimized setting. Note 3: Clock min. < Vertical/Horizontal Frame Rate < Clock max.</p>	Signal ¹⁾	Item ²⁾	Symbol ²⁾	Min. ²⁾	Typ. ²⁾	Max. ²⁾	Unit ²⁾	Clock ¹⁾	Frequency ²⁾	1/T _{clock} ²⁾	42 ²⁾	45 ²⁾	48 ²⁾	MHz ²⁾	Period ²⁾	T _{clock} ²⁾	20 ²⁾	45 ²⁾	200 ²⁾	ns ²⁾	Frame Rate ¹⁾	Frequency ²⁾	1/T _{frame} ²⁾	47 ²⁾	60 ²⁾	63 ²⁾	Hz ²⁾	Period ²⁾	T _{frame} ²⁾	560 ²⁾	585 ²⁾	740 ²⁾	ms ²⁾	Active ²⁾	T _{active} ²⁾	TBD ²⁾	540 ²⁾	TBD ²⁾	T _{line} ²⁾	Vertical Section ¹⁾	Blanking ²⁾	T _{blank} ²⁾	20 ²⁾	45 ²⁾	200 ²⁾	T _{line} ²⁾	Active ²⁾	T _{active} ²⁾	1030 ²⁾	1283 ²⁾	1325 ²⁾	T _{clock} ²⁾	Horizontal Section ¹⁾	Active ²⁾	T _{active} ²⁾	960 ²⁾	960 ²⁾	960 ²⁾	T _{clock} ²⁾	Blanking ²⁾	T _{blank} ²⁾	70 ²⁾	323 ²⁾	365 ²⁾	T _{clock} ²⁾
Signal ¹⁾	Item ²⁾	Symbol ²⁾	Min. ²⁾	Typ. ²⁾	Max. ²⁾	Unit ²⁾																																																																																																																														
Clock ¹⁾	Frequency ²⁾	1/T _{clock} ²⁾	TBD ²⁾	91 ²⁾	TBD ²⁾	MHz ²⁾																																																																																																																														
	Period ²⁾	T _{clock} ²⁾	TBD ²⁾	91 ²⁾	TBD ²⁾	ns ²⁾																																																																																																																														
Frame Rate ¹⁾	Frequency ²⁾	1/T _{frame} ²⁾	50 ²⁾	60 ²⁾	75 ²⁾	Hz ²⁾																																																																																																																														
	Period ²⁾	T _{frame} ²⁾	TBD ²⁾	585 ²⁾	TBD ²⁾	ms ²⁾																																																																																																																														
	Active ²⁾	T _{active} ²⁾	TBD ²⁾	540 ²⁾	TBD ²⁾	T _{line} ²⁾																																																																																																																														
Vertical Section ¹⁾	Blanking ²⁾	T _{blank} ²⁾	TBD ²⁾	45 ²⁾	TBD ²⁾	T _{line} ²⁾																																																																																																																														
	Active ²⁾	T _{active} ²⁾	TBD ²⁾	1283 ²⁾	TBD ²⁾	T _{clock} ²⁾																																																																																																																														
Horizontal Section ¹⁾	Active ²⁾	T _{active} ²⁾	TBD ²⁾	960 ²⁾	TBD ²⁾	T _{clock} ²⁾																																																																																																																														
	Blanking ²⁾	T _{blank} ²⁾	TBD ²⁾	323 ²⁾	TBD ²⁾	T _{clock} ²⁾																																																																																																																														
Signal ¹⁾	Item ²⁾	Symbol ²⁾	Min. ²⁾	Typ. ²⁾	Max. ²⁾	Unit ²⁾																																																																																																																														
Clock ¹⁾	Frequency ²⁾	1/T _{clock} ²⁾	42 ²⁾	45 ²⁾	48 ²⁾	MHz ²⁾																																																																																																																														
	Period ²⁾	T _{clock} ²⁾	20 ²⁾	45 ²⁾	200 ²⁾	ns ²⁾																																																																																																																														
Frame Rate ¹⁾	Frequency ²⁾	1/T _{frame} ²⁾	47 ²⁾	60 ²⁾	63 ²⁾	Hz ²⁾																																																																																																																														
	Period ²⁾	T _{frame} ²⁾	560 ²⁾	585 ²⁾	740 ²⁾	ms ²⁾																																																																																																																														
	Active ²⁾	T _{active} ²⁾	TBD ²⁾	540 ²⁾	TBD ²⁾	T _{line} ²⁾																																																																																																																														
Vertical Section ¹⁾	Blanking ²⁾	T _{blank} ²⁾	20 ²⁾	45 ²⁾	200 ²⁾	T _{line} ²⁾																																																																																																																														
	Active ²⁾	T _{active} ²⁾	1030 ²⁾	1283 ²⁾	1325 ²⁾	T _{clock} ²⁾																																																																																																																														
Horizontal Section ¹⁾	Active ²⁾	T _{active} ²⁾	960 ²⁾	960 ²⁾	960 ²⁾	T _{clock} ²⁾																																																																																																																														
	Blanking ²⁾	T _{blank} ²⁾	70 ²⁾	323 ²⁾	365 ²⁾	T _{clock} ²⁾																																																																																																																														
20	<table border="1"> <thead> <tr> <th colspan="4">Power Sequence Timing¹⁾</th> </tr> <tr> <th rowspan="2">Parameter²⁾</th> <th colspan="2">Value²⁾</th> <th rowspan="2">Units²⁾</th> </tr> <tr> <th>Min.²⁾</th> <th>Max.²⁾</th> </tr> </thead> <tbody> <tr> <td>T1²⁾</td> <td>0.5²⁾</td> <td>10²⁾</td> <td rowspan="7">ms²⁾</td> </tr> <tr> <td>T2²⁾</td> <td>30²⁾</td> <td>50²⁾</td> </tr> <tr> <td>T3²⁾</td> <td>200²⁾</td> <td>-²⁾</td> </tr> <tr> <td>T4²⁾</td> <td>200²⁾</td> <td>-²⁾</td> </tr> <tr> <td>T5²⁾</td> <td>0²⁾</td> <td>50²⁾</td> </tr> <tr> <td>T6²⁾</td> <td>0²⁾</td> <td>10²⁾</td> </tr> <tr> <td>T7²⁾</td> <td>1000²⁾</td> <td>-²⁾</td> </tr> </tbody> </table>	Power Sequence Timing ¹⁾				Parameter ²⁾	Value ²⁾		Units ²⁾	Min. ²⁾	Max. ²⁾	T1 ²⁾	0.5 ²⁾	10 ²⁾	ms ²⁾	T2 ²⁾	30 ²⁾	50 ²⁾	T3 ²⁾	200 ²⁾	- ²⁾	T4 ²⁾	200 ²⁾	- ²⁾	T5 ²⁾	0 ²⁾	50 ²⁾	T6 ²⁾	0 ²⁾	10 ²⁾	T7 ²⁾	1000 ²⁾	- ²⁾	<table border="1"> <thead> <tr> <th colspan="4">Power Sequence Timing¹⁾</th> </tr> <tr> <th rowspan="2">Parameter²⁾</th> <th colspan="2">Value²⁾</th> <th rowspan="2">Units²⁾</th> </tr> <tr> <th>Min.²⁾</th> <th>Max.²⁾</th> </tr> </thead> <tbody> <tr> <td>T1²⁾</td> <td>0.5²⁾</td> <td>30²⁾</td> <td rowspan="7">ms²⁾</td> </tr> <tr> <td>T2²⁾</td> <td>10²⁾</td> <td>50²⁾</td> </tr> <tr> <td>T3²⁾</td> <td>200²⁾</td> <td>-²⁾</td> </tr> <tr> <td>T4²⁾</td> <td>200²⁾</td> <td>-²⁾</td> </tr> <tr> <td>T5²⁾</td> <td>0²⁾</td> <td>50²⁾</td> </tr> <tr> <td>T6²⁾</td> <td>0²⁾</td> <td>10²⁾</td> </tr> <tr> <td>T7²⁾</td> <td>1000²⁾</td> <td>-²⁾</td> </tr> </tbody> </table>	Power Sequence Timing ¹⁾				Parameter ²⁾	Value ²⁾		Units ²⁾	Min. ²⁾	Max. ²⁾	T1 ²⁾	0.5 ²⁾	30 ²⁾	ms ²⁾	T2 ²⁾	10 ²⁾	50 ²⁾	T3 ²⁾	200 ²⁾	- ²⁾	T4 ²⁾	200 ²⁾	- ²⁾	T5 ²⁾	0 ²⁾	50 ²⁾	T6 ²⁾	0 ²⁾	10 ²⁾	T7 ²⁾	1000 ²⁾	- ²⁾																																																																		
Power Sequence Timing ¹⁾																																																																																																																																				
Parameter ²⁾	Value ²⁾		Units ²⁾																																																																																																																																	
	Min. ²⁾	Max. ²⁾																																																																																																																																		
T1 ²⁾	0.5 ²⁾	10 ²⁾	ms ²⁾																																																																																																																																	
T2 ²⁾	30 ²⁾	50 ²⁾																																																																																																																																		
T3 ²⁾	200 ²⁾	- ²⁾																																																																																																																																		
T4 ²⁾	200 ²⁾	- ²⁾																																																																																																																																		
T5 ²⁾	0 ²⁾	50 ²⁾																																																																																																																																		
T6 ²⁾	0 ²⁾	10 ²⁾																																																																																																																																		
T7 ²⁾	1000 ²⁾	- ²⁾																																																																																																																																		
Power Sequence Timing ¹⁾																																																																																																																																				
Parameter ²⁾	Value ²⁾		Units ²⁾																																																																																																																																	
	Min. ²⁾	Max. ²⁾																																																																																																																																		
T1 ²⁾	0.5 ²⁾	30 ²⁾	ms ²⁾																																																																																																																																	
T2 ²⁾	10 ²⁾	50 ²⁾																																																																																																																																		
T3 ²⁾	200 ²⁾	- ²⁾																																																																																																																																		
T4 ²⁾	200 ²⁾	- ²⁾																																																																																																																																		
T5 ²⁾	0 ²⁾	50 ²⁾																																																																																																																																		
T6 ²⁾	0 ²⁾	10 ²⁾																																																																																																																																		
T7 ²⁾	1000 ²⁾	- ²⁾																																																																																																																																		
21	<table border="1"> <thead> <tr> <th>Connector Name / Designation¹⁾</th> <th>Interface Connector / Interface card²⁾</th> </tr> </thead> <tbody> <tr> <td>Manufacturer²⁾</td> <td>FCN²⁾</td> </tr> <tr> <td>Type Part Number²⁾</td> <td>CT110045-5133 or equivalent²⁾</td> </tr> <tr> <td>Mating Housing Part Number²⁾</td> <td>JAE FI-RE51S-HF or compatible²⁾</td> </tr> </tbody> </table>	Connector Name / Designation ¹⁾	Interface Connector / Interface card ²⁾	Manufacturer ²⁾	FCN ²⁾	Type Part Number ²⁾	CT110045-5133 or equivalent ²⁾	Mating Housing Part Number ²⁾	JAE FI-RE51S-HF or compatible ²⁾	<table border="1"> <thead> <tr> <th>Connector Name / Designation¹⁾</th> <th>Interface Connector / Interface card²⁾</th> </tr> </thead> <tbody> <tr> <td>Manufacturer²⁾</td> <td>JAE²⁾</td> </tr> <tr> <td>Type Part Number²⁾</td> <td>SJ11346-FI-RE51S2-HF or equivalent²⁾</td> </tr> <tr> <td>Mating Housing Part Number²⁾</td> <td>JAE FI-RE51S-HF or compatible²⁾</td> </tr> </tbody> </table>	Connector Name / Designation ¹⁾	Interface Connector / Interface card ²⁾	Manufacturer ²⁾	JAE ²⁾	Type Part Number ²⁾	SJ11346-FI-RE51S2-HF or equivalent ²⁾	Mating Housing Part Number ²⁾	JAE FI-RE51S-HF or compatible ²⁾																																																																																																																		
Connector Name / Designation ¹⁾	Interface Connector / Interface card ²⁾																																																																																																																																			
Manufacturer ²⁾	FCN ²⁾																																																																																																																																			
Type Part Number ²⁾	CT110045-5133 or equivalent ²⁾																																																																																																																																			
Mating Housing Part Number ²⁾	JAE FI-RE51S-HF or compatible ²⁾																																																																																																																																			
Connector Name / Designation ¹⁾	Interface Connector / Interface card ²⁾																																																																																																																																			
Manufacturer ²⁾	JAE ²⁾																																																																																																																																			
Type Part Number ²⁾	SJ11346-FI-RE51S2-HF or equivalent ²⁾																																																																																																																																			
Mating Housing Part Number ²⁾	JAE FI-RE51S-HF or compatible ²⁾																																																																																																																																			
23	<table border="1"> <tbody> <tr> <td>Temperature Humidity Bias (THB)¹⁾</td> <td>Ta= 60°C, 80%RH, 300hours²⁾</td> </tr> <tr> <td>High Temperature Operation (HTO)¹⁾</td> <td>Ta= 60°C, 50%RH, 300hours²⁾</td> </tr> </tbody> </table>	Temperature Humidity Bias (THB) ¹⁾	Ta= 60°C, 80%RH, 300hours ²⁾	High Temperature Operation (HTO) ¹⁾	Ta= 60°C, 50%RH, 300hours ²⁾	<table border="1"> <tbody> <tr> <td>Temperature Humidity Bias (THB)¹⁾</td> <td>Ta= 50°C, 80%RH, 300hours²⁾</td> </tr> <tr> <td>High Temperature Operation (HTO)¹⁾</td> <td>Ta= 60°C, 300hours²⁾</td> </tr> </tbody> </table>	Temperature Humidity Bias (THB) ¹⁾	Ta= 50°C, 80%RH, 300hours ²⁾	High Temperature Operation (HTO) ¹⁾	Ta= 60°C, 300hours ²⁾																																																																																																																										
Temperature Humidity Bias (THB) ¹⁾	Ta= 60°C, 80%RH, 300hours ²⁾																																																																																																																																			
High Temperature Operation (HTO) ¹⁾	Ta= 60°C, 50%RH, 300hours ²⁾																																																																																																																																			
Temperature Humidity Bias (THB) ¹⁾	Ta= 50°C, 80%RH, 300hours ²⁾																																																																																																																																			
High Temperature Operation (HTO) ¹⁾	Ta= 60°C, 300hours ²⁾																																																																																																																																			

1. Operating Precautions

- 1) Since front polarizer is easily damaged, pay attention not to scratch it.
- 2) Be sure to turn off power supply when inserting or disconnecting from input connector.
- 3) Wipe off water drop immediately. Long contact with water may cause discoloration or spots.
- 4) When the panel surface is soiled, wipe it with absorbent cotton or other soft cloth.
- 5) Since the panel is made of glass, it may break or crack if dropped or bumped on hard surface.
- 6) Since CMOS LSI is used in this module, take care of static electricity and insure human earth when handling.
- 7) Do not open or modify the Module Assembly.
- 8) In case if a Module has to be put back into the packing container slot after once it was taken out from the container, take it easily, or the TFT Module may be damaged.
- 9) At the insertion or removal of the Signal Interface Connector, be sure not to rotate nor tilt the Interface Connector of the TFT Module.
- 10) After installation of the TFT Module into an enclosure, do not twist nor bend the TFT Module even momentary. At designing the enclosure, it should be taken into consideration that no bending/twisting forces are applied to the TFT Module from outside. Otherwise the TFT Module may be damaged.
- 11) Small amount of materials having no flammability grade is used in the LCD module. The LCD module should be supplied by power complied with requirements of Limited Power Source (IEC60950 or UL1950), or be applied exemption.
- 12) Severe temperature condition may result in different luminance, response time and LED life time.
- 13) The data on this specification sheet is applicable when LCD module is placed in landscape position.
- 14) Continuous displaying fixed pattern may induce image sticking. It is recommended to use screen saver or shuffle content periodically if fixed pattern is displayed on the screen.

2. General Description

This specification applies to the 28.6 inch-wide Color TFT-LCD Module G286HAN01.0. The display supports the 1/2 of Full HD - 1920(H) x 540(V) screen format and 16.7M colors (RGB 8-bits data). All input signals are dual channel LVDS interface.

LED driver board is not included. G286HAN01.0 is designed for industrial display applications.

2.1 Display Characteristics

The following items are characteristics summary on the table under 25 °C condition:

ITEMS	Unit	SPECIFICATIONS
Screen Diagonal	[mm]	726.44(28.6")
Active Area	[mm]	698.400 (H) x 196.425 (V)
Pixels H x V		1920(x3) x 540
Pixel Pitch	[um]	363.75 (per one triad) x363.75
Pixel Arrangement		R.G.B. Vertical Stripe
Display Mode		AHVA Mode, Normally Black
White Luminance (Center)	[cd/m ²]	1000
Contrast Ratio		1000: 1
Optical Response Time	[msec]	25
Nominal Input Voltage VDD	[Volt]	+12 V
Power Consumption	[Watt]	44.96 W(Max) = 3.5 W (Cell) +41.46 W (light bar)
Weight	[g]	2,700 (typical)
Physical Size	[mm]	731.46(H) x 229.49(V) x 20.34(D) (Typ)
Electrical Interface		Dual channel LVDS
Support Color		16.7M colors (true 8-bit)
Surface Treatment		Anti-Glare, 3H
Temperature Range		
Operating	[°C]	-10 to +60
Storage (Shipping)	[°C]	-20 to +70
RoHS Compliance		RoHS Compliance

2.2 Optical Characteristics

The optical characteristics are measured under stable conditions at 25°C (Room Temperature):

Item	Unit	Conditions	Min.	Typ.	Max.	Note
White Luminance	[cd/m ²]	I _F = 120mA	800	1000	-	1
Uniformity	%	9 Points	75	80	-	1, 2, 3
Contrast Ratio			800	1000	-	4
Cross talk	%		-	-	1.5	5
Response Time	[msec]	Rising	-	16	-	6
		Falling	-	9	-	
		Rising + Falling	-	25	-	
Viewing Angle	[degree]	Horizontal (Right) CR = 10 (Left)	75	89	-	7
	[degree]		75	89	-	
	[degree]	Vertical (Upper) CR = 10 (Lower)	75	89	-	
	[degree]		75	89	-	
Color / Chromaticity Coordinates (CIE 1931)		Red x	-0.05	0.64	+0.05	
		Red y		0.345		
		Green x		0.324		
		Green y		0.627		
		Blue x		0.152		
		Blue y		0.057		
		White x		0.313		
		White y		0.329		
Color Gamut	%			72	-	

Note 1: Measurement method

Equipment Pattern Generator, Power Supply, Digital Voltmeter, Luminance meter (SR_3 or equivalent)

Aperture 1° with 50cm viewing distance

Test Point Center

Environment < 1 lux

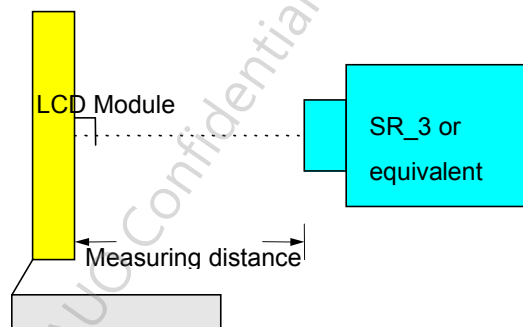

Note 2: Definition of 9 points position. Display active area:

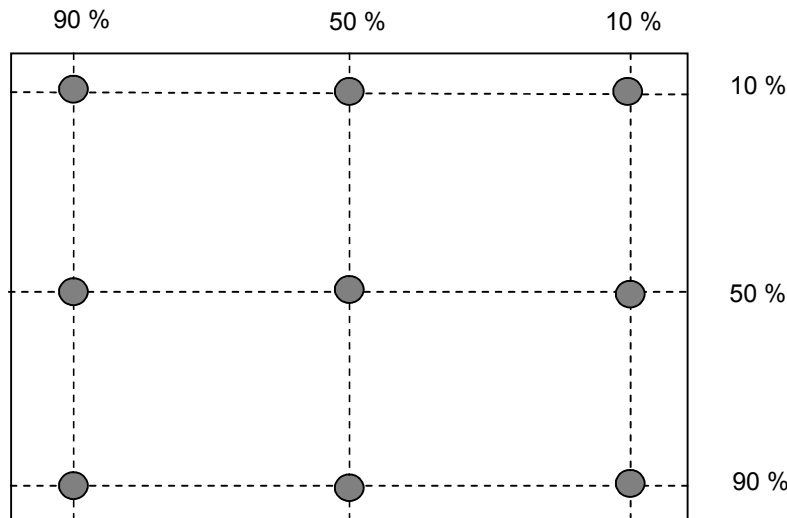

Note 3: The luminance uniformity of 9 points is defined by dividing the minimum luminance values by the maximum test point luminance

$$\delta_{w9} = \frac{\text{Minimum Brightness of nine points}}{\text{Maximum Brightness of nine points}}$$

Note 4 : Definition of contrast ratio (CR):

$$\text{Contrast ratio (CR)} = \frac{\text{Brightness on the "White" state}}{\text{Brightness on the "Black" state}}$$

Note 5 : Definition of cross talk (CT)

$$CT = | YB - YA | / YA \times 100 (\%)$$

Where

YA = Luminance of measured location without gray level 255 pattern (cd/m²)

YB = Luminance of measured location with gray level 255 pattern (cd/m²)

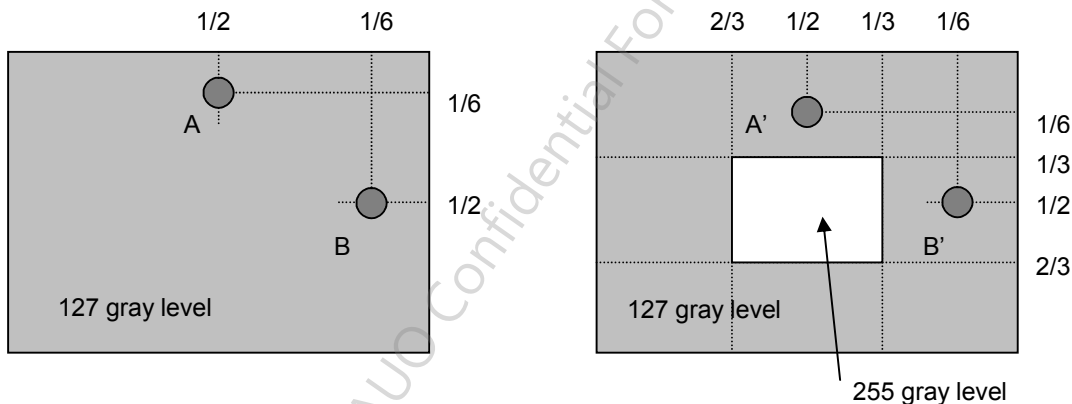

Note 6: Definition of response time:

The output signals of photo detector are measured when the input signals are changed from “White” to “Black” (falling time) and from “Black” to “White” (rising time), respectively. The response time interval is between 10% and 90% of amplitudes. Please refer to the figure as below.

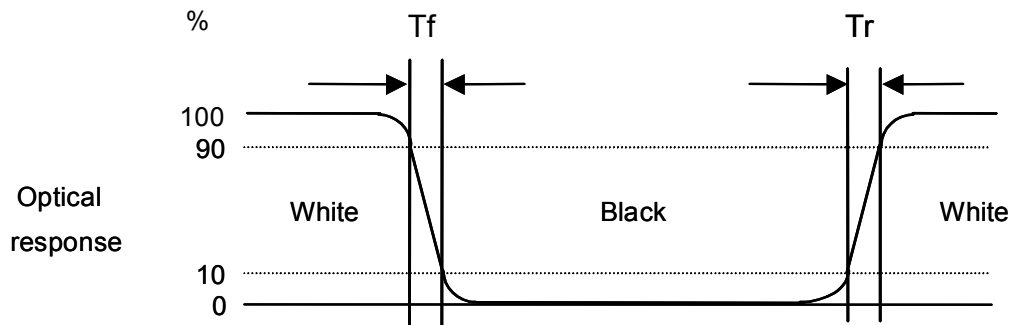

Note 7: Definition of viewing angle

Viewing angle is the measurement of contrast ratio ≥ 10 , at the screen center, over a 180° horizontal and 180° vertical range (off-normal viewing angles). The 180° viewing angle range is broken down as below: 90° (θ) horizontal left and right, and 90° (Φ) vertical high (up) and low (down). The measurement direction is typically perpendicular to the display surface with the screen rotated to its center to develop the desired measurement viewing angle.

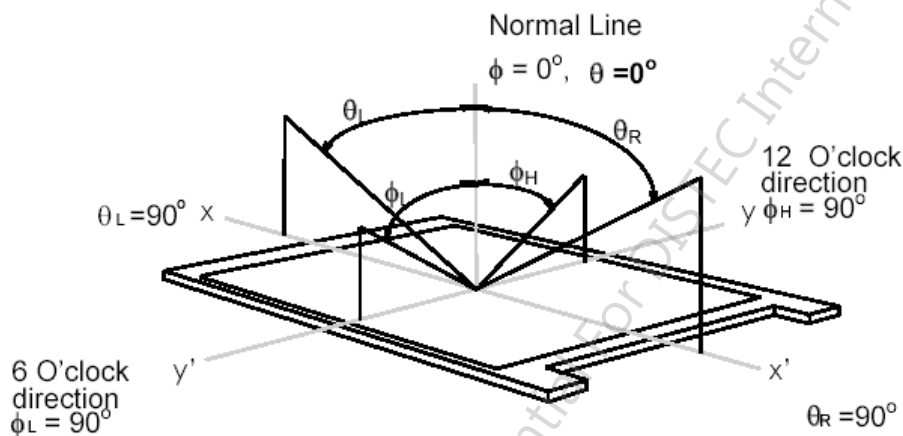

3. Functional Block Diagram

The following diagram shows the functional block of the 28.6 inches wide Color TFT-LCD Module:

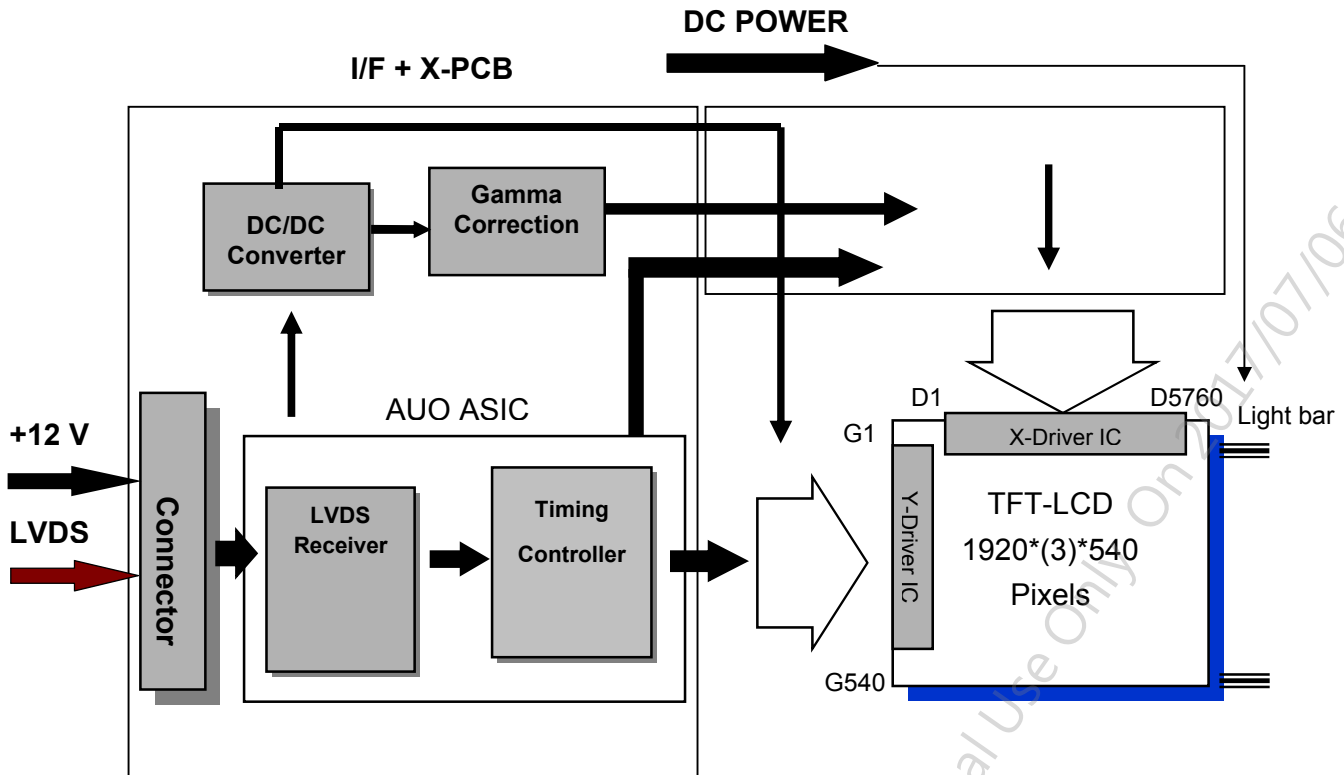

LVDS Connector: JAE SJ11346-FI-RTE51SZ-HF or equivalent.
 LED light bar Connector: ENTERY 3707K-S06N-01L or equivalent.

4. Absolute Maximum Ratings

4.1 TFT LCD Module

Item	Symbol	Min	Max	Unit	Conditions
Logic/LCD Drive Voltage	VDD	-0.3	13.2	[Volt]	Note 1,2

4.2 Backlight Unit

Item	Symbo	Min	Max	Unit	Conditions
LED LB Input Voltage	Vcc	-	43.2	[Volt]	Note 1,2

4.3 Absolute Ratings of Environment

Item	Symbol	Min.	Max.	Unit	Conditions
Operating Temperature	TOP	-10	60	[°C]	Note 3
Operation Humidity	HOP	5	90	[%RH]	
Storage Temperature	TST	-20	70	[°C]	
Storage Humidity	HST	5	90	[%RH]	

Note 1: With in Ta (25°C)

Note 2: Permanent damage to the device may occur if exceeding maximum values

Note 3: For quality performance, please refer to AUO IIS(Incoming Inspection Standard).

5. Electrical Characteristics

5.1 TFT LCD Module

5.1.1 Power Specification

Symbol	Parameter	Min	Typ	Max	Units	Remark
VDD	Logic/LCD Drive Voltage	10.8	12	13.2	[Volt]	± 10%
IDD	VDD Current	-	-	0.29	[A]	VDD= 12V, All White Pattern At 60Hz
Irush	LCD Inrush Current	-	-	3	[A]	Note 1
PDD	VDD Power	-	-	3.50	[Watt]	VDD= 12V, All White Pattern At 60Hz

Note 1: Measurement condition:

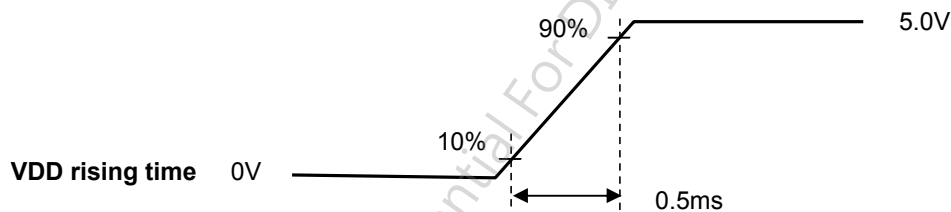
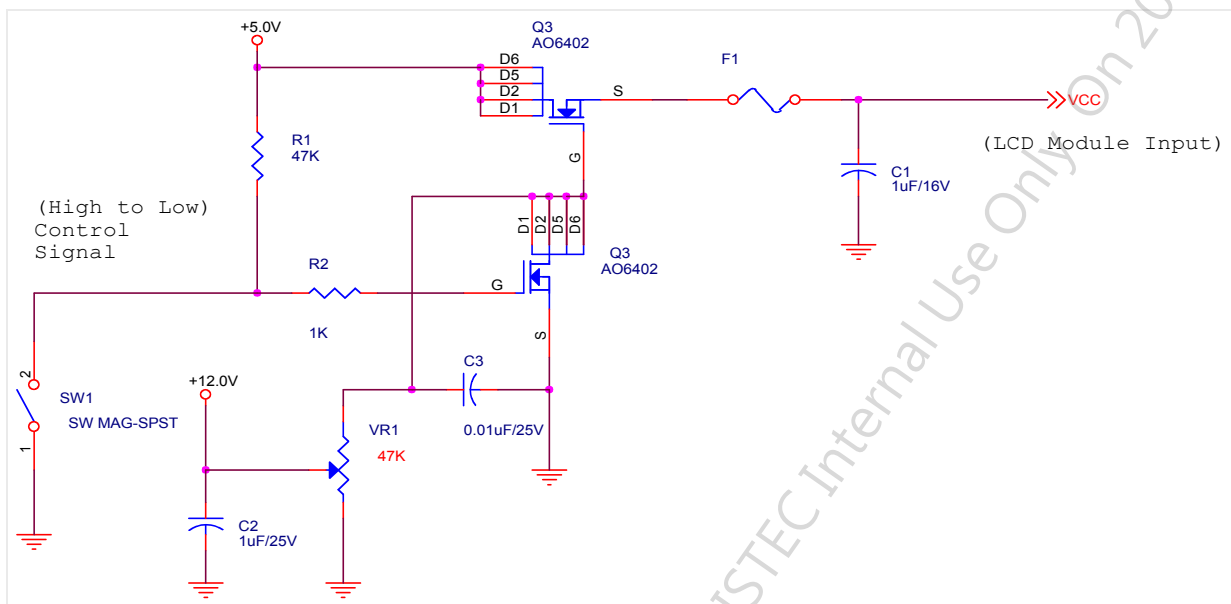

5.1.2 Signal Electrical Characteristics

Input signals shall be low or Hi-Z state when VDD is off.

Symbol	Item	Min	Typ	Max	Units	Remark
VTH	Differential Input High Threshold	-	-	100	[mV]	VCM=1.2V
VTL	Differential Input Low Threshold	-100	-	-	[mV]	VCM=1.2V
VID	Input Differential Voltage	100	-	600	[mV]	
VICM	Differential Input Common Mode Voltage	1.0	1.2	1.5	[V]	VTH/VTL=±100mV

Note: LVDS Signal Waveform.

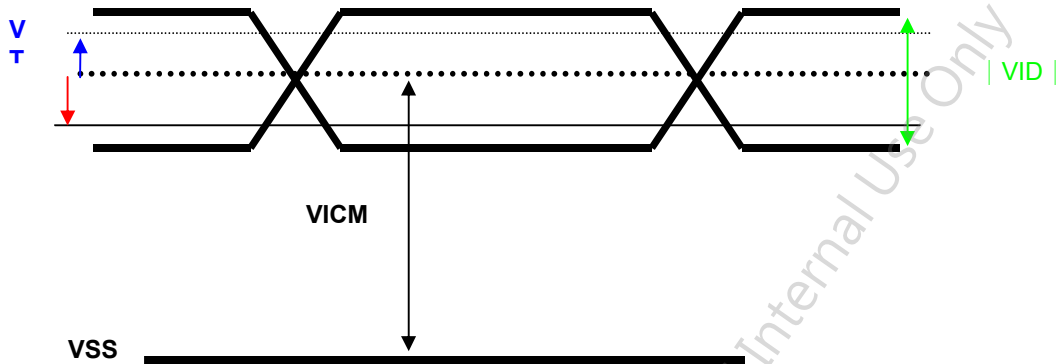

5.2 Backlight Unit

5.2.1 LED Light Bar

Following characteristics are measured under stable condition at 25°C (Room Temperature).

Symbol	Parameter	Min.	Typ.	Max.	Unit	Remark
I_F	LED Forward Current		120		mA	Ta = 25°C
V_F LED	Forward Voltage		38.4	43.2	Volt	Ta = 25°C
P_{LED}	LED Power Consumption (Singal light bar)	-	18.43	20.73	Watt	Ta = 25°C, Note 3 There are two light bars
LTLED	LED Life Time	50,000			Hrs	Ta = 25°C, Note 4

Note 1: Ta means ambient temperature of TFT-LCD module,

Note 2: If module is driven by high current or at high ambient temperature & humidity condition. The operating life will be reduced.

Note 3: LED light bar structure: (2 LB x4 strings/LB x 12pcs / string =96pcs LED)

Note 4: Definition of life time: Brightness becomes to 50% of its original value. The minimum life time of LED unit is on the condition of $I_F = 120$ mA and 25±2°C (Room Temperature).

6. Signal Characteristic

6.1 Pixel Format Image

Following figure shows the relationship of the input signals and LCD pixel format.

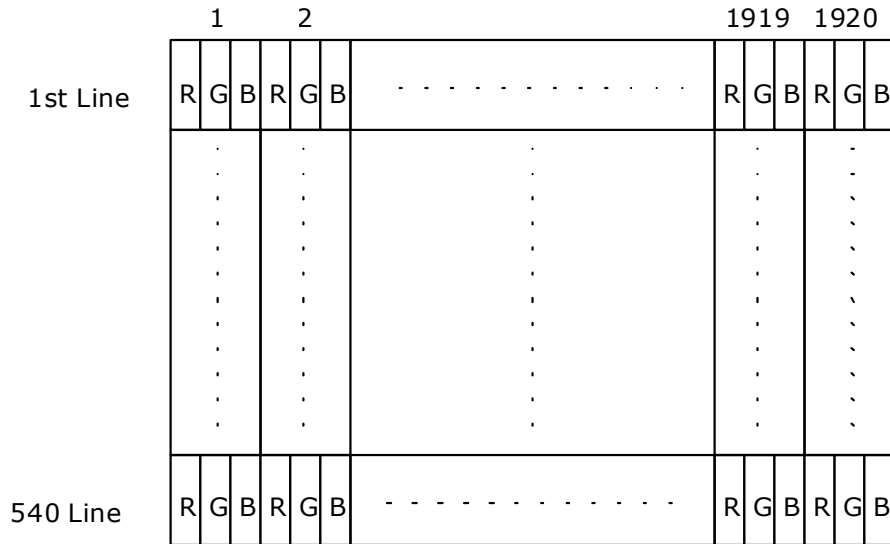

AUO Confidential For DISTEC Internal Use Only On 2017/07/06

6.2 Signal Description

The module using a pair of LVDS receiver SN75LVDS82(Texas Instruments) or compatible. LVDS is a differential signal technology for LCD interface and high speed data transfer device. Transmitter shall be SN75LVDS83(negative edge sampling) or compatible. The first LVDS port transmits odd pixels while the second LVDS port transmits even pixels.

PIN #	SIGNAL NAME	DESCRIPTION
1	N.C.	No Connection
2	N.C.	No Connection
3	N.C.	No Connection
4	N.C.	No Connection
5	N.C.	No Connection
6	N.C.	No Connection
7	SELLVDS	LVDS data format Selection
8	N.C.	No Connection
9	N.C.	No Connection
10	N.C.	No Connection
11	GND	Power Ground
12	RXinO0-	Negative LVDS differential data input (Odd data)
13	RXinO0+	Positive LVDS differential data input (Odd data)
14	RXinO1-	Negative LVDS differential data input (Odd data)
15	RXinO1+	Positive LVDS differential data input (Odd data)
16	RXinO2-	Negative LVDS differential data input (Odd data, H-Sync, V-Sync, DSPTMG)
17	RXinO2+	Positive LVDS differential data input (Odd data, H-Sync, V-Sync, DSPTMG)
18	GND	Power Ground
19	RxOCLKIN-	Negative LVDS differential clock input (Odd clock)
20	RxOCLKIN+	Positive LVDS differential clock input (Odd clock)
21	GND	
22	RXinO3-	Negative LVDS differential data input (Odd data)
23	RXinO3+	Positive LVDS differential data input (Odd data)
24	N.C.	No contact (For AUO test only)
25	N.C.	No contact (For AUO test only)
26	N.C.	No contact (For AUO test only)
27	N.C.	No contact (For AUO test only)
28	RXinE0-	Negative LVDS differential data input (Even data)
29	RXinE0+	Positive LVDS differential data input (Even data)
30	RXinE1-	Negative LVDS differential data input (Even data)



31	RXinE1+	Positive LVDS differential data input (Even data)
32	RXinE2-	Negative LVDS differential data input (Even data)
33	RXinE2+	Positive LVDS differential data input (Even data)
34	GND	
35	RxECLKIN-	Negative LVDS differential clock input (Even clock)
36	RxECLKIN+	Positive LVDS differential clock input (Even clock)
37	GND	
38	RXinE3-	Negative LVDS differential data input (Even data)
39	RXinE3+	Positive LVDS differential data input (Even data)
40	N.C.	No Connection
41	N.C.	No Connection
42	GND	Ground
43	GND	Ground
44	GND	Ground
45	GND	Ground
46	GND	Ground
47	N.C.	No Connection
48	VDD	Power +12V
49	VDD	Power +12V
50	VDD	Power +12V
51	VDD	Power +12V

6.3 The Input Data Format

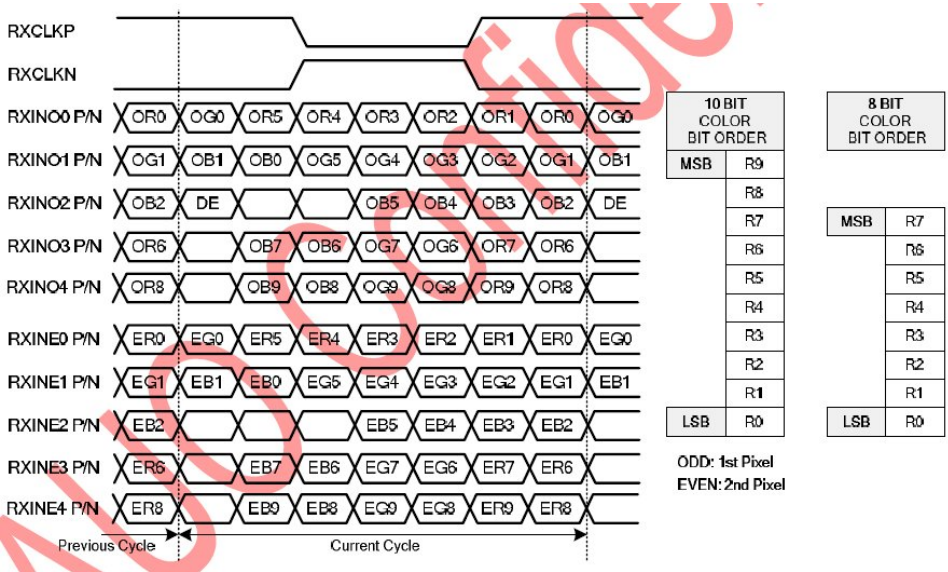

Data Mapping of VESA Format

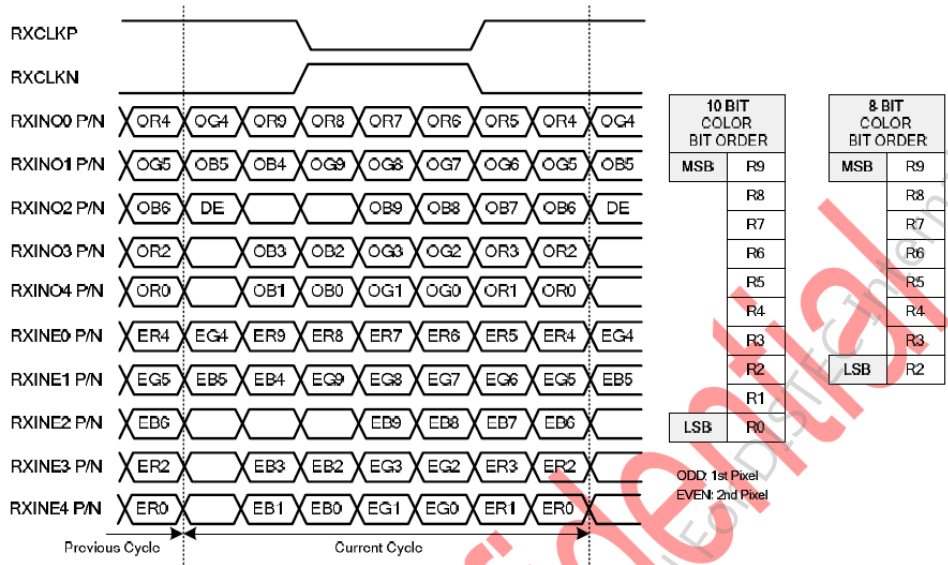

Data Mapping of JEIDA Format

Note1: 8-bits signal input.

Note2: SELLVDS L:JEIDA H:VESA

6.4 Interface Timing

6.4.1 Timing Characteristics

Signal	Item	Symbol	Min	Typ	Max	Unit
Clock	Frequency	$1/T_{\text{Clock}}$	42	45	48	MHz
	Frame Rate	Frequency	$1/T_V$	47	60	63
Vertical Section	Period	T_V	560	585	740	T_{line}
	Active	T_{VD}	540			
	Blanking	T_{VB}	20	45	200	
Horizontal Section	Period	T_H	1030	1283	1325	T_{clock}
	Active	T_{HD}	960			
	Blanking	T_{HB}	70	323	365	

Note 1: DE mode only.

Note 2: The above is as optimized setting

Note 3: Clock min. < Vertical*Horizontal* Frame Rate < Clock max.

6.4.2 Input Timing Diagram

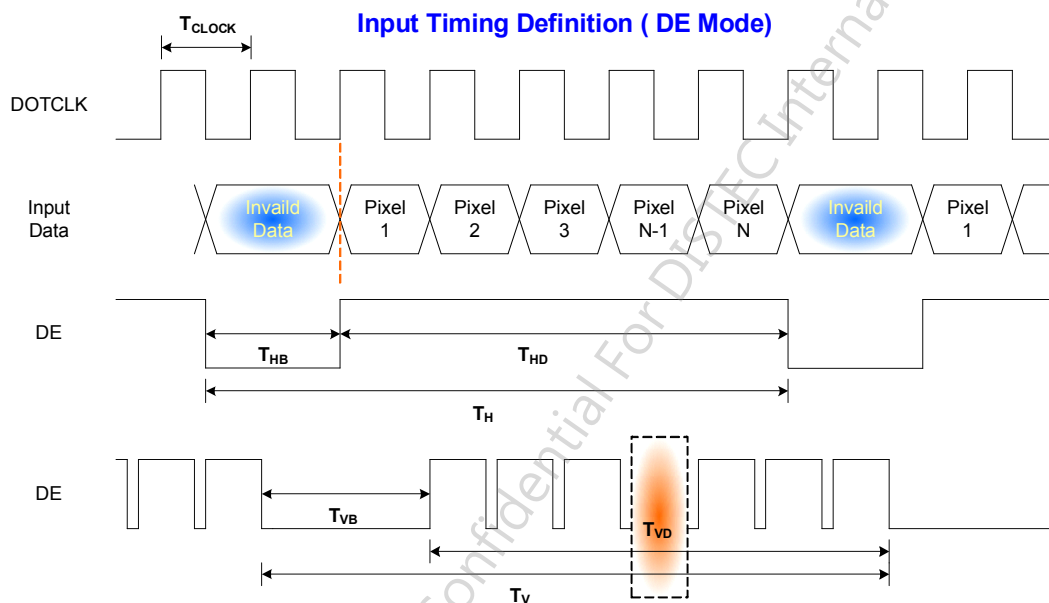

6.5 Power ON/OFF Sequence

VDD power on/off sequence is as follows. Interface signals are also shown in the chart. Signals from any system shall be Hi-Z state or low level when VDD is off.

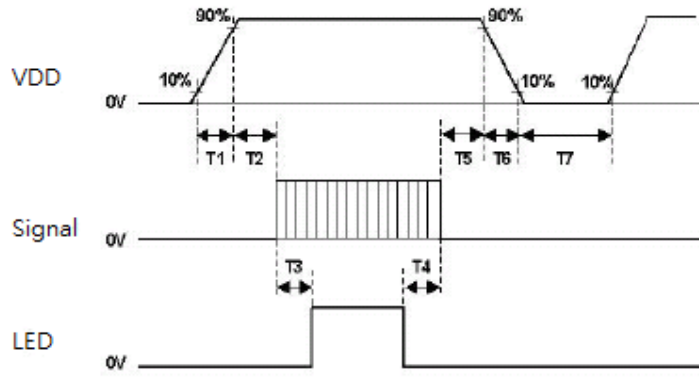

Power Sequence Timing			
Parameter	Value		Units
	Min.	Max.	
T1	0.5	30	ms
T2	10	50	
T3	200	-	
T4	200	-	
T5	0	50	
T6	0	10	
T7	1000	-	

The above on/off sequence should be applied to avoid abnormal function in the display. Please make sure to turn off the power when you plug the cable into the input connector or pull the cable out of the connector.

7. Connector & Pin Assignment

Physical interface is described as for the connector on module. These connectors are capable of accommodating the following signals and will be following components.

7.1 TFT LCD Module: LVDS Connector

Connector Name / Designation	Interface Connector / Interface card
Manufacturer	JAE
Type Part Number	SJ11346-FI-RTE51SZ-HF or equivalent.
Mating Housing Part Number	JAE FI-RE51S-HF or compatible

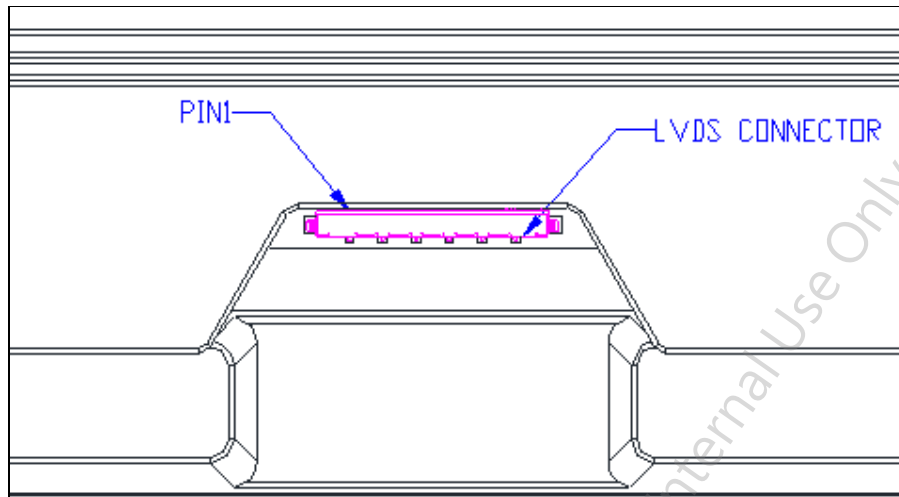

7.2 Backlight Unit: LED Light Bar Connector

Connector Name / Designation	LED Connector
Manufacturer	ENTERY
Connector Model Number	ENTERY 3707K-S06N-01L
Mating Housing Part Number	ENTERY H112K-D06N-21B or compatible

PIN #	SIGNAL NAME	DESCRIPTION
1	VLED+	Positive of LED String
2	VLED+	
3	N1	Negative of LED String
4	N2	
5	N3	
6	N4	

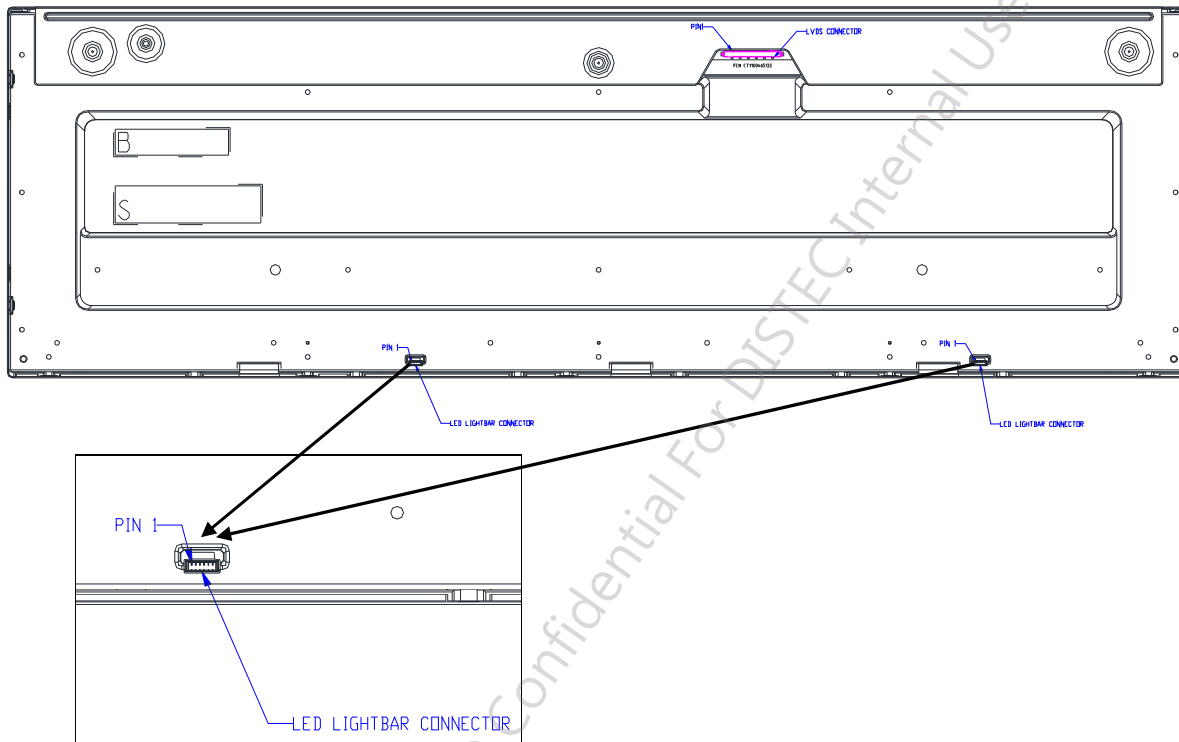

8. Reliability Test

Environment test conditions are listed as following table.

Items	Required Condition	Note
Temperature Humidity Bias (THB)	Ta= 50°C, 80%RH, 300hours	
High Temperature Operation (HTO)	Ta= 60°C, 300hours	
Low Temperature Operation (LTO)	Ta= -10°C, 300hours	
High Temperature Storage (HTS)	Ta= 70°C, 300hours	
Low Temperature Storage (LTS)	Ta= -20°C, 300hours	
Vibration Test (Non-operation)	Acceleration: 1.5 Grms Wave: Random Frequency: 10 - 200 Hz Duration: 30 Minutes each Axis (X, Y, Z)	
Shock Test (Non-operation)	Acceleration: 50 G Wave: Half-sine Active Time: 20 ms Direction: ±X, ±Y, ±Z (one time for each Axis)	
Drop Test	Height: 46 cm, package test	
Thermal Shock Test (TST)	-20°C/30min, 60°C/30min, 100 cycles	
On/Off Test	On/10sec, Off/10sec, 30,000 cycles	
ESD (Electro Static Discharge)	Contact Discharge: ± 8KV, 150pF(330Ω) 1sec, 8 points, 25 times/ point.	1
	Air Discharge: ± 15KV, 150pF(330Ω) 1sec 8 points, 25 times/ point.	
Altitude Test	Operation:10,000 ft Non-Operation:30,000 ft	

Note 1: According to EN61000-4-2, ESD class B: Some performance degradation allowed. No data lost Self-recoverable. No hardware failures.

Note2:

- Water condensation is not allowed for each test items.
- Each test is done by new TFT-LCD module. Don't use the same TFT-LCD module repeatedly for reliability test.
- The reliability test is performed only to examine the TFT-LCD module capability.
- To inspect TFT-LCD module after reliability test, please store it at room temperature and room humidity for 24 hours at least in advance.
- No function failure occurs.

9. Mechanical Characteristics

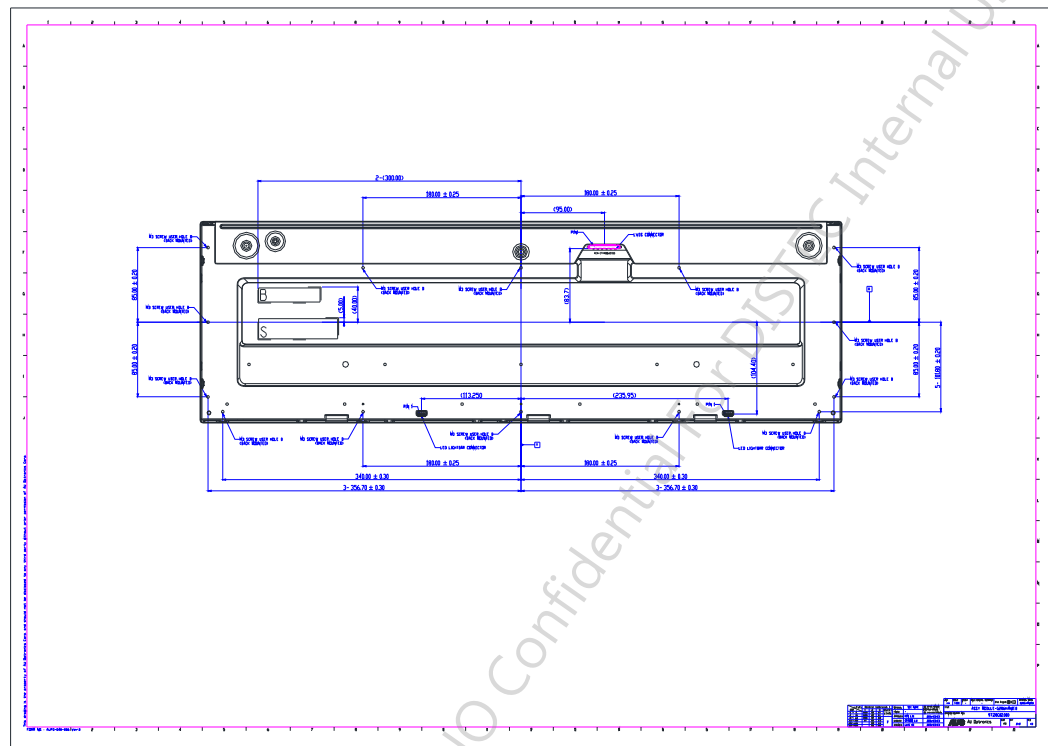
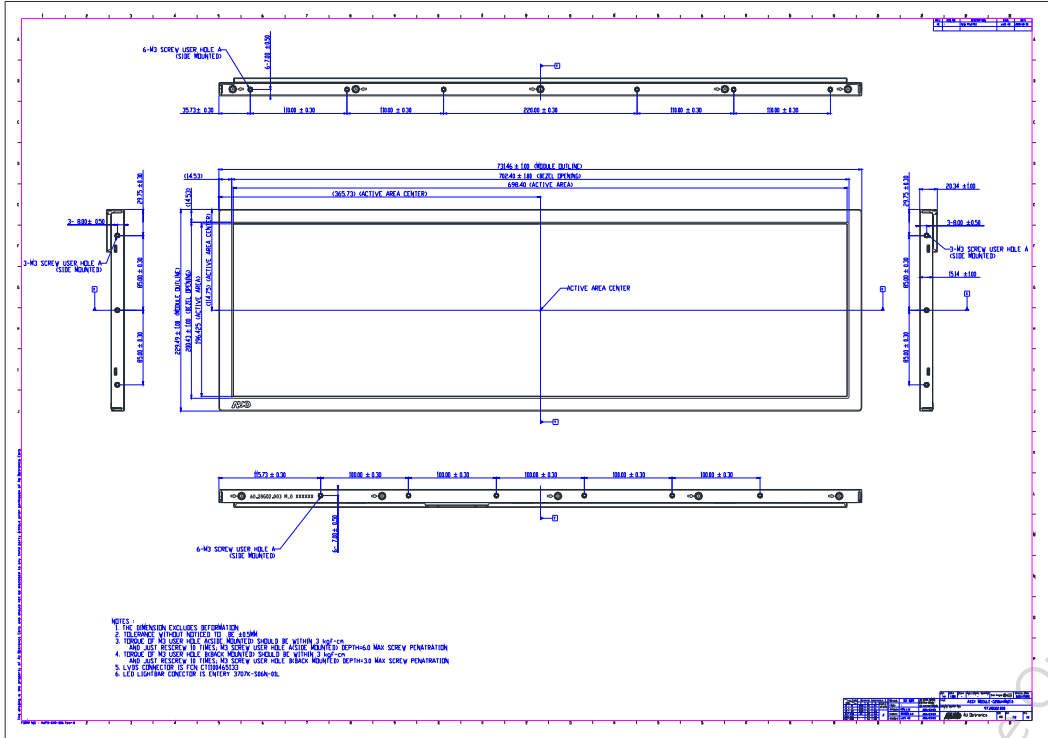

10. Label and Packaging

10.1 Shipping Label (on the rear side of TFT-LCD display)



10.2 Carton Package

- The outside dimension of carton is 810 x 210x 430 (mm).
- 4 pieces per carton box.
- 1*5 boxes per layer. By air, 3 layer / pallet. By sea, refer packing documents. Pallet size (not include carton boxes):
 1150 mm * 840 mm * 135 mm

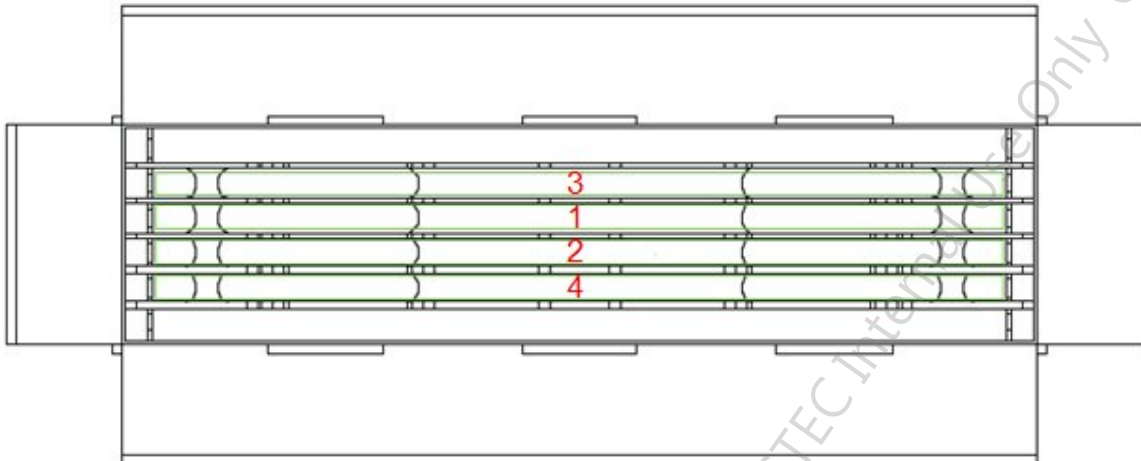



11. Safety

11.1 Sharp Edge Requirements

There will be no sharp edges or comers on the display assembly that could cause injury.

11.2 Materials

11.2.1 Toxicity

There will be no carcinogenic materials used anywhere in the display module. If toxic materials are used, they will be reviewed and approved by the responsible AUO toxicologist.

11.2.2 Flammability

All components including electrical components that do not meet the flammability grade UL94-V1 in the module will complete the flammability rating exception approval process.

The printed circuit board will be made from material rated 94-V1 or better. The actual UL flammability rating will be printed on the printed circuit board.

11.3 Capacitors

If any polarized capacitors are used in the display assembly, provisions will be made to keep them from being inserted backwards.

11.4 National Test Lab Requirement

The display module will satisfy all requirements for compliance to:

UL 1950, First Edition

U.S.A. Information Technology Equipment

Our company network supports you worldwide with offices in Germany, Austria, Switzerland, the UK and the USA. For more information please contact:

Headquarters

Germany



FORTEC Elektronik AG

Lechwiesenstr. 9
86899 Landsberg am Lech

Phone: +49 8191 91172-0
E-Mail: sales@forteca.de
Internet: www.forteca.de

Fortec Group Members

Austria



FORTEC Elektronik AG

Office Vienna

Nuschinggasse 12
1230 Wien

Phone: +43 1 8673492-0
E-Mail: office@fortec.at
Internet: www.fortec.at

Germany



Distec GmbH

Augsburger Str. 2b
82110 Germering

Phone: +49 89 894363-0
E-Mail: info@distec.de
Internet: www.distec.de

Switzerland



ALTRAC AG

Bahnhofstraße 3
5436 Würenlos

Phone: +41 44 7446111
E-Mail: info@altrac.ch
Internet: www.altrac.ch

United Kingdom



Display Technology Ltd.

Osprey House, 1 Osprey Court
Hichingbrooke Business Park
Huntingdon, Cambridgeshire, PE29 6FN

Phone: +44 1480 411600
E-Mail: info@displaytechnology.co.uk
Internet: www.displaytechnology.co.uk

USA



Apollo Display Technologies, Corp.

87 Raynor Avenue,
Unit 1 Ronkonkoma,
NY 11779

Phone: +1 631 5804360
E-Mail: info@apolloDisplays.com
Internet: www.apolloDisplays.com