



DATA DISPLAY GROUP

Datasheet

DD-Group

G150XG01 V3-V555

High Bright 1150cd/m²

UP-02-078

The information contained in this document has been carefully researched and is, to the best of our knowledge, accurate. However, we assume no liability for any product failures or damages, immediate or consequential, resulting from the use of the information provided herein. Our products are not intended for use in systems in which failures of product could result in personal injury. All trademarks mentioned herein are property of their respective owners. All specifications are subject to change without notice.

Content

Revision History.....	3
1. Operating Precautions.....	4
2. General Description.....	5
2.1 Display Characteristics.....	5
2.2 Optical Characteristics.....	6
3. Functional Block Diagram.....	9
4. Absolute Maximum Ratings.....	10
4.1 Absolute Ratings of TFT LCD Module.....	10
4.2 Absolute Ratings of Environment.....	10
5. Electrical Characteristics.....	11
5.1 TFT LCD Module.....	11
5.1.1 Power Specification.....	11
5.1.2 Signal Electrical Characteristics.....	12
5.2 Backlight Specification.....	13
6. Signal Characteristics.....	14
6.1 Pixel Format Image.....	14
6.2 Scanning Direction.....	14
6.3 Signal Description.....	15
6.4 The Input Data Format.....	16
6.4.1 SEL68.....	16
6.5 Interface Timing.....	18
6.5.1 Timing Characteristics.....	18
6.5.2 Timing Diagram.....	18
6.6 Power ON/OFF Sequence.....	19
7. Connector & Pin Assignment.....	20
7.1 TFT-LCD Signal: LVDS Interface Connector.....	20
7.1.1 Connector Illustration.....	21
7.2 LED Backlight Unit.....	22
8. Reliability Test Criteria.....	23
9. Mechanical Characteristics.....	24
9.1 LCM Outline Dimensions (Front View).....	24
9.2 LCM Outline Dimensions (Rear View).....	25
10. Shipping Label.....	26
11. Safety.....	27
11.1 Sharp Edge Requirements.....	27
11.2 Materials.....	27
11.2.1 Toxicity.....	27
11.2.2 Flammability.....	27
11.3 Capacitors.....	27
11.4 National Test Lab Requirement.....	27

Revision History

Version and Date	Page	description
1.0 2012/10/10	All	Preliminary Edition

1. Operating Precautions

- 1) Since front polarizer is easily damaged, pay attention not to scratch it.
- 2) Be sure to turn off power supply when inserting or disconnecting from input connector.
- 3) Wipe off water drop immediately. Long contact with water may cause discoloration or spots.
- 4) When the panel surface is soiled, wipe it with absorbent cotton or other soft cloth.
- 5) Since the panel is made of glass, it may break or crack if dropped or bumped on hard surface.
- 6) Since CMOS LSI is used in this module, take care of static electricity and insure human earth when handling.
- 7) Do not open or modify the Module Assembly.
- 8) Do not press the reflector sheet at the back of the module to any directions.
- 9) In case if a Module has to be put back into the packing container slot after once it was taken out from the container, do not press the center of the LED reflector edge. Instead, press at the far ends of the LED reflector edge softly. Otherwise the TFT Module may be damaged.
- 10) At the insertion or removal of the Signal Interface Connector, be sure not to rotate nor tilt the Interface Connector of the TFT Module.
- 11) After installation of the TFT Module into an enclosure, do not twist nor bend the TFT Module even momentary. At designing the enclosure, it should be taken into consideration that no bending/twisting forces are applied to the TFT Module from outside. Otherwise the TFT Module may be damaged.
- 12) Small amount of materials having no flammability grade is used in the LCD module. The LCD module should be supplied by power complied with requirements of Limited Power Source (IEC60950 or UL1950), or be applied exemption.
- 13) Severe temperature condition may result in different luminance, response time.
- 14) Continuous operating TFT-LCD Module under high temperature environment may accelerate LED light bar exhaustion and reduce luminance dramatically.
- 15) The data on this specification sheet is applicable when TFT-LCD module is placed in landscape position.
- 16) Continuous displaying fixed pattern may induce image sticking. It's recommended to use screen saver or moving content periodically if fixed pattern is displayed on the screen.

2. General Description

G150XG01 V3-V555 is a Color Active Matrix Liquid Crystal Display composed of a TFT-LCD display, a driver circuit, and a backlight system. The screen format is intended to support XGA (1024(H) x 768 (V)) screen and 16.2M (RGB 8-bits) or 262k colors (RGB 6-bits). All input signals are LVDS interface compatible. All design rules of this module can correspond to PSWG standard.

G150XG01 V3-V555 is designed for industrial display applications.

2.1 Display Characteristics

The following items are characteristics summary on the table under 25°C condition:

Items	Unit	Specifications
Screen Diagonal	[mm]	381.0 (15")
Active Area	[mm]	304.128(H) x 228.096(V)
Pixels H x V		1024x2, 768x2 (RGBW)
Pixel Pitch	[mm]	0.297 x 0.297
Pixel Arrangement		R.G.B.W. Rectangle
Display Mode		TN, Normally White
Nominal Input Voltage VDD	[Volt]	3.3 typ.
Typical Power Consumption	[Watt]	9.63 (64 Gray Bar pattern)
Weight	[Grams]	1000g (max.)
Physical Size	[mm]	326.5(H)x 253.5(V) x 13.1(D) (max.)
Electrical Interface		1 channel LVDS
Surface Treatment		Anti-glare, Hardness 3H
Support Color		16.2M / 262K colors
Temperature Range Operating Storage (Non-Operating)	[°C] [°C]	-30 to +85 -30 to +85
RoHS Compliance		RoHS Compliance

2.2 Optical Characteristics

The optical characteristics are measured under stable conditions

Item	Unit	Conditions	Min.	Typ.	Max.	Note
White Luminance	[cd/m ²]	100% Dimming (center point)	1000	1150	-	1
Uniformity	%	9 Points	75	80	-	1, 2, 3
Contrast Ratio			400	700	-	4
Cross talk	%		-	1.2	1.5	5
Response Time	[msec]	Rising	-	5.7		6
	[msec]	Falling	-	2.3		
	[msec]	Raising + Falling	-	8		
Viewing Angle	[degree] [degree]	Horizontal (Right) CR = 10 (Left)	70 70	80 80	- -	7
	[degree] [degree]	Vertical (Upper) CR = 10 (Lower)	50 70	60 80	- -	
Color / Chromaticity Coordinates (CIE 1931)		Red x	0.577	0.627	0.677	
		Red y	0.298	0.348	0.398	
		Green x	0.288	0.338	0.388	
		Green y	0.539	0.589	0.639	
		Blue x	0.100	0.150	0.200	
		Blue y	0.029	0.079	0.129	
		White x	0.263	0.313	0.363	
		White y	0.279	0.329	0.379	
Color Gamut	%		-	60	-	
Gamma Value			-	2.2	-	8

Note 1: Measurement method

Equipment Pattern Generator, Power Supply, Digital Voltmeter, Luminance meter (SR_3 or equivalent)

Aperture 1□ with 50cm viewing distance

Test Point Center

Environment < 1 lux

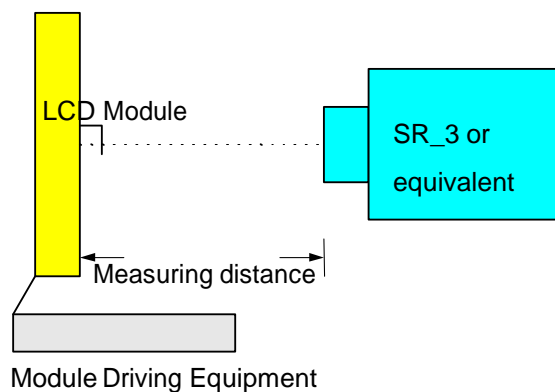

Note 2: Definition of 9 points position (Display active area: 304.128(H) x 228.096(V))

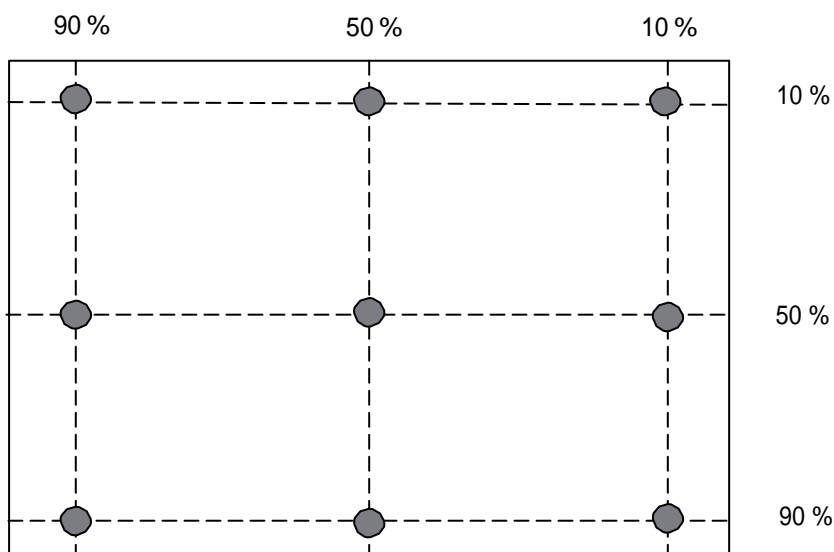

Note 3: The luminance uniformity of 9 points is defined by dividing the minimum luminance values by the maximum test point luminance

$$\delta_{w9} = \frac{\text{Minimum Brightness of nine points}}{\text{Maximum Brightness of nine points}}$$

Note 4 : Definition of contrast ratio (CR):

$$\text{Contrast ratio (CR)} = \frac{\text{Brightness on the "White" state}}{\text{Brightness on the "Black" state}}$$

Note 5 : Definition of cross talk (CT)

$$CT = |YB - YA| / YA \times 100 (\%)$$

Where

YA = Luminance of measured location without gray level 0 pattern (cd/m²)

YB = Luminance of measured location with gray level 0 pattern (cd/m²)

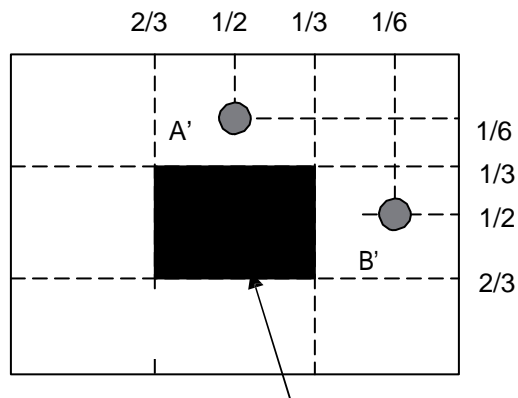
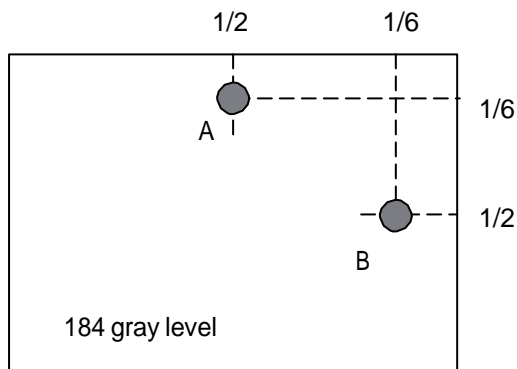

Note 6: Definition of response time:

The output signals of photo detector are measured when the input signals are changed from “White” to “Black” (falling time) and from “Black” to “White” (rising time), respectively. The response time interval is between 10% and 90% of amplitudes. Please refer to the figure as below.

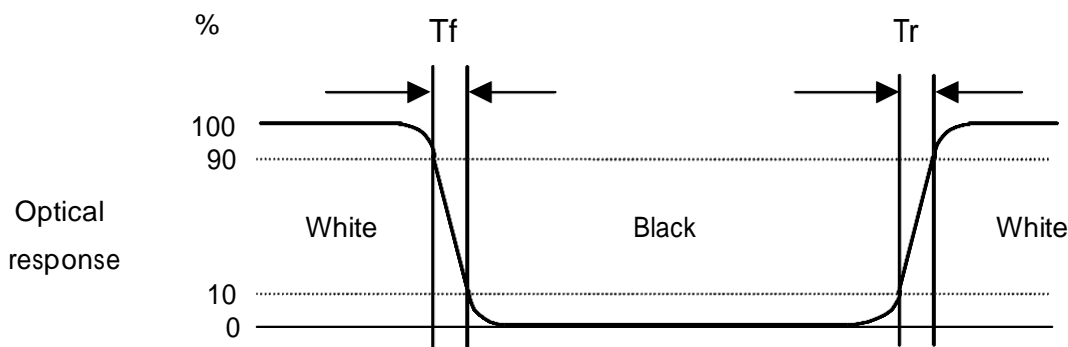

Note 7: Definition of viewing angle

Viewing angle is the measurement of contrast ratio <10, at the screen center, over a 180° horizontal and 180° vertical range (off-normal viewing angles). The 180° viewing angle range is broken down as below: 90° (Φ) horizontal left and right, and 90° (Φ) vertical high (up) and low (down). The measurement direction is typically perpendicular to the display surface with the screen rotated to its center to develop the measurement viewing angle.

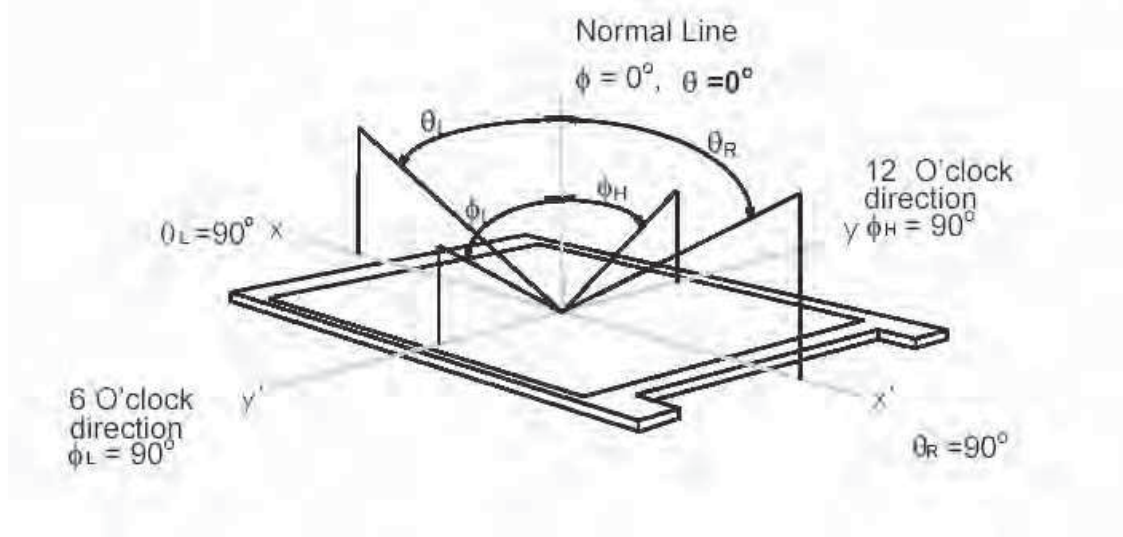

Note 8: Note 8: Definition of Gamma Value

Generally, Gamma Value is defined as the slope of a Gray Level – Luminance curve in log-log space, that is

$$\gamma = d \log(\text{Luminance}) / d \log(\text{Gray Level})$$

The Gamma Value defined in this spec is Linear Regression ($\gamma_1, \gamma_2, \gamma_3, \dots, \gamma_{16}$). γ_1 to γ_{16} are the section gamma of the following 17 sampling points, GL(0), GL(16), GL(32), GL(48), GL(64), GL(80), GL(96), GL(112), GL(128), GL(144), GL(160), GL(176), GL(192), GL(208), GL(224), GL(240) and GL(255), in 8 bits input.

3. Functional Block Diagram

The following diagram shows the functional block of the 15.0 inches color TFT/LCD module:

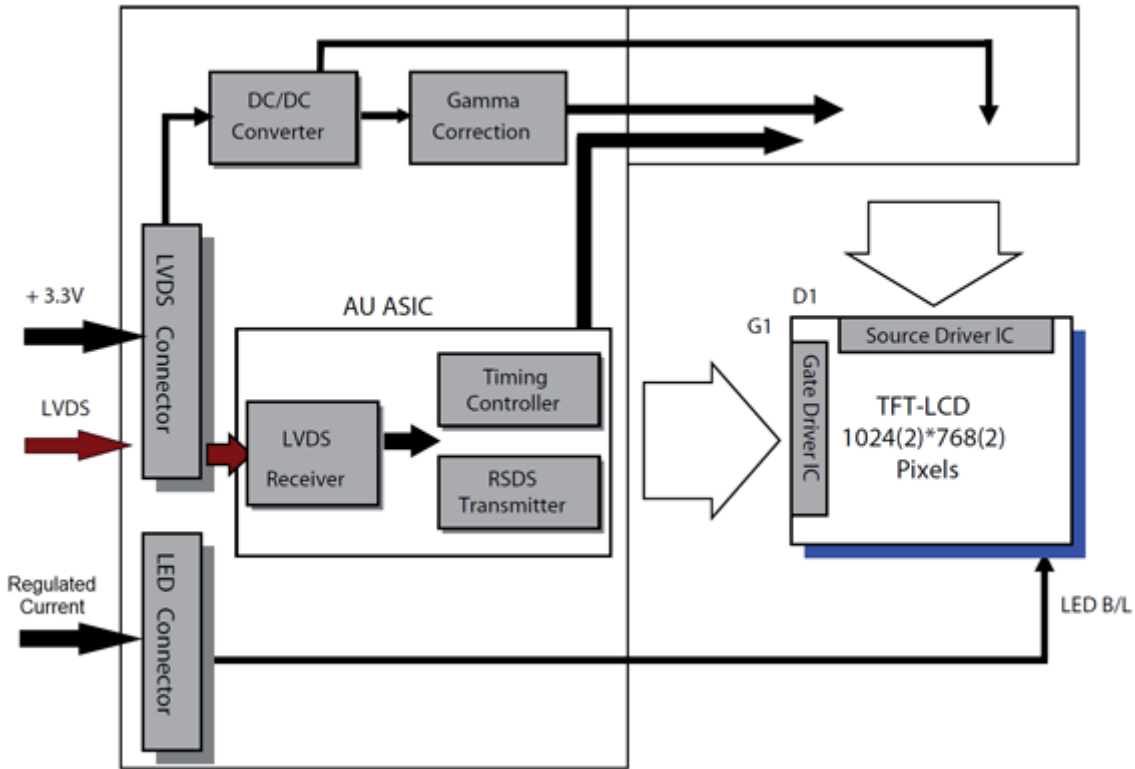

4. Absolute Maximum Ratings

4.1 Absolute Ratings of TFT LCD Module

Item	Symbol	Min	Max	Unit
Logic/LCD Drive Voltage	Vin	- 0.3	+3.6	[Volt]

4.2 Absolute Ratings of Environment

Item	Symbol	Min	Max	Unit
Operating Temperature	TOP	-30	+85	[°C]
Operation Humidity	HOP	8	90	[%RH]
Storage Temperature	TST	-30	+85	[°C]
Storage Humidity	HST	8	90	[%RH]

Note Maximum Wet-Bulb should be 39°C and no condensation.

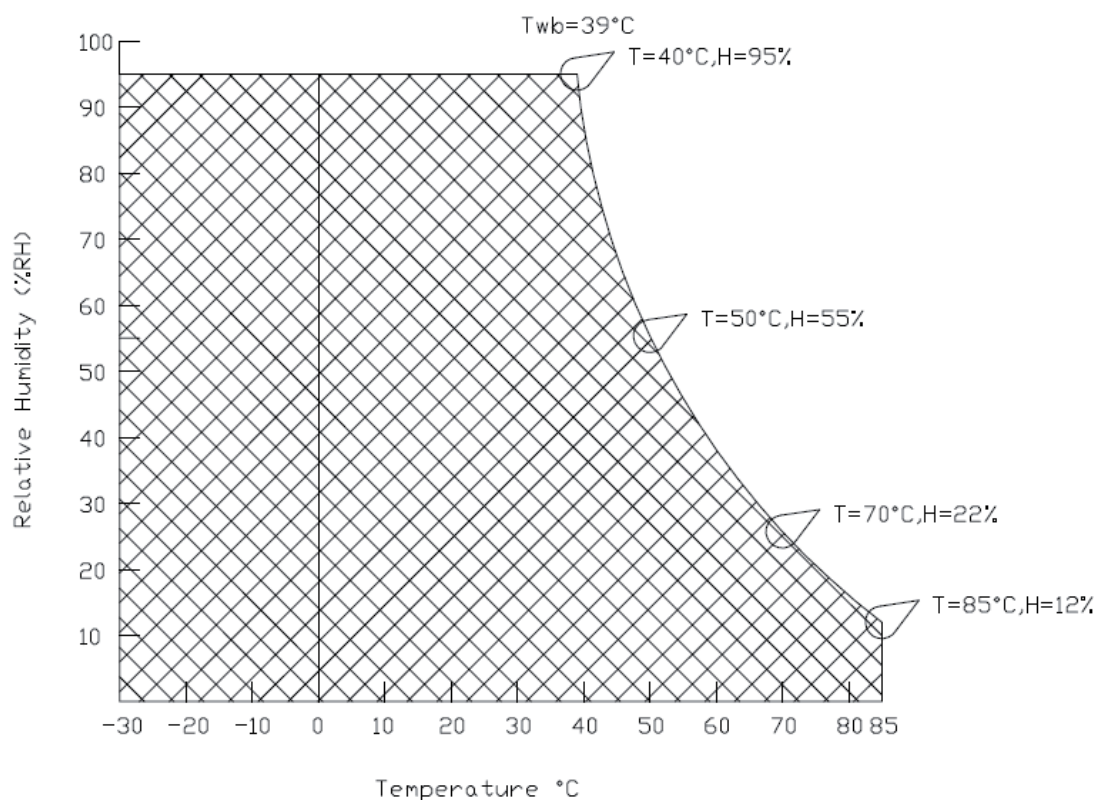

5. Electrical Characteristics

5.1 TFT LCD Module

5.1.1 Power Specification

Symbol	Parameter	Min.	Typ.	Max.	Unit	Remark
VDD	Logic/LCD Drive Voltage	3.0	3.3	3.6	[Volt]	± 10%
IDD	VDD Current	-	700	840	[mA]	64 Gray Bar Pattern (VDD=3.3V, at 60Hz)
Irush	LCD Inrush Current	-	-	3	[A]	Note 1
PDD	VDD Power	-	2.31	2.77	[Watt]	64 Gray Bar Pattern (VDD=3.3V, at 60Hz)

Note 1: Measurement condition:

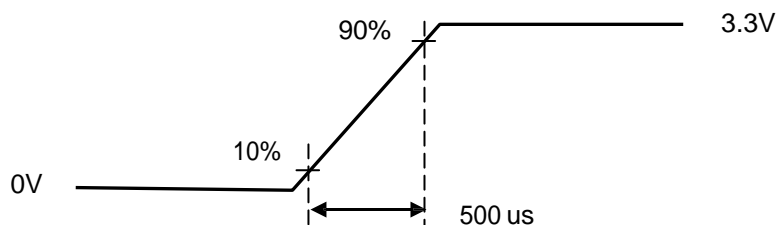
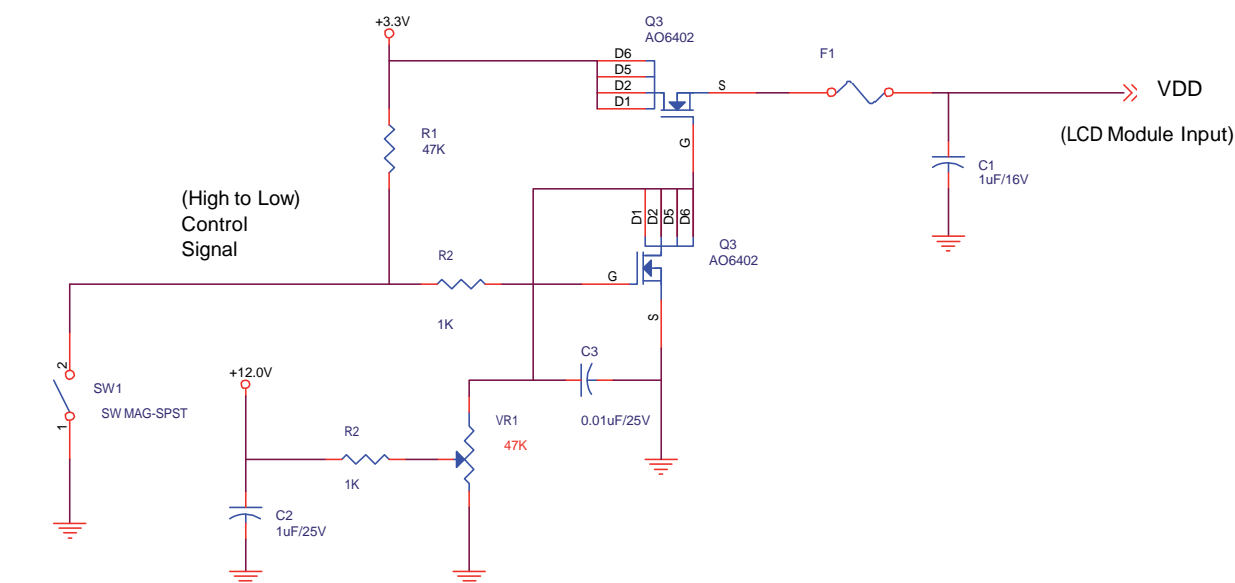

VDD rising time

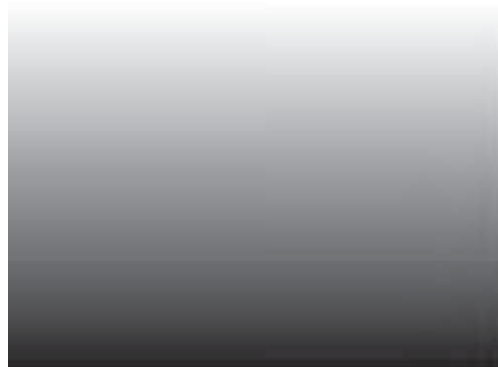

64 Gray pattern

5.1.2 Signal Electrical Characteristics

Input signals shall be low or Hi-Z state when VDD is off.

Symbol	Item	Min.	Typ.	Max.	Unit	Remark
VTH	Differential Input High Threshold	-	-	100	[mV]	VCM=1.2V
VTL	Differential Input Low Threshold	100	-	-	[mV]	VCM=1.2V
VID	Input Differential Voltage	100	400	600	[mV]	
VICM	Differential Input Common Mode Voltage	1.15	1.2	1.45	[V]	VTH/VTL±_100mV

Note: LVDS Signal Waveform.

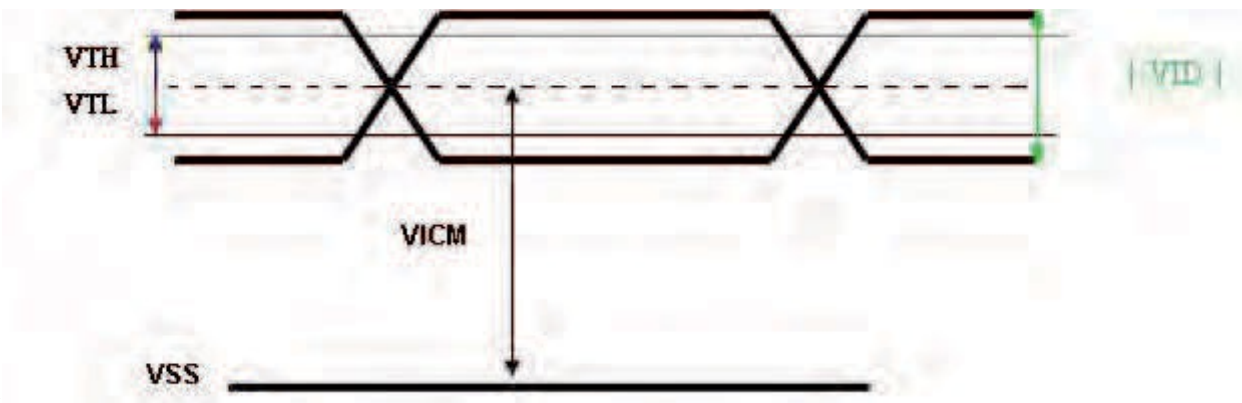

5.2 Backlight Specification

The backlight consists of one LED rail.

ITEM	SYMBOL	MIN	TYP.	MAX.	UNIT	Remarks
LED Forward Voltage	VL	--	8.3	--	V	*1), IL = 1.4A
LED Forward Current	IL	--	1400	--	mA	*2)
Power Consumption	WL	--	11.6	--	W	IL = 1.4A
Backlight Lifetime	BL	50,000	--	--	Hr	*3), *4)

*1) VL is specified as the sum of the white LED forward voltages.

*2) LEDs are best powered using a constant current source. To avoid chromaticity shifts while dimming use pulse-width modulation (PWM) techniques.

*3) Backlight lifetime is defined as the time when brightness becomes 50% of the initial value.

*4) The lifetime of the backlight is dependent of the ambient temperature. The lifetime will decrease under temperatures above 80°C unless LED forward current is reduced accordingly.

*5) LED forward current derating curve:

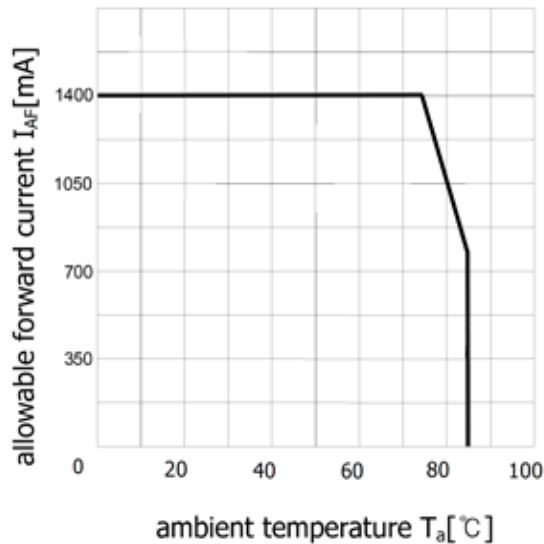

6*) Recommended backlight power supply data

PART NUMBER	MANUFACTURER
SmartLED 2x700mA 1 x IN-50-012 – analog 1 x IN-51-012 – PWM 1 x Cable CBL-390A	Apollo Display Technologies Corp.

6. Signal Characteristics

6.1 Pixel Format Image

Following figure shows the relationship of the input signals and LCD pixel format.

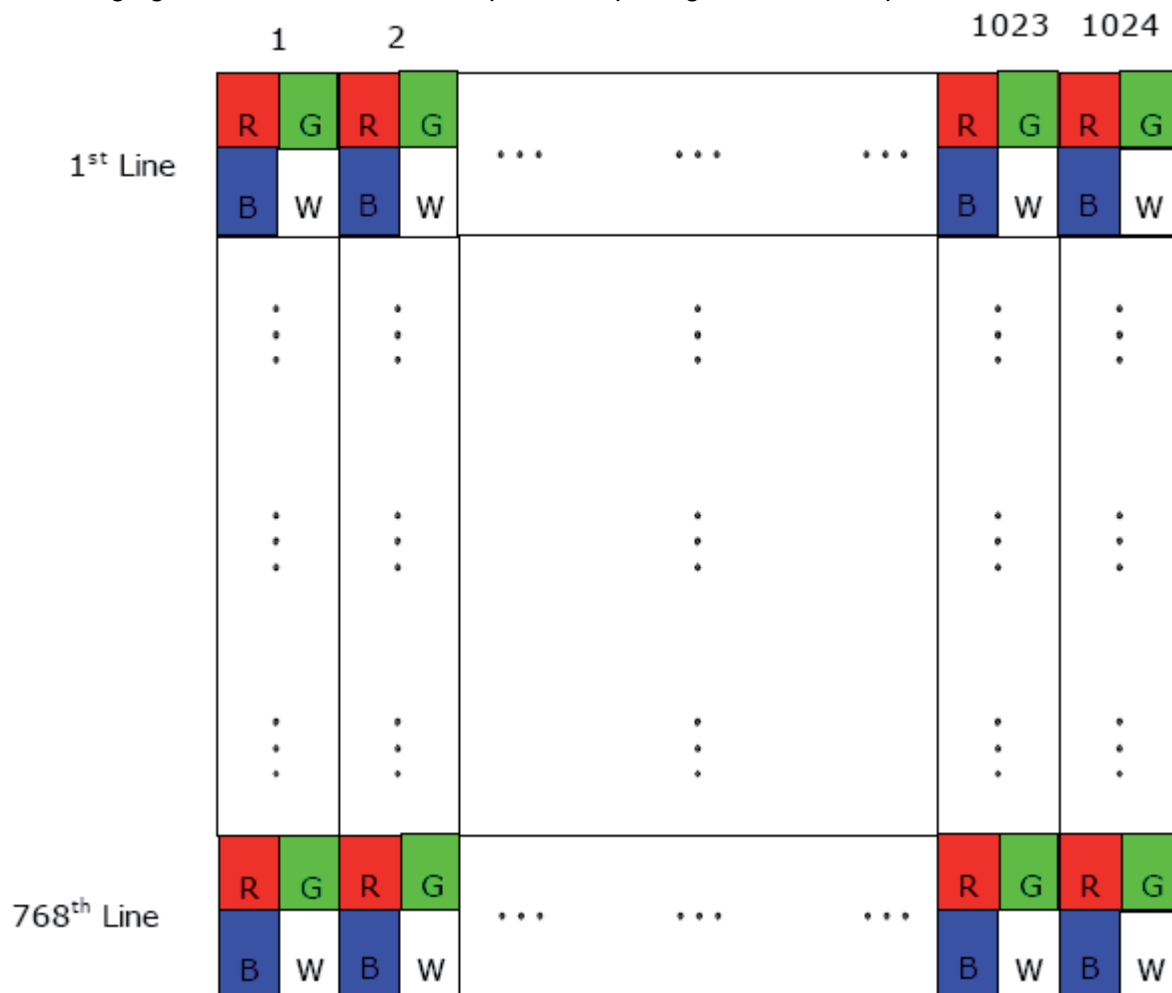

6.2 Scanning Direction

The following figures show the image seen from the front view. The arrow indicates the direction of scan.

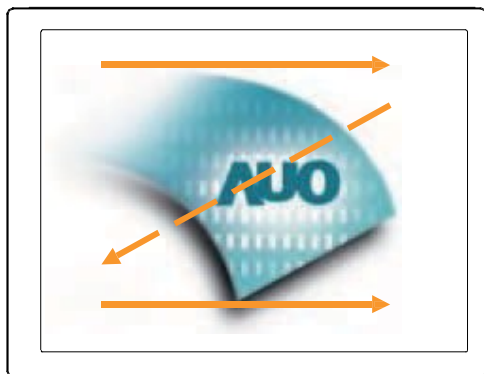

Fig. 1 Normal scan (Pin4, REV = Low or NC)

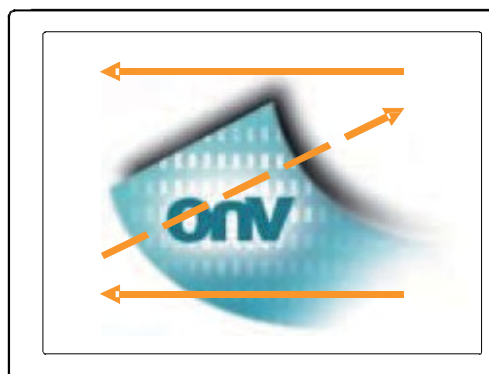

Fig. 2 Reverse scan (Pin4, REV = High)

6.3 Signal Description

The module using a pair of LVDS receiver SN75LVDS82(Texas Instruments) or compatible. LVDS is a differential signal technology for LCD interface and high speed data transfer device. Transmitter shall be SN75LVDS83(negative edge sampling) or compatible. The first LVDS port(RxOxxx) transmits odd pixels while the second LVDS port(RxExxx) transmits even pixels.

Input Signal Interface		
Pin No.	Symbol	Description
1	VDD	Power Supply, 3.3V (typical)
2	VDD	Power Supply, 3.3V (typical)
3	GND	Ground
4	REV	Reverse Scan [H: Enable; L/NC: Disable] *Note1,3
5	Rin0-	- LVDS differential data input
6	Rin0+	+ LVDS differential data input
7	GND	Ground
8	Rin1-	- LVDS differential data input
9	Rin1+	+ LVDS differential data input
10	GND	Ground
11	Rin2-	- LVDS differential data input
12	Rin2+	+ LVDS differential data input
13	GND	Ground
14	ClkIN-	- LVDS differential clock input
15	ClkIN+	+ LVDS differential clock input
16	GND	Ground
17	Rin3-	- LVDS differential data input *Note2
18	Rin3+	+ LVDS differential data input *Note2
19	NC/GND	Reserved for AUO internal test. Please set it as NC or Ground.
20	SEL68	Selection for 6 bits/8bits LVDS data input[H/NC: 6bits, L: 8bits] *Note1,3

Note 1: Input signals shall be in low status when VDD is off.

Note 2: For 6bits input mode, pin 17 and pin 18 must be floated.

Note 3: High stands for "3.3V", Low stands for "0V"; NC stands for "No Connection".

6.4 The Input Data Format

6.4.1 SEL68

SEL68 = "High" or "NC" for 6 bits LVDS Input

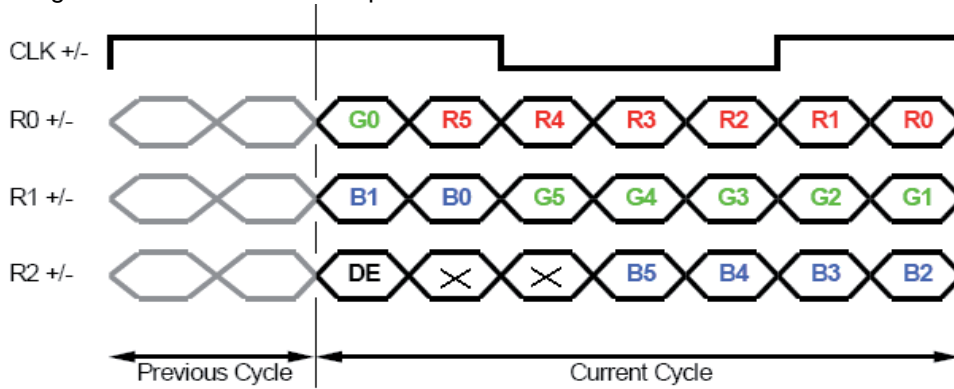

SEL68 = "Low" for 8 bits LVDS Input

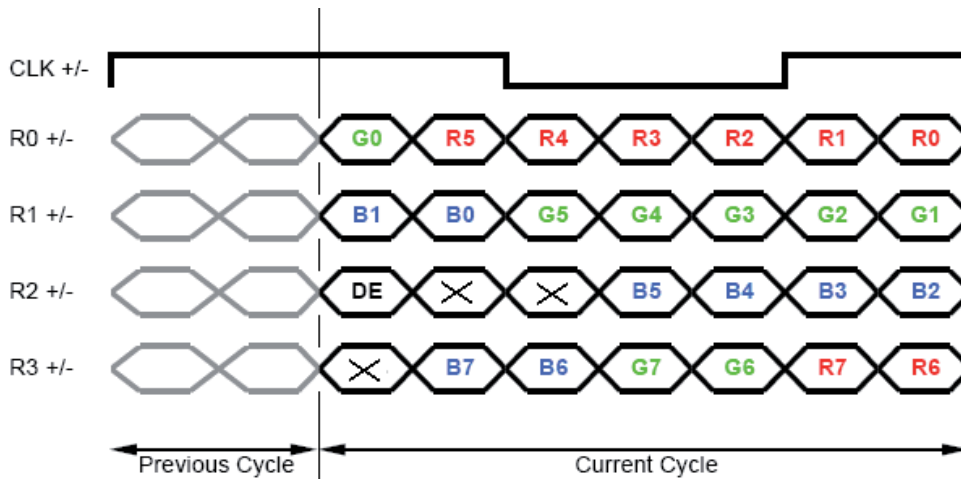



Signal Name	Description	Remark
R7 R6 R5 R4 R3 R2 R1 R0	Red Data 7 Red Data 6 Red Data 5 Red Data 4 Red Data 3 Red Data 2 Red Data 1 Red Data 0	Red-pixel Data For 6Bits LVDS input MSB: R5 ; LSB: R0 For 8Bits LVDS input MSB: R7 ; LSB: R0
G7 G6 G5 G4 G3 G2 G1 G0	Green Data 7 Green Data 6 Green Data 5 Green Data 4 Green Data 3 Green Data 2 Green Data 1 Green Data 0	Green-pixel Data For 6Bits LVDS input MSB: G5 ; LSB: G0 For 8Bits LVDS input MSB: G7 ; LSB: G0
B7 B6 B5 B4 B3 B2 B1 B0	Blue Data 7 Blue Data 6 Blue Data 5 Blue Data 4 Blue Data 3 Blue Data 2 Blue Data 1 Blue Data 0	Blue-pixel Data For 6Bits LVDS input MSB: B5 ; LSB: B0 For 8Bits LVDS input MSB: B7 ; LSB: B0
RxCLKIN L	VDS Data Clock	The typical frequency is 65MHz. The signal is used to strobe the pixel data and DE signals. All pixel data shall be valid at the falling edge when the DE signal is high.
DE	Data Enable Signal	When the signal is high, the pixel data shall be valid to be displayed.

Note: Output signals from any system shall be low orHi-Z state when VDD is off.

6.5 Interface Timing

6.5.1 Timing Characteristics

Signal	Parameter	Symbol	Min.	Typ.	Max.	Unit	
Clock Timing	Clock frequency	$1/T_{\text{Clock}}$	50	65	80	MHz	
Vsync Timing	Vertical Section	Period	T_V	776	806	1023	T_{Line}
		Active	T_{VD}	-	768	-	
		Blanking	T_{VB}	8	38	255	
Hsync Timing	Horizontal Section	Period	T_H	1074	1344	2047	T_{Clock}
		Active	T_{HD}	-	1024	-	
		Blanking	T_{HB}	50	320	1023	
Frame Rate		F	50	60	75	Hz	

Note: DE mode only.

Note: Typical value refer to VESA STANDARD

6.5.2 Timing Diagram

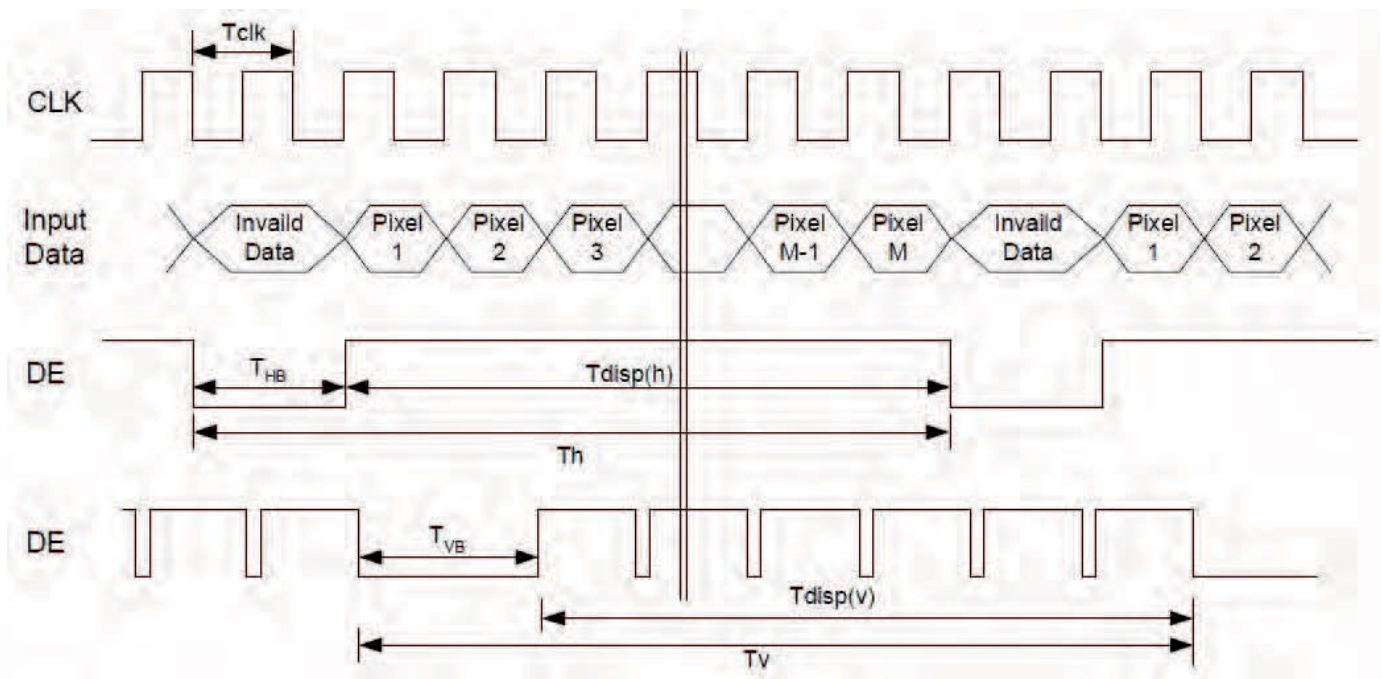

6.6 Power ON/OFF Sequence

VDD power and LED on/off sequence is as follows. Interface signals are also shown in the chart. Signals from any system shall be Hi-Z state or low level when VDD is off.

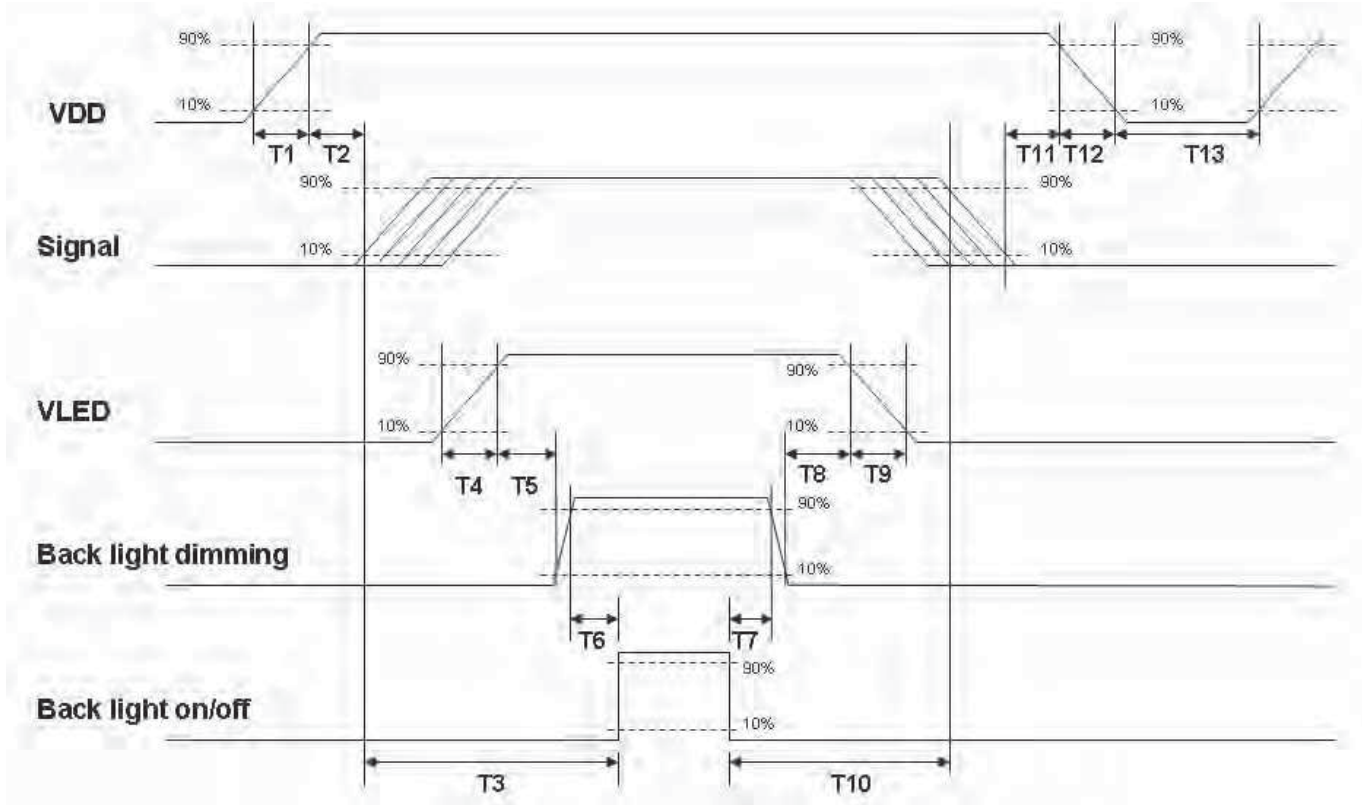

Power ON/OFF sequence timing

Parameter	Value			Units
	Min.	Typ.	Max.	
T1	0.5	-	10	[ms]
T2	30	40	50	[ms]
T3	200	-	-	[ms]
T4	0.5	-	10	[ms]
T5	10	-	-	[ms]
T6	10	-	-	[ms]
T7	0	-	-	[ms]
T8	10	-	-	[ms]
T9	-	-	10	[ms]
T10	110	-	-	[ms]
T11	0	16	50	[ms]
T12	-	-	10	[ms]
T13	1000	-	-	[ms]

The above on/off sequence should be applied to avoid abnormal function in the display. Please make sure to turn off

7. Connector & Pin Assignment

Physical interface is described as for the connector on module. These connectors are capable of accommodating the following signals and will be following components.

7.1 TFT-LCD Signal: LVDS Interface Connector

Connector Name / Designation	Signal Connector
Manufacturer	STM or compatible
Type Part Number	MSB240420-E
Mating Housing Part Number	P240420 or compatible

Pin#	Signal Name	Pin#	Signal Name
1	VDD	2	VDD
3	GND	4	REV
5	Rin0-	6	Rin0+
7	GND	8	Rin1-
9	Rin1+	10	GND
11	Rin2-	12	Rin2+
13	GND	14	ClkIN-
15	ClkIN+	16	GND
17	Rin3-	18	Rin3+
19	NC/GND	20	SEL68

7.1.1 Connector Illustration

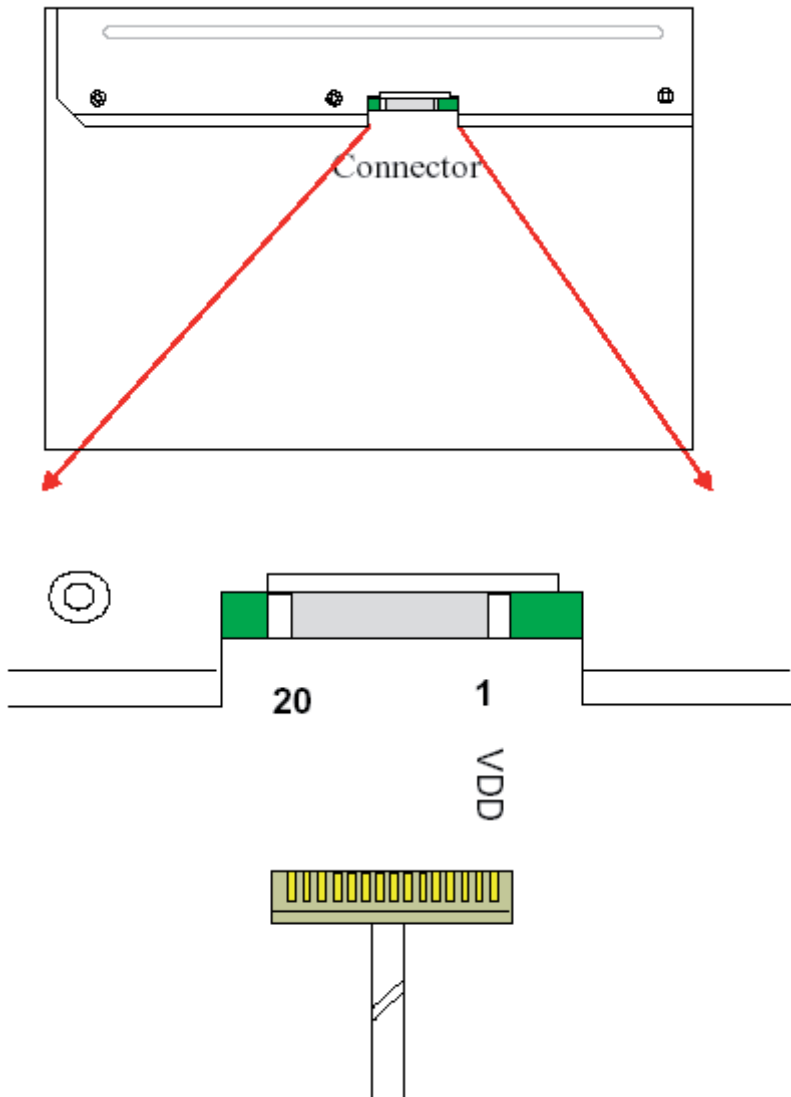

7.2 LED Backlight Unit

Connector Name / Designation	Lamp Connector
Manufacturer	Molex
Connector Model Number	22-01-3027
Mating Model Number	22-05-3021

Pin No.	symbol	description	Color
Pin1	HV	Input Power	Red
Pin2	LV	GND	Black

VL = HV – LV

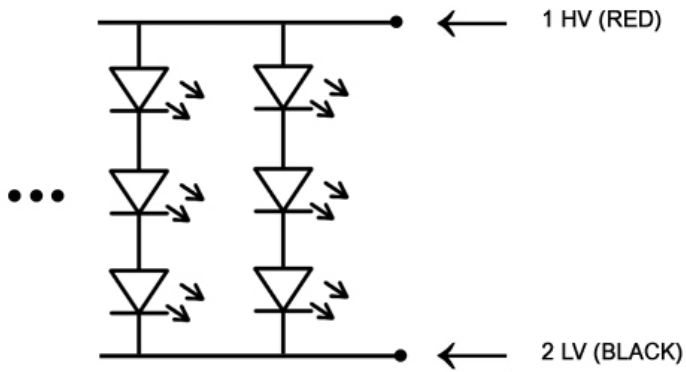

8. Reliability Test Criteria

Items	Required Condition	Note
Temperature Humidity Bias	50°C / 80%, 300 hours	
High Temperature Operation	50°C, 300 hours	
Low Temperature Operation	-30°C, 300 hours	
Hot Storage	85°C, 300 hours	
Cold Storage	-30°C, 300 hours	
Thermal Shock Test	-20°C / 30 min, 50°C / 30 min, 100 cycles	
Shock Test (Non-Operating)	50G, 20ms, Half-sine wave, (±X, ±Y, ±Z)	
Vibration Test (Non-Operating)	1.5G, (10~200Hz, P-P) 30 mins/axis (X, Y, Z)	
On/off test	On/10 sec, Off/10 sec, 30,000 cycles	
ESD	Contact Discharge: ± 8KV, 150pF(330Ω) 1sec, 8 points, 25 times/point Air Discharge: ± 15KV, 150pF(330Ω) 1sec, 8 points, 25 times/point	Note 1

Note1: According to EN61000-4-2, ESD class B: Some performance degradation allowed. No data lost.

Self-recoverable. No hardware failures.

9. Mechanical Characteristics

9.1 LCM Outline Dimensions (Front View)

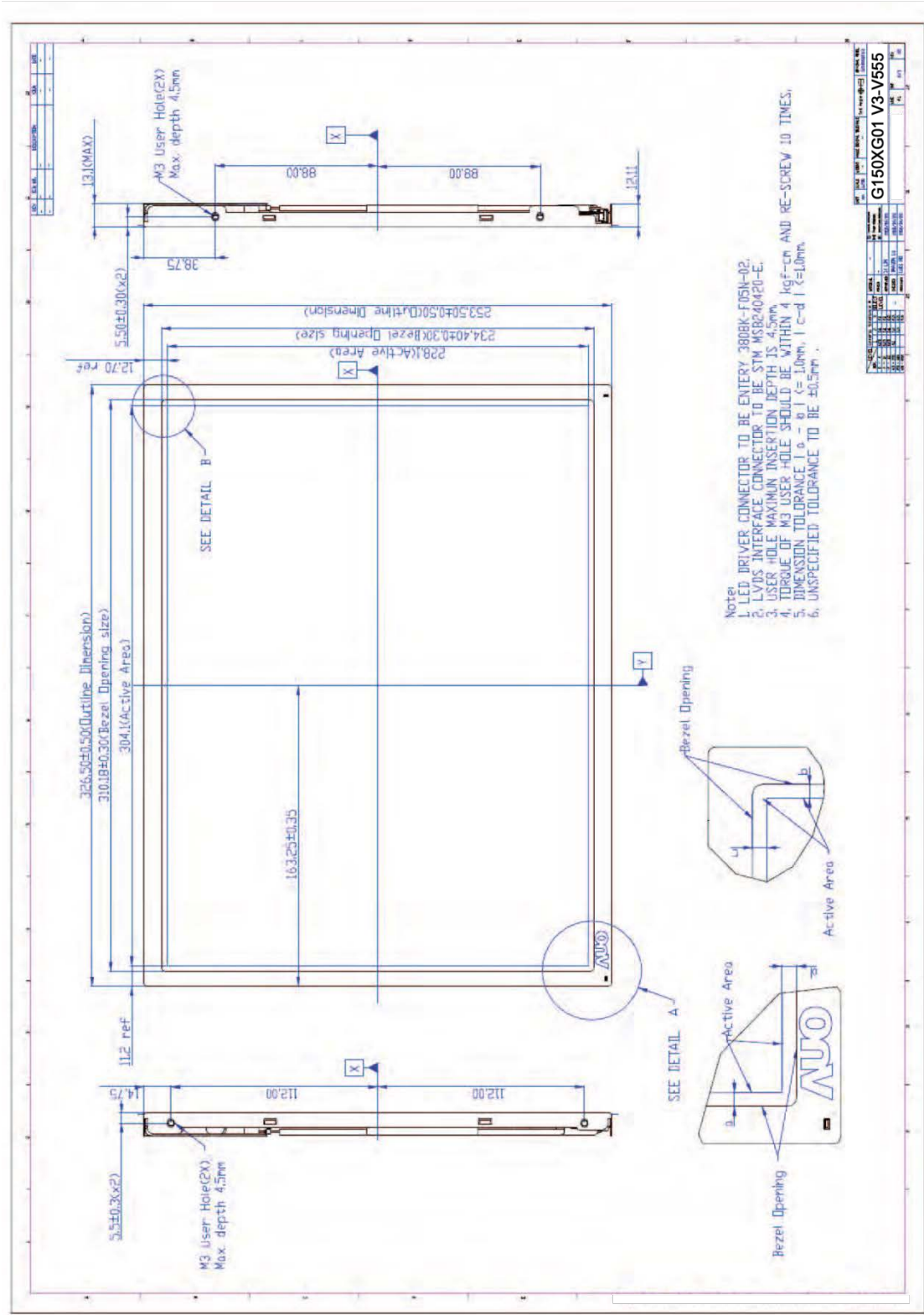

9.2 LCM Outline Dimensions (Rear View)

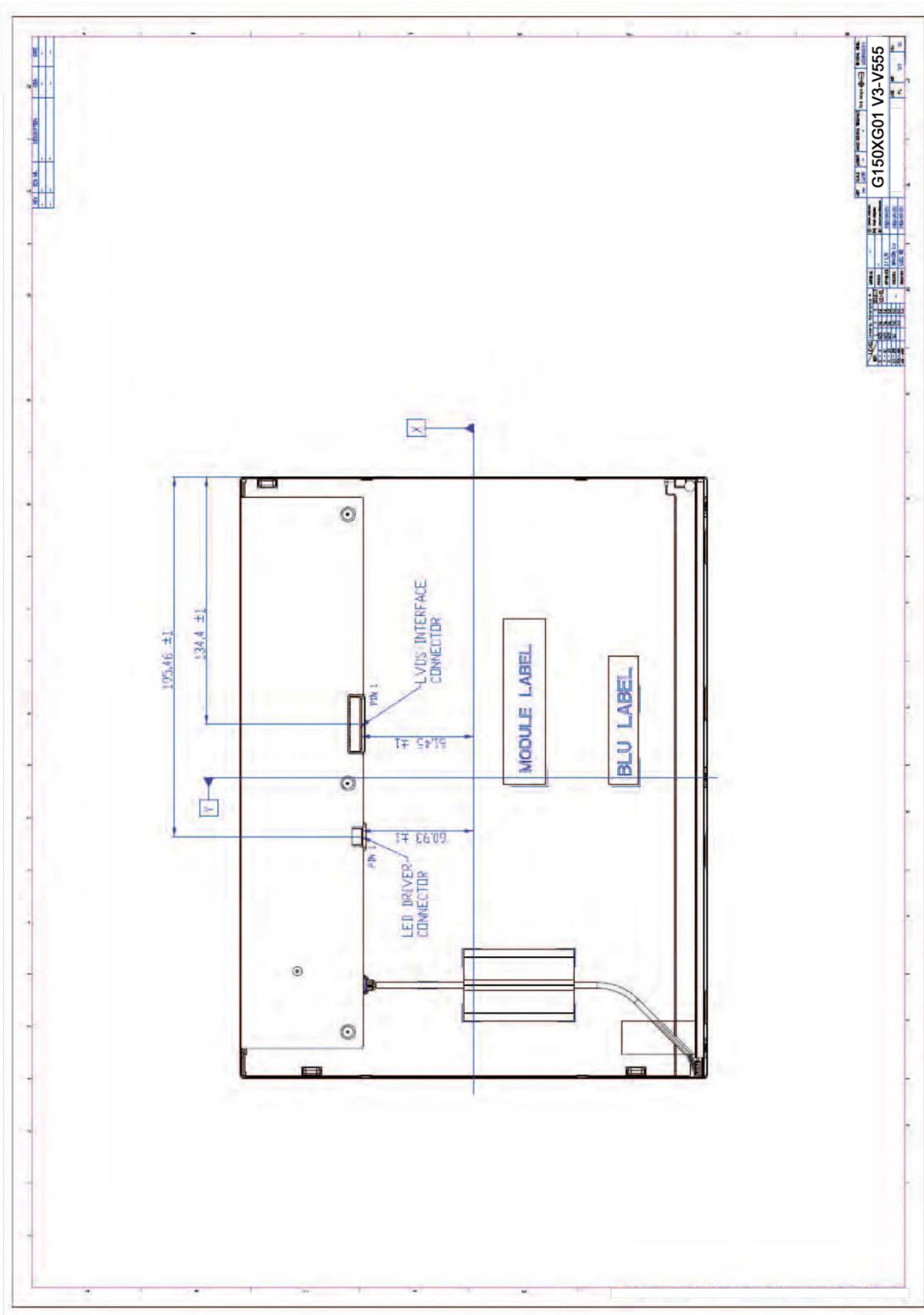

10. Shipping Label

on the rear side of TFT-LCD display



11 Safety

11.1 Sharp Edge Requirements

There will be no sharp edges or comers on the display assembly that could cause injury.

11.2 Materials

11.2.1 Toxicity

There will be no carcinogenic materials used anywhere in the display module. If toxic materials are used, they will be reviewed and approved by the responsible toxicologist.

11.2.2 Flammability

All components including electrical components that do not meet the flammability grade UL94-V1 in the module will complete the flammability rating exception approval process.

The printed circuit board will be made from material rated 94-V1 or better. The actual UL flammability rating will be printed on the printed circuit board.

11.3 Capacitors

If any polarized capacitors are used in the display assembly, provisions will be made to keep them from being inserted backwards.

11.4 National Test Lab Requirement

The display module will satisfy all requirements for compliance to:

UL 1950, First Edition
U.S.A. Information Technology Equipment



DATA DISPLAY GROUP

Our company network supports you worldwide with offices in Germany, Great Britain, Italy, Turkey and the USA. For more information please contact:

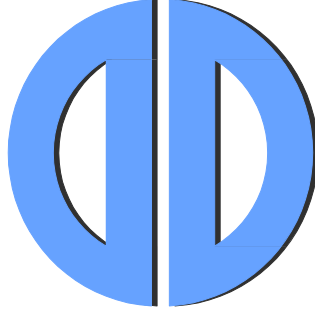

DATA DISPLAY GROUP

Distec GmbH

Augsburger Str. 2b
82110 Germering
Germany

Phone: +49 (0)89 / 89 43 63-0
Fax: +49 (0)89 / 89 43 63-131
E-Mail: info@datadisplay-group.de
Internet: www.datadisplay-group.de

Display Technology Ltd.

5 The Oaks Business Village
Revenge Road, Lordswood
Chatham, Kent, ME5 8LF
United Kingdom

Phone: +44 (0)1634 / 67 27 55
Fax: +44 (0)1634 / 67 27 54
E-Mail: info@datadisplay-group.co.uk
Internet: www.datadisplay-group.co.uk

Data Display S.r.l.

Via Marco Polo, 9/D
I-35010 Trebaseleghe (PD)
Italy

Phone: +39 049 / 72 40 038
Fax: +39 049 / 72 40 039
E-Mail: info@datadisplay-group.it
Internet: www.datadisplay-group.it

Data Display Teknoloji Elektronik San Ve Diş Tic A.Ş.

Kustepe Leylak Sok.
Nursanlar Is Merkezi
Kat. 6 No: 21
Sisli / Istanbul
Turkey

Phone: +90 (0)212 / 356 04 20
Fax: +90 (0)212 / 356 04 25
E-Mail: info@datadisplay-group.com.tr
Internet: www.datadisplay-group.com.tr

Apollo Display Technologies, Corp.

87 Raynor Avenue, Unit 1
Ronkonkoma, NY 11779
United States of America

Phone: +1 631 / 580-43 60
Fax: +1 631 / 580-43 70
E-Mail: info@datadisplay-group.com
Internet: www.datadisplay-group.com
