



OUR GLOBAL  
COMPETENCE  
CENTRES

 APOLLO DISPLAY  
TECHNOLOGIES



 DISTEC



 DISPLAY  
TECHNOLOGY



# Datasheet

## AUO

**B140HAN01.1**

UP-02-110

The information contained in this document has been carefully researched and is, to the best of our knowledge, accurate. However, we assume no liability for any product failures or damages, immediate or consequential, resulting from the use of the information provided herein. Our products are not intended for use in systems in which failures of product could result in personal injury. All trademarks mentioned herein are property of their respective owners. All specifications are subject to change without notice.

---



# Product Specification

AU OPTRONICS CORPORATION

- ( ) Preliminary Specifications
- ( V ) Final Specifications

<b>Module</b>	<b>14.0" FHD 16:9 Color TFT-LCD with LED Backlight design</b>
<b>Model Name</b>	B140HAN01.1 (H/W:3A)
<b>Note</b> (  )	<b><i>LED Backlight with driving circuit design</i></b>

<b>Customer</b>	<b>Date</b>
<b>Checked &amp; Approved by</b>	<b>Date</b>
<p>Note: This Specification is subject to change without notice.</p>	

<b>Approved by</b>	<b>Date</b>
<u>Grace Ho</u>	<u>06/25/2014</u>
<b>Prepared by</b>	<b>Date</b>
<u>Christine Huang</u>	<u>06/25/2014</u>
<p><b>NBBU Marketing Division AU Optronics corporation</b></p>	



## Contents

1. Handling Precautions .....	4
2. General Description .....	5
2.1 General Specification .....	5
2.2 Optical Characteristics.....	6
3. Functional Block Diagram.....	11
4. Absolute Maximum Ratings .....	12
4.1 Absolute Ratings of TFT LCD Module .....	12
4.2 Absolute Ratings of Environment .....	12
5. Electrical Characteristics.....	13
5.1 TFT LCD Module.....	13
5.2 Backlight Unit .....	16
6. Signal Interface Characteristic .....	17
6.1 Pixel Format Image .....	17
6.2 Integration Interface Requirement .....	18
6.3 Interface Timing .....	21
6.4 Power ON/OFF Sequence.....	22
7. Panel Reliability Test .....	25
7.1 Vibration Test .....	25
7.2 Shock Test .....	25
7.3 Reliability Test .....	25
8. Mechanical Characteristics .....	26
8.1 LCM Outline Dimension .....	26
9. Shipping and Package .....	28
9.1 Shipping Label Format .....	28
9.2 Carton Package.....	29
9.3 Shipping Package of Palletizing Sequence.....	30
10. Appendix: EDID Description .....	31



# Product Specification

AU OPTRONICS CORPORATION

## Record of Revision

Version and Date	Page	Old description	New Description	Remark
0.1 2012/7/30	All	First Edition for Customer		
0.2 2012/9/26	5	Revise Luminance Uniformity		
	6	Update Color / Chromaticity Coordinates & Support Color		
	28	Update Shipping label		
	30	Update EDID		
0.3 2012/11/16	6	Update Color / Chromaticity Coordinates		
	13	IDD Current Max 394		
	30	Update EDID		
0.4 2013/1/17	21	Interface Timing		
1.0 2014/3/27	25	Reliability test	Update HTO/HTS/LTS humidity spec	
1.1 2014/6/25	26	2D Drawing	Update 2D Drawing	



## 1. Handling Precautions

- 1) Since front polarizer is easily damaged, pay attention not to scratch it.
- 2) Be sure to turn off power supply when inserting or disconnecting from input connector.
- 3) Wipe off water drop immediately. Long contact with water may cause discoloration or spots.
- 4) When the panel surface is soiled, wipe it with absorbent cotton or other soft cloth.
- 5) Since the panel is made of glass, it may break or crack if dropped or bumped on hard surface.
- 6) Since CMOS LSI is used in this module, take care of static electricity and insure human earth when handling.
- 7) Do not open nor modify the Module Assembly.
- 8) Do not press the reflector sheet at the back of the module to any directions.
- 9) At the insertion or removal of the Signal Interface Connector, be sure not to rotate nor tilt the Interface Connector of the TFT Module.
- 11) After installation of the TFT Module into an enclosure (Notebook PC Bezel, for example), do not twist nor bend the TFT Module even momentarily. At designing the enclosure, it should be taken into consideration that no bending/twisting forces are applied to the TFT Module from outside. Otherwise the TFT Module may be damaged.
- 12) Small amount of materials having no flammability grade is used in the LCD module. The LCD module should be supplied by power complied with requirements of Limited Power Source (IEC60950 or UL1950), or be applied exemption.
- 13) Disconnecting power supply before handling LCD modules, it can prevent electric shock, DO NOT TOUCH the electrode parts, cables, connectors and LED circuit part of TFT module that a LED light bar build in as a light source of back light unit. It can prevent electrostatic breakdown.



# Product Specification

AU OPTRONICS CORPORATION

## 2. General Description

B140HAN01.1 is a Color Active Matrix Liquid Crystal Display composed of a TFT LCD panel, a driver circuit, and LED backlight system. The screen format is intended to support the 16:9 FHD, 1920(H)x1080(V) screen and 262k colors (RGB 6-bits data driver) with LED backlight driving circuit. All input signals are eDP(Embedded DisplayPort) interface compatible.

B140HAN01.1 is designed for a display unit of notebook style personal computer and industrial machine.

### 2.1 General Specification

The following items are characteristics summary on the table at 25 condition:

Items	Unit	Specifications			
Screen Diagonal	[mm]	354.69			
Active Area	[mm]	309.14 X 173.89			
Pixels H x V		1920x3(RGB) x 1080			
Pixel Pitch	[mm]	0.161X0.161			
Pixel Format		R.G.B. Vertical Stripe			
Display Mode		Normally Black			
White Luminance (ILED=22mA) (Note: ILED is LED current)	[cd/m <sup>2</sup> ]	300 typ. (5 points average) 255 min. (5 points average)			
Luminance Uniformity		1.25 max. (5 points)			
Contrast Ratio		700 typ			
Response Time	[ms]	25			
Nominal Input Voltage VDD	[Volt]	+3.3 typ.			
Power Consumption	[Watt]	5.4W @ mosaic pattern			
Weight	[Grams]	300 max.			
Physical Size Include bracket	[mm]		Min.	Typ.	Max.
		Length	319.9	320.4	320.9
		Width	204.6	205.1	205.6
		Thickness	-	-	3.2
Electrical Interface		2 Lane eDP1.3			
Glass Thickness	[mm]	0.5			
Surface Treatment		Anti - Glare, Hardness 3H			
Support Color		6-bit + FRC			
Temperature Range	[°C]	Operating			
		Storage (Non-Operating)			
	[°C]	0 to +50 -20 to +60			
RoHS Compliance		RoHS Compliance			



## 2.2 Optical Characteristics

The optical characteristics are measured under stable conditions at 25 (Room Temperature) :

Item	Symbol	Conditions	Min.	Typ.	Max.	Unit	Note		
White Luminance $I_{LED}=22mA$		5 points average	255	300	-	cd/m <sup>2</sup>	1, 4, 5.		
Viewing Angle	R	Horizontal (Right) CR = 10 (Left)	85	89	-	degree	4, 9		
	L		85	89	-				
	H	Vertical (Upper) CR = 10 (Lower)	85	89	-	degree			
	L		85	89	-				
Luminance Uniformity	5P	5 Points	-	-	1.25		1, 3, 4		
Luminance Uniformity	13P	13 Points	-	-	1.6		2, 3, 4		
Contrast Ratio	CR		-	700	-		4, 6		
Cross talk	%				4		4, 7		
Response Time	T <sub>RT</sub>	Rising + Falling	-	25	35	msec	4, 8		
Color / Chromaticity Coordinates	Red	Rx	CIE 1931	0.614	0.644	0.674	4		
		Ry		0.305	0.335	0.365			
	Green	Gx		0.284	0.314	0.344			
		Gy		0.598	0.628	0.658			
	Blue	Bx		0.126	0.156	0.186			
		By		0.029	0.059	0.089			
	White	Wx		0.283	0.313	0.343			
		Wy		0.299	0.329	0.359			
	NTSC	%			-	72		-	



**Note 1:** 5 points position (Ref: Active area)

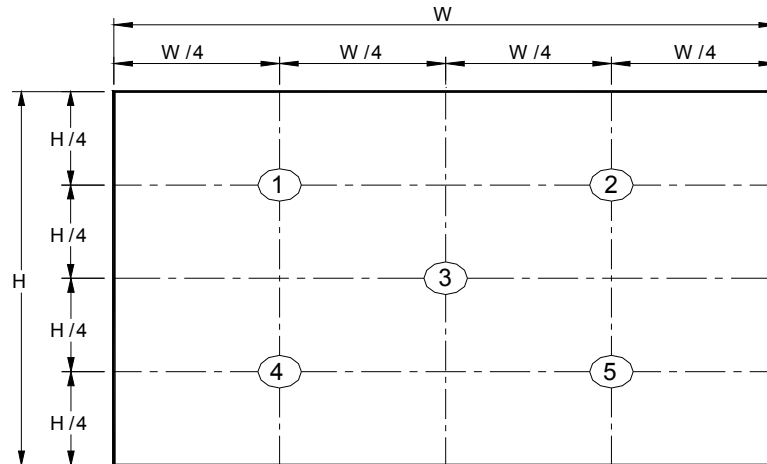

**Note 2:** 13 points position (Ref: Active area)

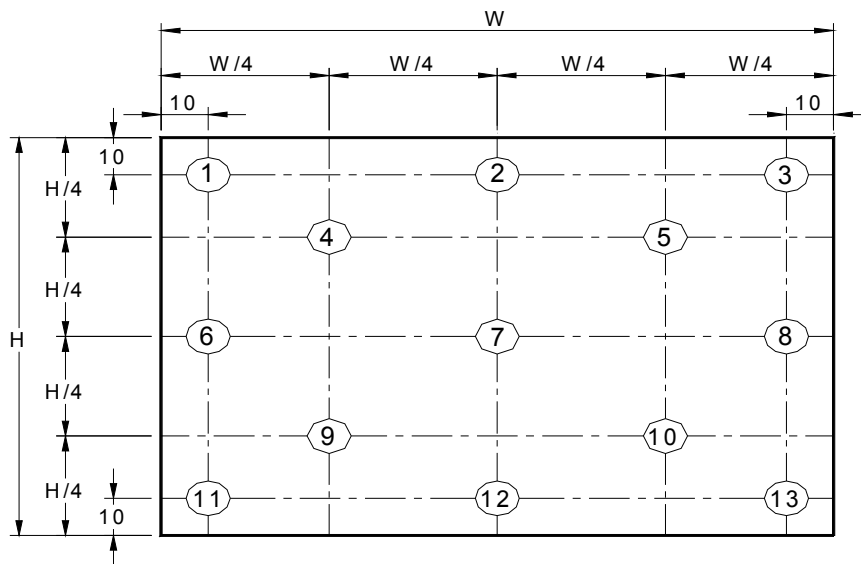

**Note 3:** The luminance uniformity of 5 or 13 points is defined by dividing the maximum luminance values by the minimum test point luminance

$$w_5 = \frac{\text{Maximum Brightness of five points}}{\text{Minimum Brightness of five points}}$$

$$w_{13} = \frac{\text{Maximum Brightness of thirteen points}}{\text{Minimum Brightness of thirteen points}}$$

**Note 4:** Measurement method

The LCD module should be stabilized at given temperature for 30 minutes to avoid abrupt temperature change during measuring. In order to stabilize the luminance, the measurement should be executed after lighting

Backlight for 30 minutes in a stable, windless and dark room, and it should be measured in the center of screen.

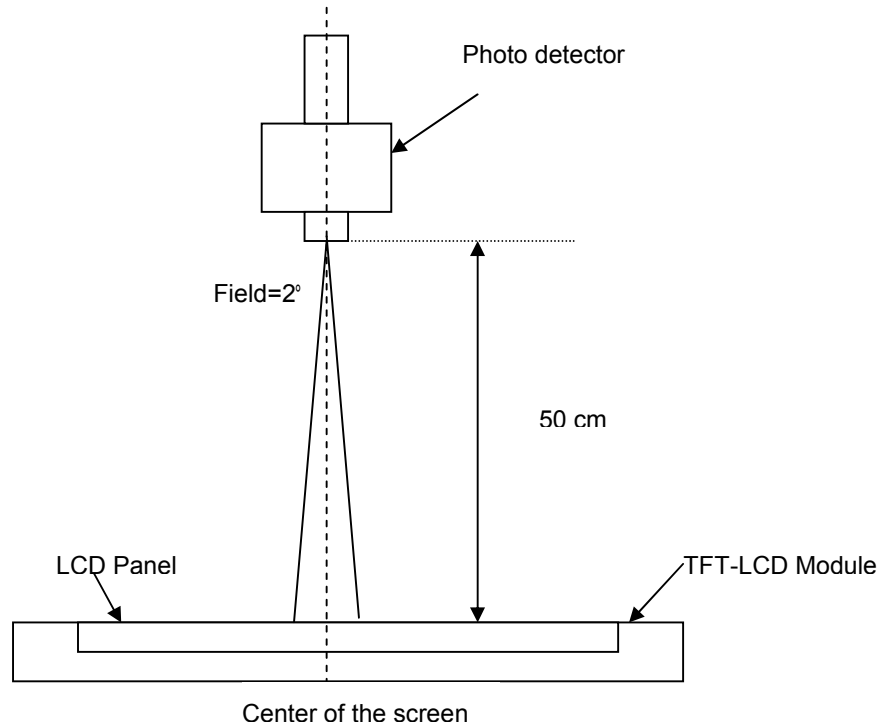

**Note 5 :** Definition of Average Luminance of White ( $Y_L$ ):

Measure the luminance of gray level 63 at 5 points ,  $Y_L = [L (1)+ L (2)+ L (3)+ L (4)+ L (5)] / 5$

$L (x)$  is corresponding to the luminance of the point X at Figure in Note (1).

**Note 6 :** Definition of contrast ratio:

Contrast ratio is calculated with the following formula.

$$\text{Contrast ratio (CR)} = \frac{\text{Brightness on the "White" state}}{\text{Brightness on the "Black" state}}$$

**Note 7 :** Definition of Cross Talk (CT)

$$CT = |Y_B - Y_A| / Y_A \times 100 (\%)$$

Where

$Y_A$  = Luminance of measured location without gray level 0 pattern (cd/m<sup>2</sup>)

$Y_B$  = Luminance of measured location with gray level 0 pattern (cd/m<sup>2</sup>)

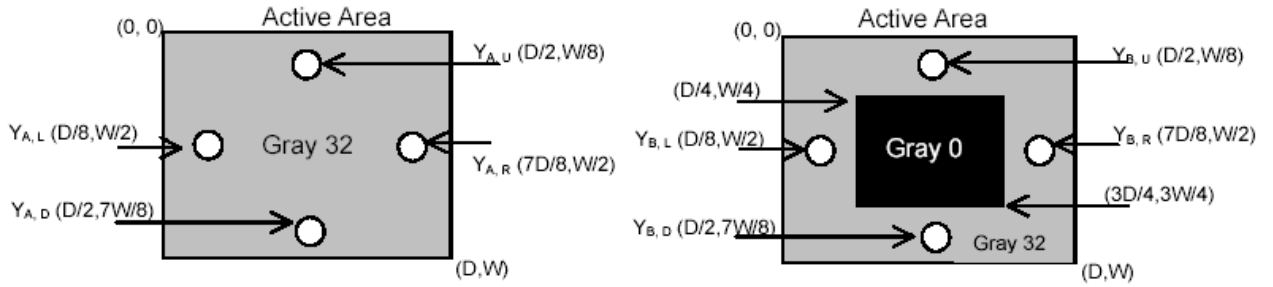

**Note 8:** Definition of response time:

The output signals of BM-7 or equivalent are measured when the input signals are changed from "Black" to "White" (falling time) and from "White" to "Black" (rising time), respectively. The response time interval between the 10% and 90% of amplitudes. Refer to figure as below.

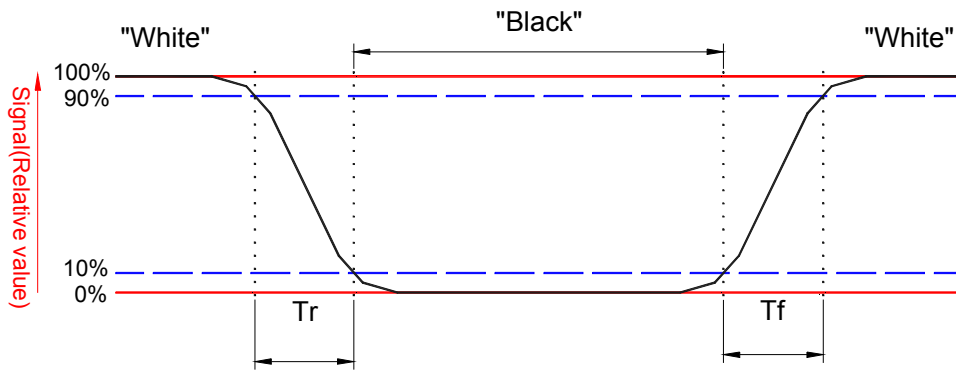

**Note 9.** Definition of viewing angle

Viewing angle is the measurement of contrast ratio  $\geq 10$ , at the screen center, over a  $180^\circ$  horizontal and  $180^\circ$  vertical range (off-normal viewing angles). The  $180^\circ$  viewing angle range is broken down as follows;  $90^\circ$  ( $\theta$ ) horizontal left and right and  $90^\circ$  ( $\Phi$ ) vertical, high (up) and low (down). The measurement direction is typically perpendicular to the display surface with the screen rotated about its center to develop the desired measurement viewing angle.

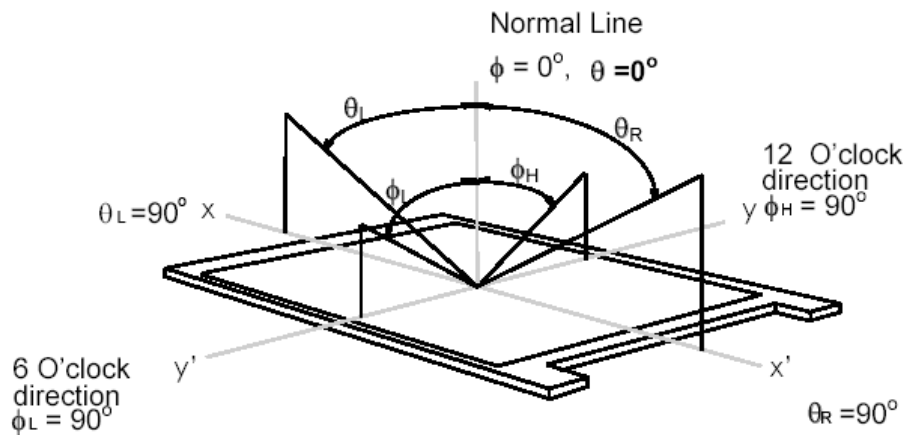

## 3. Functional Block Diagram

The following diagram shows the functional block of the 14.0 inches wide Color TFT/LCD 30 Pin

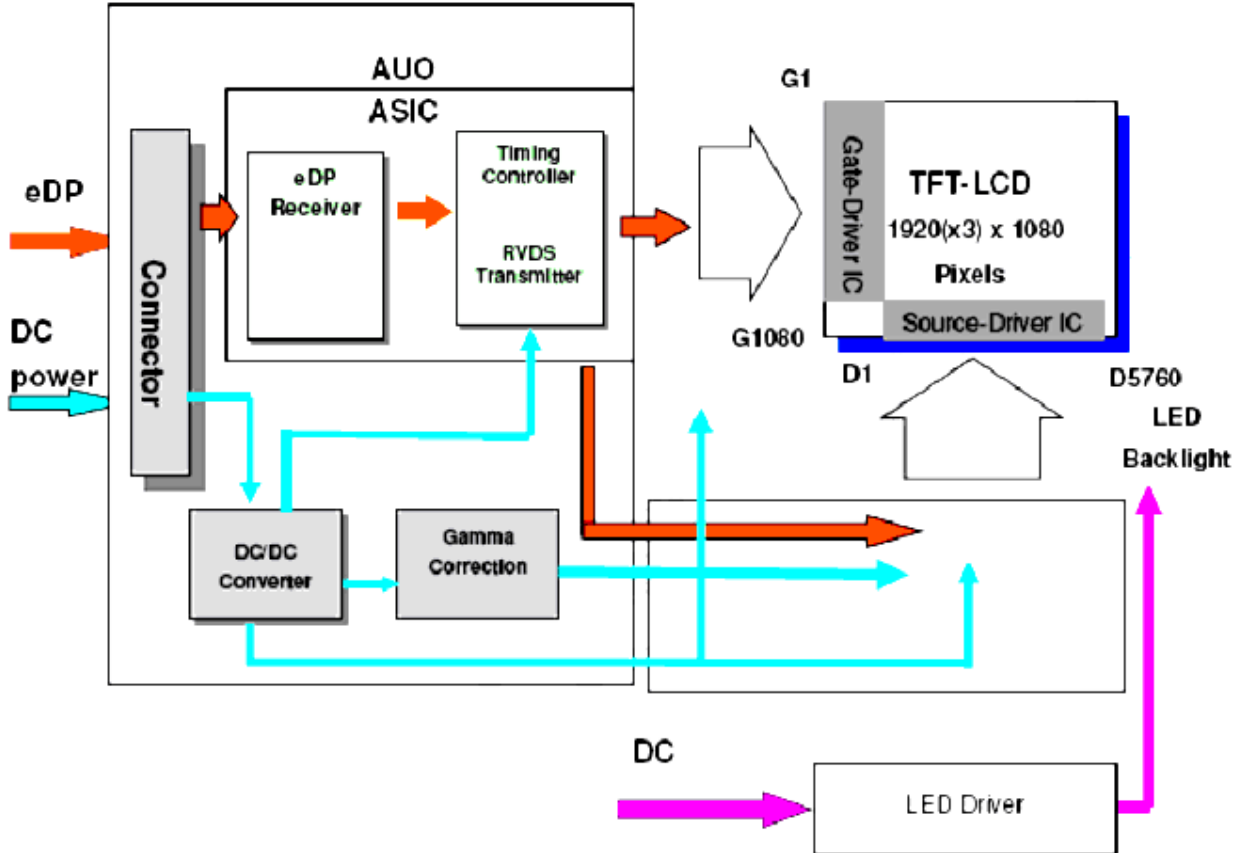

## 4. Absolute Maximum Ratings

An absolute maximum rating of the module is as following:

### 4.1 Absolute Ratings of TFT LCD Module

Item	Symbol	Min	Max	Unit	Conditions
Logic/LCD Drive Voltage	Vin	-0.3	+4.0	[Volt]	Note 1,2

### 4.2 Absolute Ratings of Environment

Item	Symbol	Min	Max	Unit	Conditions
Operating Temperature	TOP	0	+50	[°C]	Note 4
Operation Humidity	HOP	5	95	[%RH]	Note 4
Storage Temperature	TST	-20	+60	[°C]	Note 4
Storage Humidity	HST	5	95	[%RH]	Note 4

Note 1: At Ta (25 )

Note 2: Permanent damage to the device may occur if exceed maximum values

Note 3: LED specification refer to section 5.2

Note 4: For quality performance, please refer to AUO IIS (Incoming Inspection Standard).

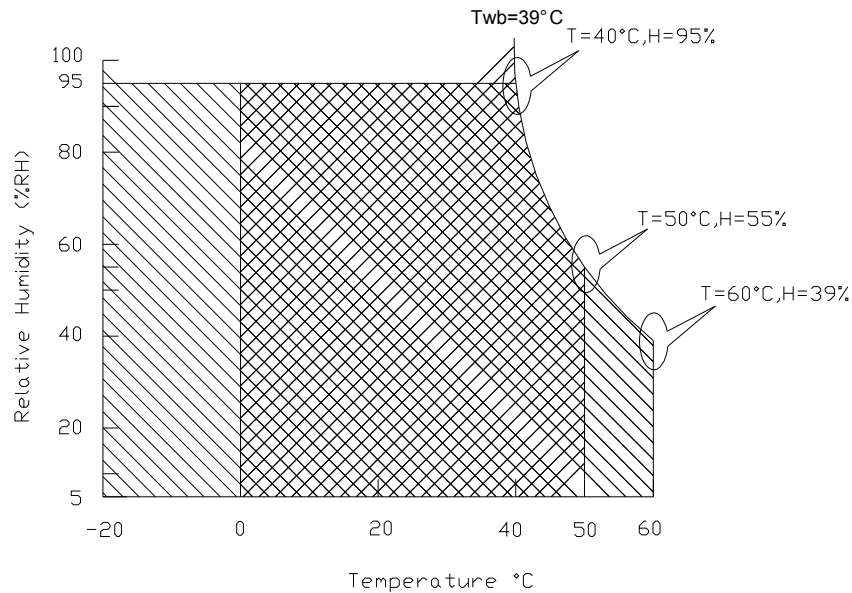

Operating Range

Storage Range +

## 5. Electrical Characteristics

### 5.1 TFT LCD Module

#### 5.1.1 Power Specification

Input power specifications are as follows;

The power specification are measured under 25 °C and frame frequency under 60Hz

Symbol	Parameter	Min	Typ	Max	Units	Note
VDD	Logic/LCD Drive Voltage	3.0	3.3	3.6	[Volt]	
PDD	VDD Power	-	-	1.4	[Watt]	Note 1
IDD	IDD Current	-	-	433	[mA]	Note 1
IRush	Inrush Current	-	-	1500	[mA]	Note 2
VDDrp	Allowable Logic/LCD Drive Ripple Voltage	-	-	100	[mV] p-p	

Note 1 : Maximum Measurement Condition : Black Pattern at 3.3V driving voltage. ( $P_{max} = V_{3.3} \times I_{black}$ )

Typical Measurement Condition: Mosaic Pattern

Note 2 : Measure Condition

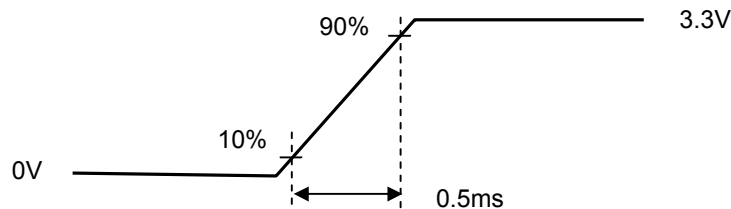
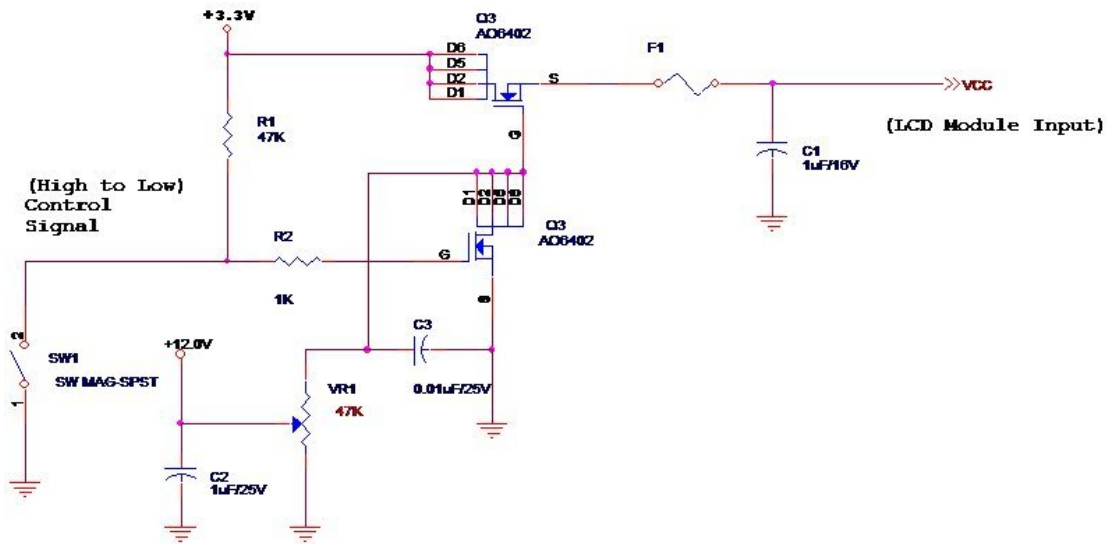

## 5.1.2 Signal Electrical Characteristics

Input signals shall be low or High-impedance state when VDD is off.

Signal electrical characteristics are as follows;

### Display Port main link signal:

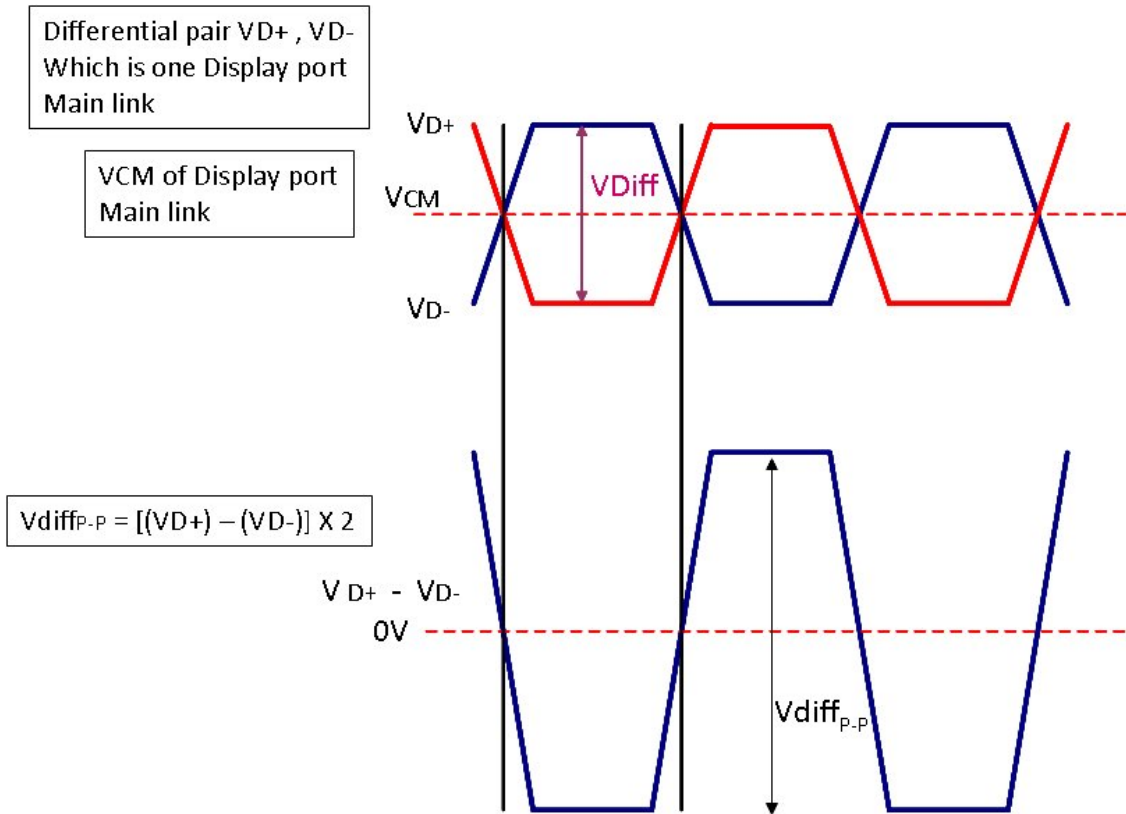



## Display Port AUX\_CH signal:

Differential AUX+ , AUX-  
Which is Display port AUX\_CH

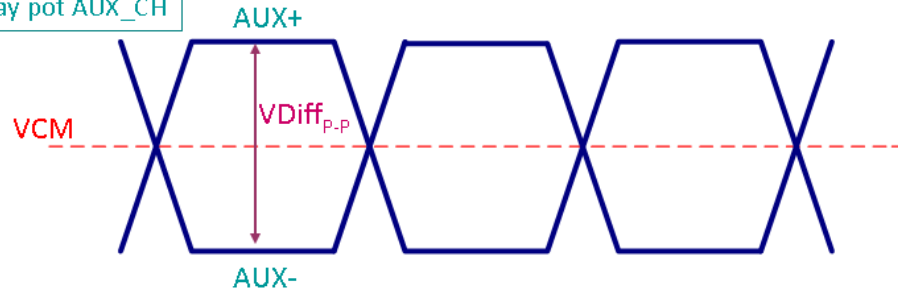

Display port AUX_CH					
		Min	Typ	Max	unit
VCM	AUX DC Common Mode Voltage		0		V
VDiff <sub>p.p</sub>	AUX Peak-to-peak Voltage at a receiving Device	0.4	0.6	0.8	V

Fallow as VESA display port standard V1.3

## Display Port VHPD signal:

Display port VHPD					
		Min	Typ	Max	unit
VHPD	HPD Voltage	2		2.5	V

Fallow as VESA display port standard V1.3



## 5.2 Backlight Unit

### 5.2.1 LED characteristics

Parameter	Symbol	Min	Typ	Max	Units	Condition
Backlight Power Consumption	PLED	-	-	4	[Watt]	(Ta=25 °C), Note 1 Vin =12V
LED Life-Time	N/A	15,000	-	-	Hour	(Ta=25 °C), Note 2 If=22 mA

Note 1: Calculator value for reference  $P_{LED} = VF$  (Normal Distribution) \*  $I_F$  (Normal Distribution) / Efficiency

Note 2: The LED life-time define as the estimated time to 50% degradation of initial luminous.

Note 3: LED input Current 0.333A typ / LED Forward Current 22mA per string, total 88mA / LED Forward Voltage 24V typ / LED Array 4parallel \* 8series

### 5.2.2 Backlight input signal characteristics

Parameter	Symbol	Min	Typ	Max	Units	Remark
LED Power Supply	VLED	5.0 Note2	12.0	21.0	[Volt]	Define as Connector Interface (Ta=25 °C)
LED Enable Input High Level	VLED_EN	2.5	-	3.3	[Volt]	
LED Enable Input Low Level		-	-	0.5	[Volt]	
PWM Logic Input High Level	VPWM_EN	2.5	-	3.3	[Volt]	
PWM Logic Input Low Level		-	-	0.5	[Volt]	
PWM Input Frequency	FPWM	200	1K	10K	Hz	
PWM Duty Ratio	Duty	5	--	100	%	

**Note 1** : Recommend system pull up/down resistor no bigger than 10kohm

**Note 2** : measured in panel VLED at PWM duty ratio 100%

## 6. Signal Interface Characteristic

### 6.1 Pixel Format Image

Following figure shows the relationship of the input signals and LCD pixel format.

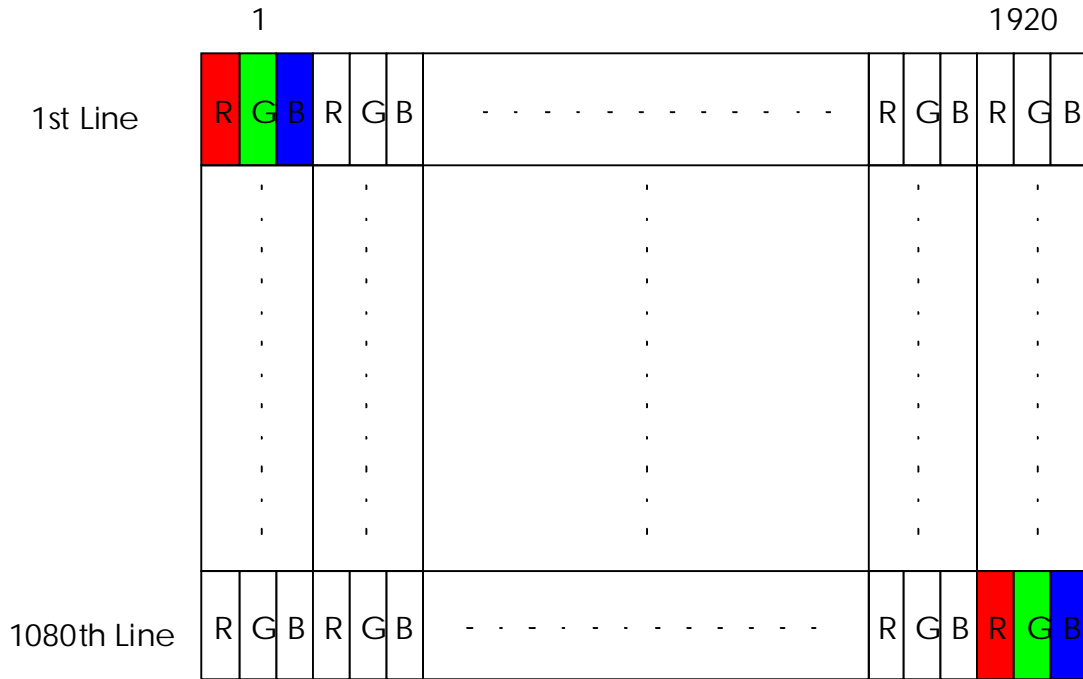



## 6.2 Integration Interface Requirement

### 6.2.1 Connector Description

Physical interface is described as for the connector on module.

These connectors are capable of accommodating the following signals and will be following components.

<b>Connector Name / Designation</b>	<b>For Signal Connector</b>
Manufacturer	IPEX or compatible
Type / Part Number	IPEX 20455-030E-12 or compatible
Mating Housing/Part Number	IPEX 20453-030T-11 or compatible

## 6.2.2 Pin Assignment (2 Lane)

eDP lane is a differential signal technology for LCD interface and high speed data transfer device.

PIN NO	Symbol	Function
1	DBC_EN	NC
2	H_GND	High Speed Ground
3	Lane1_N	Complement Signal Link Lane 1
4	Lane1_P	True Signal Link Lane 1
5	H_GND	High Speed Ground
6	Lane0_N	Complement Signal Link Lane 0
7	Lane0_P	True Signal Link Lane 0
8	H_GND	High Speed Ground
9	AUX_CH_P	True Signal Auxiliary Ch.
10	AUX_CH_N	Complement Signal Auxiliary Ch.
11	H_GND	High Speed Ground
12	LCD_VCC	LCD logic and driver power
13	LCD_VCC	LCD logic and driver power
14	LCD_Self_Test	LCD Panel Self Test Enable
15	LCD_GND	LCD logic and driver ground
16	LCD_GND	LCD logic and driver ground
17	HPD	Hot Plug Detection signal pin
18	BL_GND	Backlight_ground
19	BL_GND	Backlight_ground
20	BL_GND	Backlight_ground
21	BL_GND	Backlight_ground
22	BL_Enable	Backlight On / Off
23	BL_PWM_DIM	System PWM signal Input
24	NC	Reverse for AUO TEST only
25	NC	Reverse for AUO TEST only
26	BL_PWR	Backlight power (5V~21V)
27	BL_PWR	Backlight power (5V~21V)
28	BL_PWR	Backlight power (5V~21V)
29	BL_PWR	Backlight power (5V~21V)
30	COLOR_EN	NC

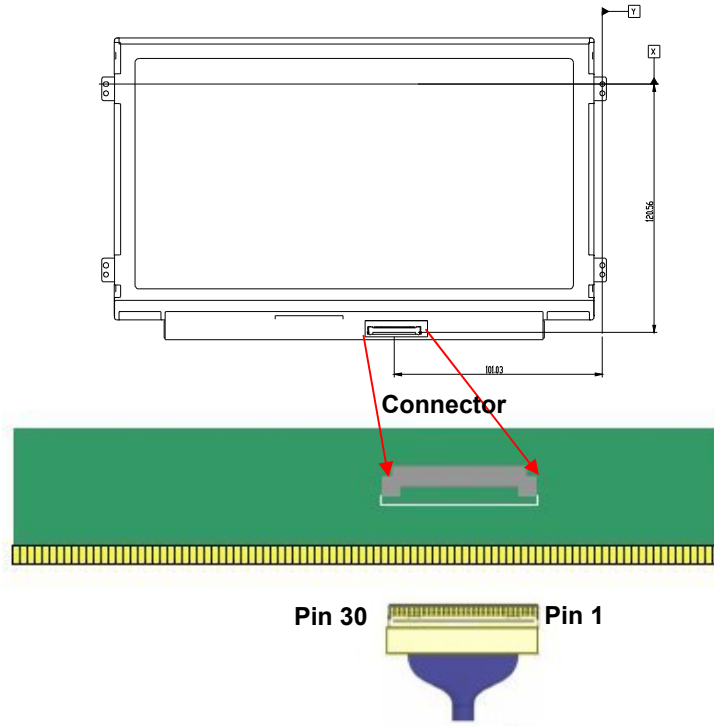

Note1: Start from right side.

Note2: Input signals shall be low or High-impedance state when VDD is off.  
Internal circuit of eDP inputs are as following.

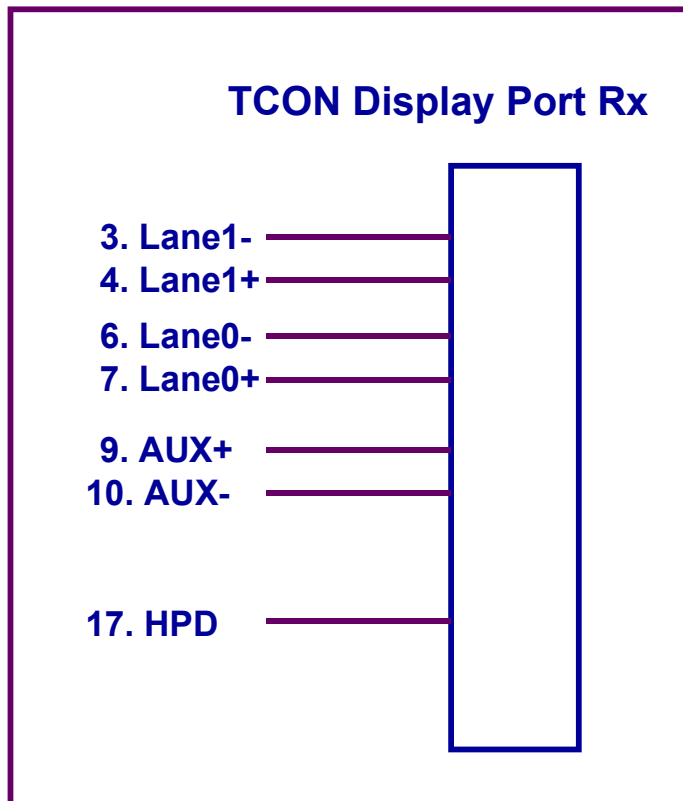

## 6.3 Interface Timing

### 6.3.1 Timing Characteristics

Basically, interface timings should match the 1920x1080 /60Hz manufacturing guide line timing.

Parameter		Symbol	Min.	Typ.	Max.	Unit
Frame Rate		-	-	60	-	Hz
Clock frequency		1/ T <sub>clock</sub>		141		MHz
Vertical Section	Period	T <sub>V</sub>	1090	1116	3080	T <sub>Line</sub>
	Active	T <sub>VD</sub>	1080			
	Blanking	T <sub>VB</sub>	10	36	2000	
Horizontal Section	Period	T <sub>H</sub>	2000	2104	2320	T <sub>clock</sub>
	Active	T <sub>HD</sub>	1920			
	Blanking	T <sub>HB</sub>	80	184	400	

## 6.4 Power ON/OFF Sequence

Display Port panel power sequence:

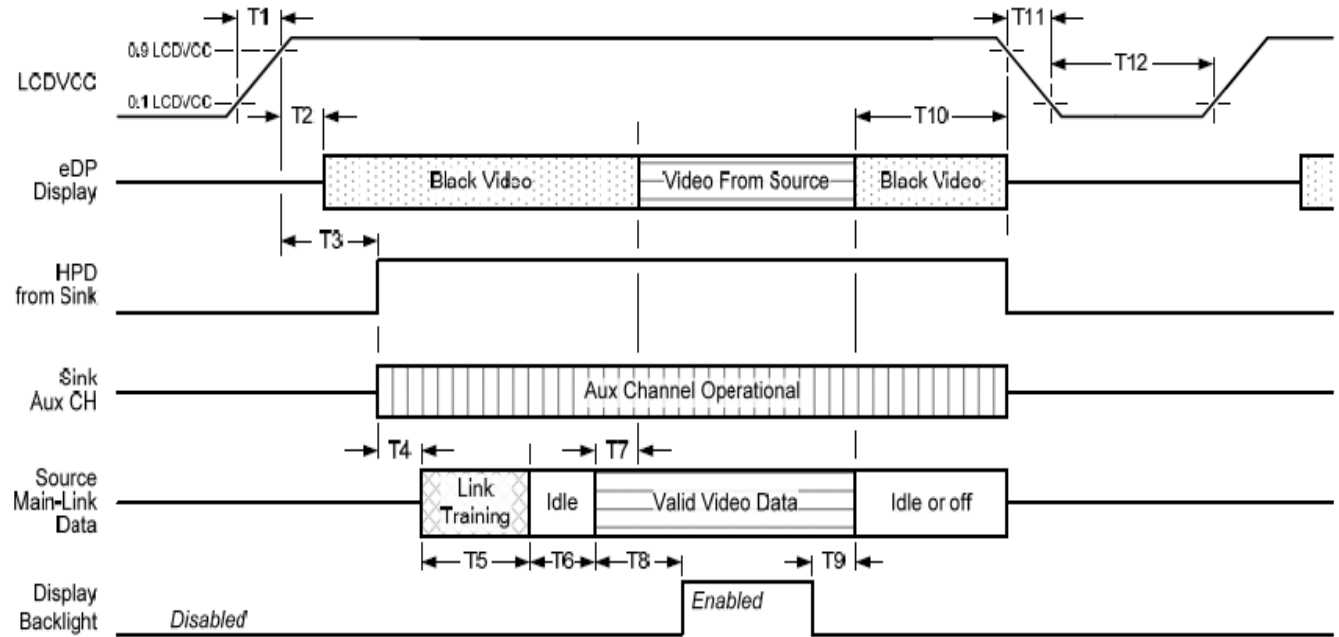

Display port interface power up/down sequence, normal system operation

Display Port AUX\_CH transaction only:

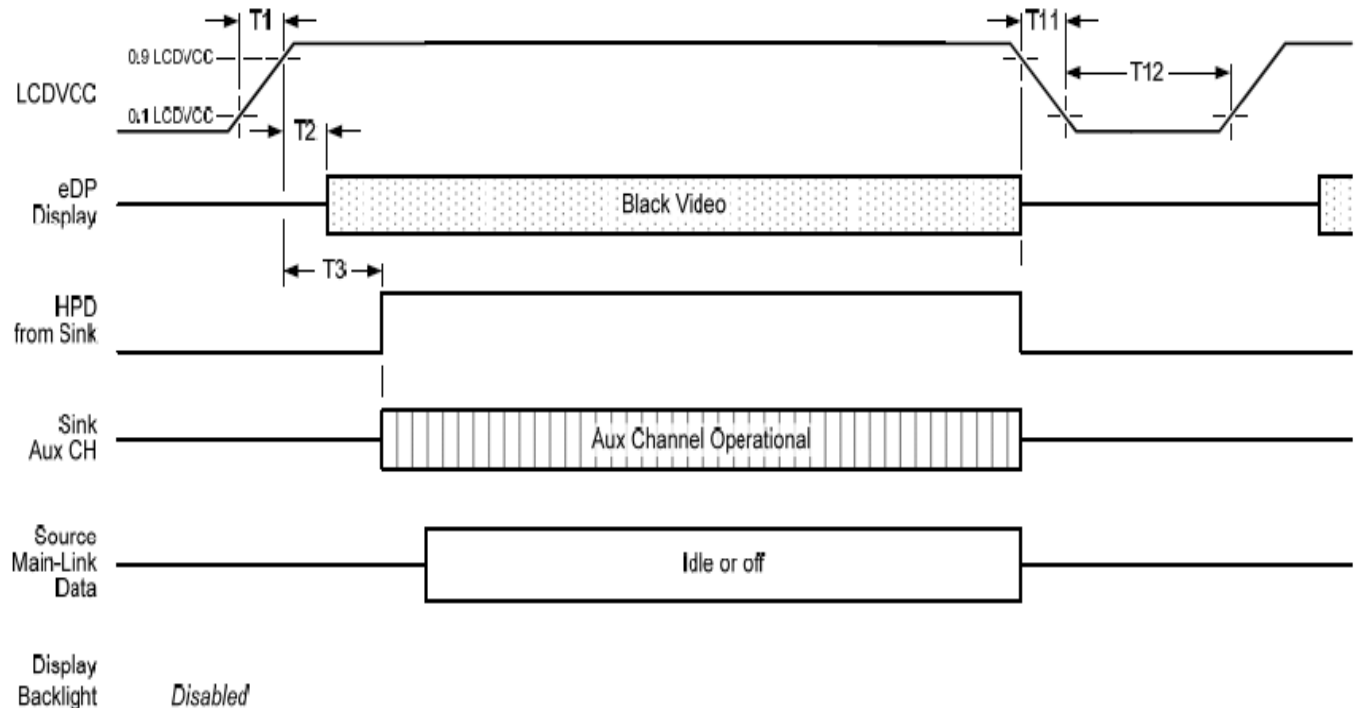

Display port interface power up/down sequence, AUX\_CH transaction only





## Display Port panel power sequence timing parameter:

Timing parameter	Description	Reqd. by	Limits			Notes
			Min.	Typ.	Max.	
T1	power rail rise time, 10% to 90%	source	0.5ms		10ms	
T2	delay from LCDVDD to black video generation	sink	0ms		200ms	prevents display noise until valid video data is received from the source
T3	delay from LCDVDD to HPD high	sink	0ms		200ms	sink AUX_CH must be operational upon HPD high.
T4	delay from HPD high to link training initialization	source				allows for source to read link capability and initialize.
T5	link training duration	source				dependant on source link to read training protocol.
T6	link idle	source				Min accounts for required BS-Idle pattern. Max allows for source frame synchronization.
T7	delay from valid video data from source to video on display	sink	0ms		50ms	max allows sink validate video data and timing.
T8	delay from valid video data from source to backlight enable	source				source must assure display video is stable.
T9	delay from backlight disable to end of valid video data	source				source must assure backlight is no longer illuminated.
T10	delay from end of valid video data from source to power off	source	0ms		500ms	
T11	power rail fall time, 90% to 10%	source			10ms	
T12	power off time	source	500ms			

Note1: The sink must include the ability to generate black video autonomously. The sink must automatically enable black video under the following conditions:

- upon LCDVDD power on (with in T2 max)-when the "Novideostream\_Flag" (VB-ID Bit 3) is received from the source (at the end of T9).

- when no main link data, or invalid video data, is received from the source. Black video must be displayed within 64ms (typ) from the start of either condition. Video data can be deemed invalid based on MSA and timing information, for example.

Note 2: The sink may implement the ability to disable the black video function, as described in Note 1, above, for system development and debugging purpose.

Note 3: The sink must support AUX\_CH polling by the source immediately following LCDVDD power on without causing damage to the sink device (the source can re-try if the sink is not ready). The sink must be able to respond to an AUX\_CH transaction with the time specified within T3 max.

## Display Port panel B/L power sequence timing parameter:

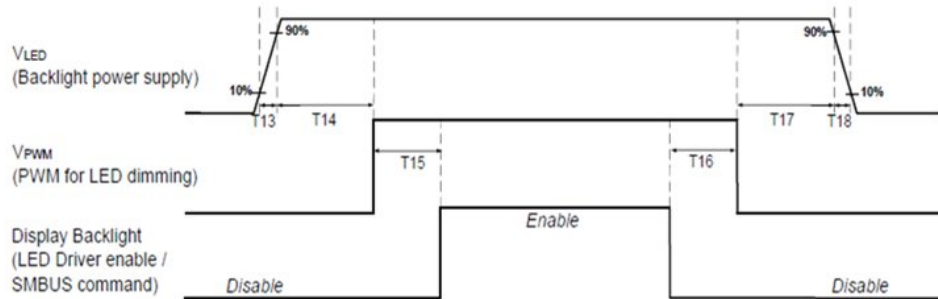

Note : When the adapter is hot plugged, the backlight power supply sequence is shown as below.

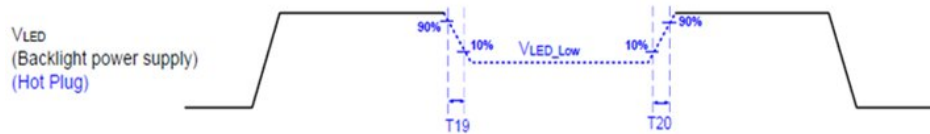

	Min (ms)	Max (ms)
T13	0.5	10
T14	10	-
T15	10	-
T16	10	-
T17	10	-
T18	0.5	10
T19	1*	-
T20	1*	-

Seamless change:  $T19/T20 = 5 \times T_{PWM}^*$

\* $T_{PWM} = 1/PWM \text{ Frequency}$

## 7. Panel Reliability Test

### 7.1 Vibration Test

**Test Spec:**

- Test method: Non-Operation
- Acceleration: 1.5 G
- Frequency: 10 - 500Hz Random
- Sweep: 30 Minutes each Axis (X, Y, Z)

### 7.2 Shock Test

**Test Spec:**

- Test method: Non-Operation
- Acceleration: 220 G , Half sine wave
- Active time: 2 ms
- Pulse: X,Y,Z .one time for each side

### 7.3 Reliability Test

Items	Required Condition	Note
Temperature Humidity Bias	Ta= 40 , 90%RH, 300h	
High Temperature Operation	Ta= 50 , 300h	
Low Temperature Operation	Ta= 0 , 300h	
High Temperature Storage	Ta= 60 , 300h	
Low Temperature Storage	Ta= -20 , 300h	
Thermal Shock Test	Ta=-20 to 60 , Duration at 30 min, 100 cycles	
ESD	Contact : ±8 KV Air : ±15 KV	Note 2

**Note 1:** In the standard conditions, there is not display function NG issue occurred. All the cosmetic specification is judged before the reliability stress.

**Note2 :** According to EN 61000-4-2 , ESD class B: Some performance degradation allowed. Self-recoverable.

No data lost, No hardware failures.

**Remark:** MTBF (Excluding the LED): 30,000 hours with a confidence level 90%



# Product Specification

AU OPTRONICS CORPORATION

## 8. Mechanical Characteristics

### 8.1 LCM Outline Dimension

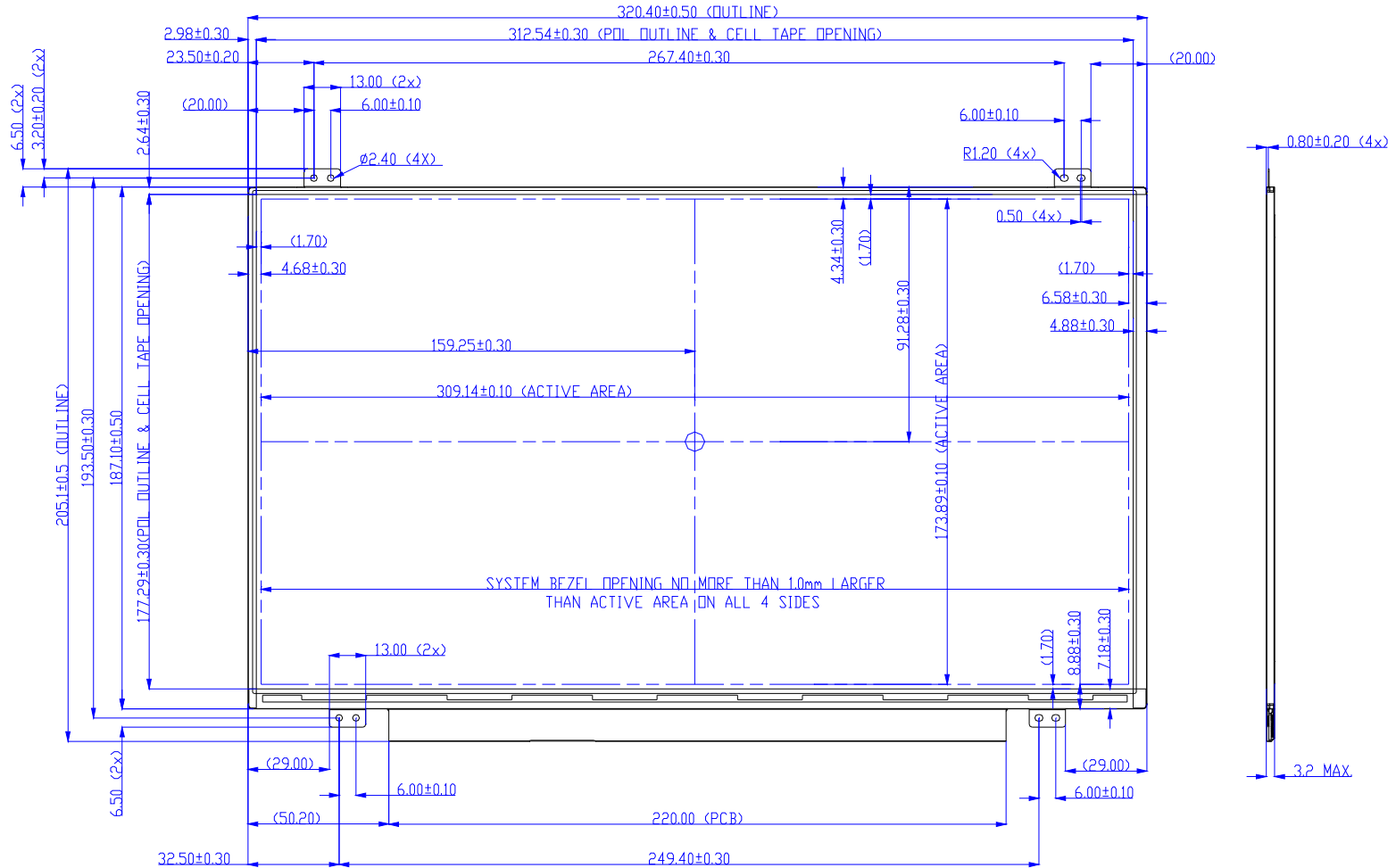

# Product Specification

AU OPTRONICS CORPORATION

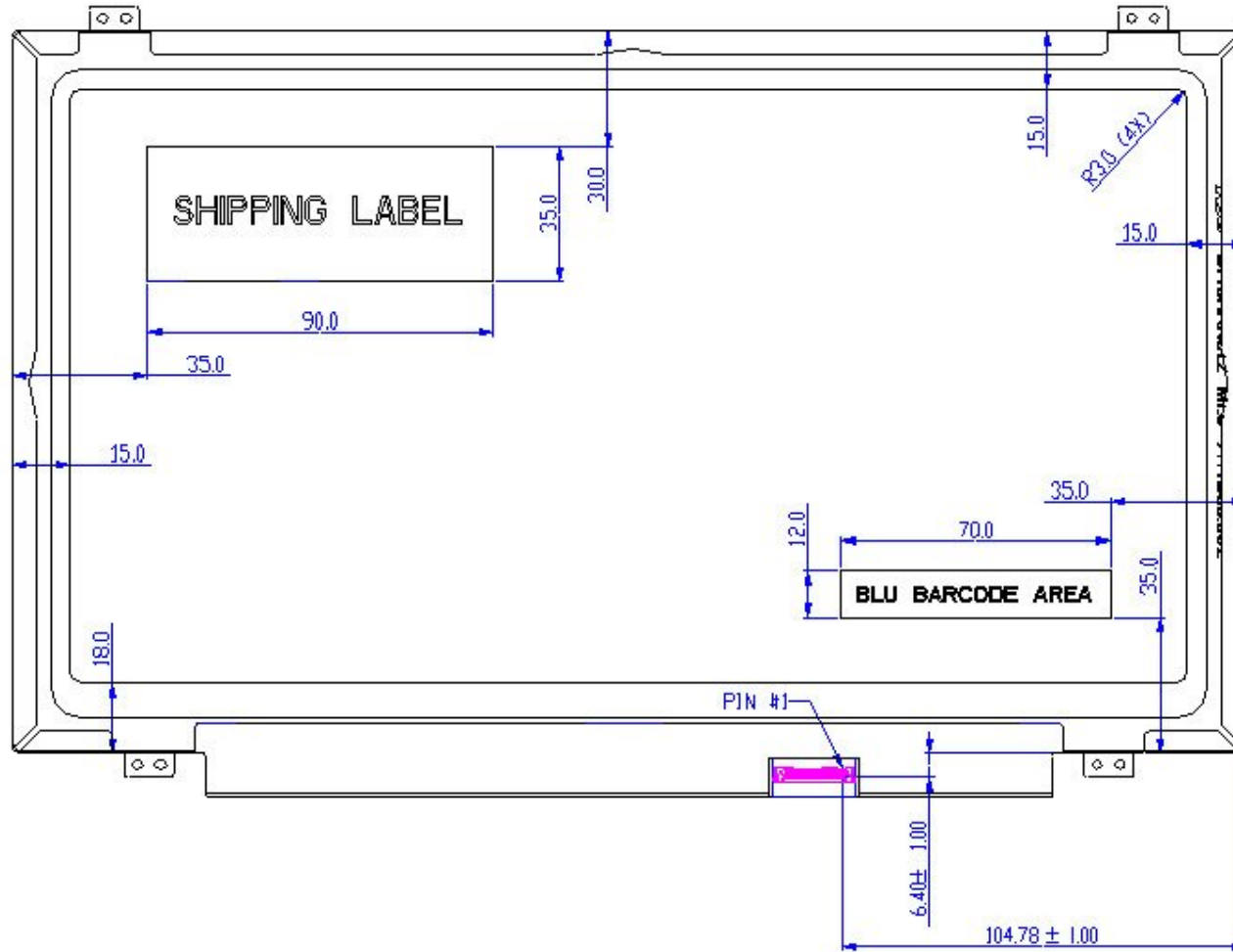

Note: Prevention IC damage, IC positions not allowed any overlap over these areas.

## 9. Shipping and Package

### 9.1 Shipping Label Format

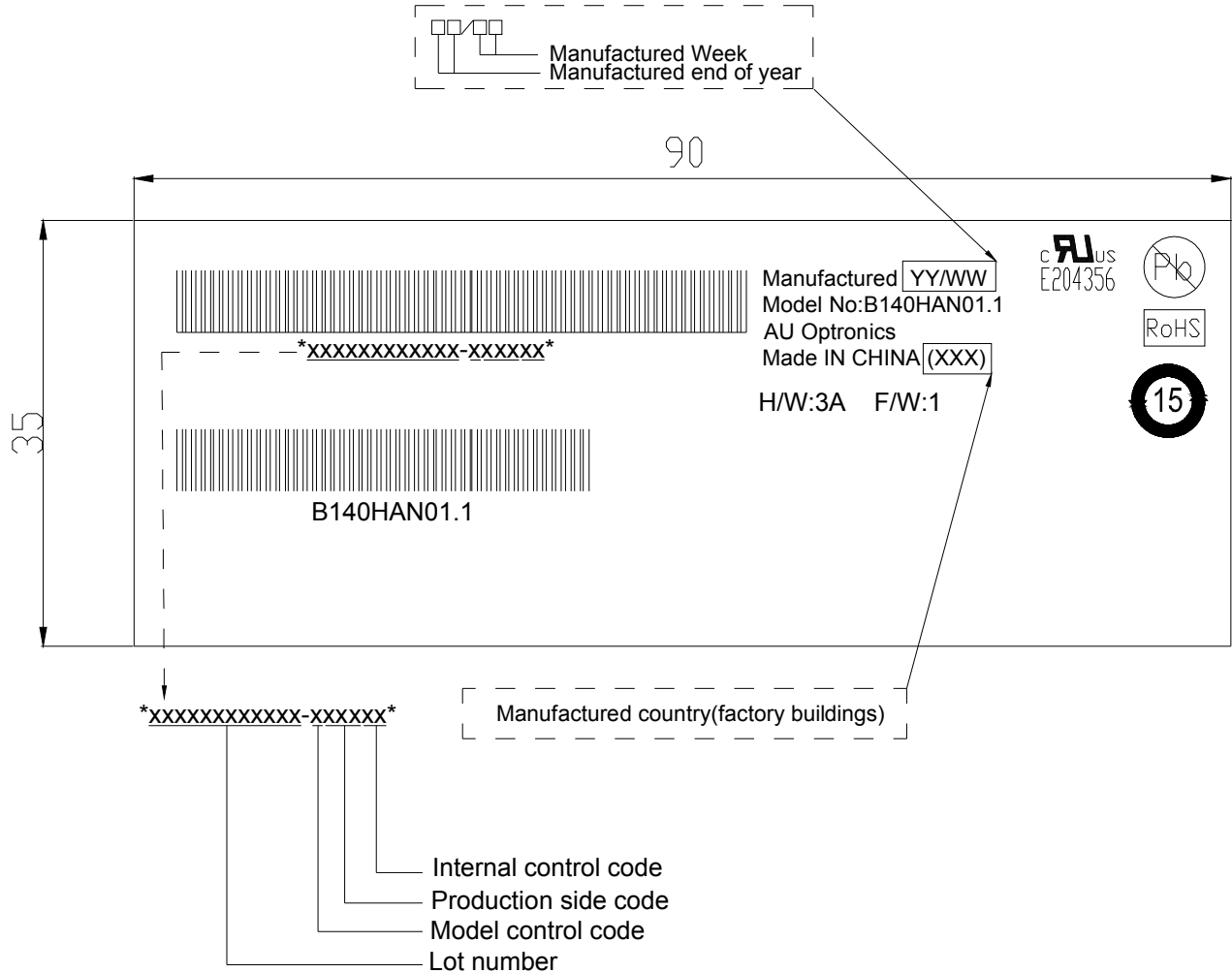

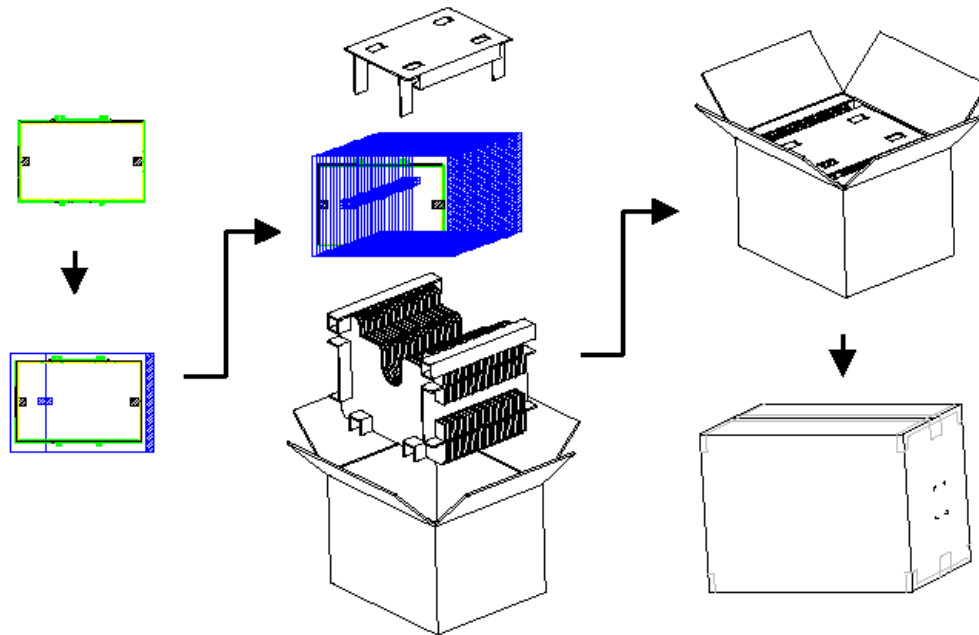

Max capacity : 40 TFT-LCD module per carton

Max weight: 17.0 kg per carton

Outside dimension of carton: 406mm(L)\* 376mm(W)\*308mm(H)

Pallet size : 1140 mm \* 830 mm \* 135mm

## 9.3 Shipping Package of Palletizing Sequence

Module by air : (2 \*3) \*4 layers , one pallet put 24 boxes , total 960pcs module

Module by sea : (2 \*3) \*4 layers + (2 \*3) \*2 layers , two pallet put 36 boxes , total 1440pcs module

Module by sea\_HQ : (2 \*3) \*4 layers+(2 \*3) \*3 layers, two pallet put 42 boxes, total 1680pcs module

	MAX SHIPPING BY AIR	MAX SHIPPING BY SEA	MAX SHIPPING BY SEA_HQ
MODULE/CARTON	40	40	40
CARTON/LAYER	6	6	6
LAYER/PALLET	4	4+2	4+3
MODULE/PALLET	960	1440	1680
CARTON SIZE(MM)	406(L)*376(W)*308(H)	406(L)*376(W)*308(H)	406(L)*376(W)*308(H)
PALLET SIZE(MM)	1150(L)*840(W)*135(H)	1150(L)*840(W)*135(H)	1150(L)*840(W)*135(H)
TOTAL PALLET HEIGHT(MM)	1367	2118	2426
TOTAL PALLET WEIGHT(KG)	421	638	740

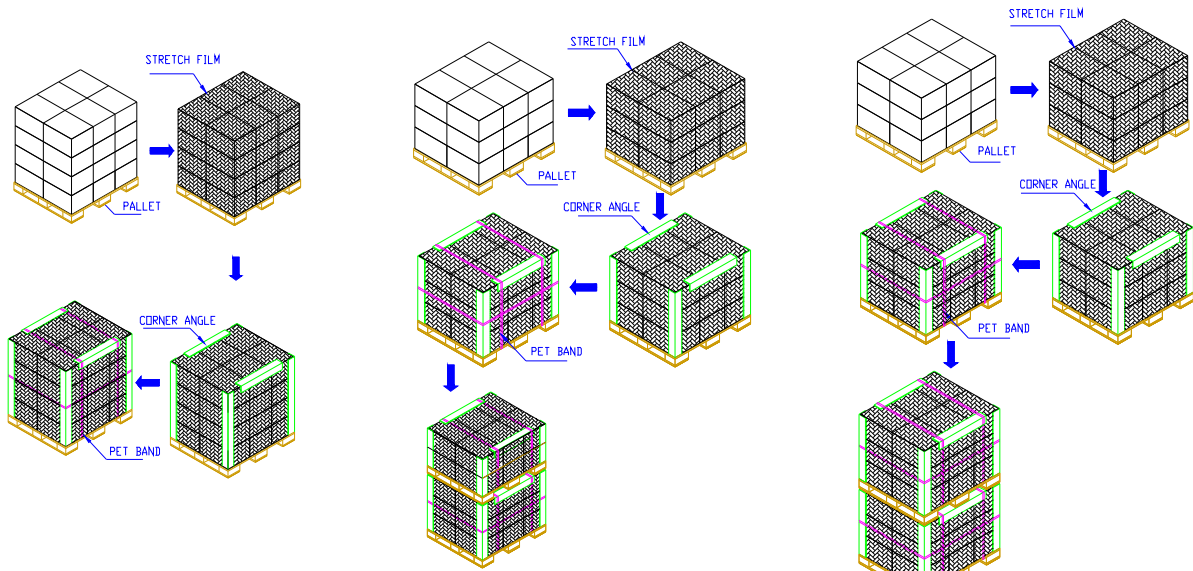

ONE PALLET SHIPMENT EXAMPLE SHIPPING BY AIR USED

TWO PALLETS SHIPMENT EXAMPLE SHIPPING BY SEA USED

TWO PALLETS SHIPMENT EXAMPLE SHIPPING BY SEA\_HQ USED

REV	DATE	DESCRIPTION	BY	CHK
01	2014-08-08	PACKAGE MARKING	WJ	WJ

1/1  
 AUO AU Optronics  
 04 1





## 10. Appendix: EDID Description

Address	FUNCTION	Value	Value	Value	Note
HEX		HEX	BIN	DEC	
00	Header	00	00000000	0	
01		FF	11111111	255	
02		FF	11111111	255	
03		FF	11111111	255	
04		FF	11111111	255	
05		FF	11111111	255	
06		FF	11111111	255	
07		00	00000000	0	
08	EISA Manuf. Code LSB	06	00000110	6	
09	Compressed ASCII	AF	10101111	175	
0A	Product Code	3D	00111101	61	
0B	hex, LSB first	11	00010001	17	
0C	32-bit ser #	00	00000000	0	
0D		00	00000000	0	
0E		00	00000000	0	
0F		00	00000000	0	
10	Week of manufacture	00	00000000	0	
11	Year of manufacture	16	00010110	22	
12	EDID Structure Ver.	01	00000001	1	
13	EDID revision #	04	00000100	4	
14	<b>Video input def.</b> ( <i>digital I/P, non-TMDS, CRGB</i> )	95	10010101	149	
15	<b>Max H image size</b> ( <i>rounded to cm</i> )	1F	00011111	31	
16	<b>Max V image size</b> ( <i>rounded to cm</i> )	11	00010001	17	
17	<b>Display Gamma</b> ( <i>=(gamma*100)-100</i> )	78	01111000	120	
18	<b>Feature support</b> ( <i>no DPMS, Active OFF, RGB, tmg Blk#1</i> )	02	00000010	2	
19	Red/green low bits ( <b>Lower 2:2:2 bits</b> )	87	10000111	135	
1A	Blue/white low bits ( <b>Lower 2:2:2 bits</b> )	E5	11100101	229	
1B	Red x ( <b>Upper 8 bits</b> )	A4	10100100	164	
1C	Red y/ highER 8 bits	56	01010110	86	
1D	Green x	50	01010000	80	
1E	Green y	9E	10011110	158	
1F	Blue x	26	00100110	38	
20	Blue y	0D	00001101	13	
21	White x	50	01010000	80	
22	White y	54	01010100	84	
23	Established timing 1	00	00000000	0	
24	Established timing 2	00	00000000	0	
25	Established timing 3	00	00000000	0	
26	Standard timing #1	01	00000001	1	
27		01	00000001	1	



# Product Specification

AU OPTRONICS CORPORATION

28	Standard timing #2	01	00000001	1
29		01	00000001	1
2A	Standard timing #3	01	00000001	1
2B		01	00000001	1
2C	Standard timing #4	01	00000001	1
2D		01	00000001	1
2E	Standard timing #5	01	00000001	1
2F		01	00000001	1
30	Standard timing #6	01	00000001	1
31		01	00000001	1
32	Standard timing #7	01	00000001	1
33		01	00000001	1
34	Standard timing #8	01	00000001	1
35		01	00000001	1
36	Pixel Clock/10000 LSB	14	00010100	20
37	Pixel Clock/10000 USB	37	00110111	55
38	Horz active <b>Lower 8bits</b>	80	10000000	128
39	Horz blanking <b>Lower 8bits</b>	B8	10111000	184
3A	HorzAct:HorzBlnk <b>Upper 4:4 bits</b>	70	01110000	112
3B	Vertical Active <b>Lower 8bits</b>	38	00111000	56
3C	Vertical Blanking <b>Lower 8bits</b>	24	00100100	36
3D	Vert Act : Vertical Blanking <b>(upper 4:4 bit)</b>	40	01000000	64
3E	HorzSync. Offset	10	00010000	16
3F	HorzSync.Width	10	00010000	16
40	VertSync.Offset : VertSync.Width	3E	00111110	62
41	Horz&Vert Sync Offset/Width <b>Upper 2bits</b>	00	00000000	0
42	Horizontal Image Size <b>Lower 8bits</b>	35	00110101	53
43	Vertical Image Size <b>Lower 8bits</b>	AD	10101101	173
44	Horizontal & Vertical Image Size <b>(upper 4:4 bits)</b>	10	00010000	16
45	Horizontal Border <i>(zero for internal LCD)</i>	00	00000000	0
46	Vertical Border <i>(zero for internal LCD)</i>	00	00000000	0
47	Signal <i>(non-intr, norm, no stero, sep sync, neg pol)</i>	18	00011000	24
48	Detailed timing/monitor	00	00000000	0
49	descriptor #2	00	00000000	0
4A		00	00000000	0
4B		0F	00001111	15
4C		00	00000000	0
4D		00	00000000	0
4E		00	00000000	0
4F		00	00000000	0
50		00	00000000	0
51		00	00000000	0
52		00	00000000	0
53		00	00000000	0
54		00	00000000	0
55		00	00000000	0
56		00	00000000	0



# Product Specification

AU OPTRONICS CORPORATION

57		00	00000000	0	
58		00	00000000	0	
59		20	00100000	32	
5A	Detailed timing/monitor	00	00000000	0	
5B	descriptor #3	00	00000000	0	
5C		00	00000000	0	
5D		FE	11111110	254	
5E		00	00000000	0	
5F	Manufacture	41	01000001	65	A
60	Manufacture	55	01010101	85	U
61	Manufacture	4F	01001111	79	O
62		0A	00001010	10	
63		20	00100000	32	
64		20	00100000	32	
65		20	00100000	32	
66		20	00100000	32	
67		20	00100000	32	
68		20	00100000	32	
69		20	00100000	32	
6A		20	00100000	32	
6B		20	00100000	32	
6C	Detailed timing/monitor	00	00000000	0	
6D	descriptor #4	00	00000000	0	
6E		00	00000000	0	
6F		FE	11111110	254	
70		00	00000000	0	
71	Manufacture P/N	42	01000010	66	B
72	Manufacture P/N	31	00110001	49	1
73	Manufacture P/N	34	00110100	52	4
74	Manufacture P/N	30	00110000	48	0
75	Manufacture P/N	48	01001000	72	H
76	Manufacture P/N	41	01000001	65	A
77	Manufacture P/N	4E	01001110	78	N
78	Manufacture P/N	30	00110000	48	0
79	Manufacture P/N	31	00110001	49	1
7A	Manufacture P/N	2E	00101110	46	.
7B	Manufacture P/N	31	00110001	49	1
7C		20	00100000	32	
7D		0A	00001010	10	
7E	Extension Flag	00	00000000	0	
7F	Checksum	A5	10100101	165	

Our company network supports you worldwide with offices in Germany, Austria, Switzerland, the UK and the USA. For more information please contact:

## Headquarters

Germany



**FORTEC Elektronik AG**

Lechwiesenstr. 9  
86899 Landsberg am Lech

Phone: +49 8191 91172-0  
E-Mail: [sales@forteca.de](mailto:sales@forteca.de)  
Internet: [www.forteca.de](http://www.forteca.de)

## Fortec Group Members

Austria



**FORTEC Elektronik AG**

**Office Vienna**

Nuschinggasse 12  
1230 Wien

Phone: +43 1 8673492-0  
E-Mail: [office@fortec.at](mailto:office@fortec.at)  
Internet: [www.fortec.at](http://www.fortec.at)

Germany



**Distec GmbH**

Augsburger Str. 2b  
82110 Germering

Phone: +49 89 894363-0  
E-Mail: [info@distec.de](mailto:info@distec.de)  
Internet: [www.distec.de](http://www.distec.de)

Switzerland



**ALTRAC AG**

Bahnhofstraße 3  
5436 Würenlos

Phone: +41 44 7446111  
E-Mail: [info@altrac.ch](mailto:info@altrac.ch)  
Internet: [www.altrac.ch](http://www.altrac.ch)

United Kingdom



**Display Technology Ltd.**

Osprey House, 1 Osprey Court  
Hichingbrooke Business Park  
Huntingdon, Cambridgeshire, PE29 6FN

Phone: +44 1480 411600  
E-Mail: [info@displaytechnology.co.uk](mailto:info@displaytechnology.co.uk)  
Internet: [www.displaytechnology.co.uk](http://www.displaytechnology.co.uk)

USA



**Apollo Display Technologies, Corp.**

87 Raynor Avenue,  
Unit 1 Ronkonkoma,  
NY 11779

Phone: +1 631 5804360  
E-Mail: [info@apolloDisplays.com](mailto:info@apolloDisplays.com)  
Internet: [www.apolloDisplays.com](http://www.apolloDisplays.com)