



Datasheet

ORTUSTECH

COM27H2P38UTC

The information contained in this document has been carefully researched and is, to the best of our knowledge, accurate. However, we assume no liability for any product failures or damages, immediate or consequential, resulting from the use of the information provided herein. Our products are not intended for use in systems in which failures of product could result in personal injury. All trademarks mentioned herein are property of their respective owners. All specifications are subject to change without notice.

Specifications for
Blanview TFT-LCD Monitor
(2.7" QVGA 240 x RGB x 320 Portrait)

Version 1.0

(Please be sure to check the specifications latest version.)

MODEL COM27H2P38UTC

Customer's Approval

Signature:

Name:

Section:

Title:

Date:

ORTUSTECH

ORTUS TECHNOLOGY CO., LTD.

Approved by

_____ *N. Konyu*

Checked by

_____ *Y. Saito*

Prepared by

_____ *M. Jojo*

ORTUS TECHNOLOGY CO.,LTD.

Contents

1. Application	3
2. Outline Specifications		
2.1 Features of the Product	4
2.2 Display Method	4
3. Dimensions and Shape		
3.1 Dimensions	6
3.2 Outward Form	7
3.3 Serial № print (S-print)	9
4. Pin Assignment	10
5. Absolute Maximum Rating	11
6. Recommended Operating Conditions	11
7. Characteristics		
7.1 DC Characteristics	12
7.2 AC Characteristics	13
8. Switching waveform	14
9. Input timing		
9.1 Input Timing Characteristics	15
9.2 Input Timing Chart	16
9.3 Input Timing example	17
10. Power-ON / Power-OFF sequence	18
11. Display-ON / Display-OFF sequence	19
12. Reset sequence	19
13. LED Circuit	20
14. Touch Panel Circuit	20
15. Characteristics		
15.1 Optical Characteristics	21
15.2 Temperature Characteristics	22
16. Criteria of Judgment		
16.1 Defective Display and Screen Quality	23
16.2 Screen and Other Appearance	24
17. Reliability Test	25
18. Packing Specifications	27
19. Handling Instruction		
19.1 Cautions for Handling LCD panels	28
19.2 Precautions for Handling	29
19.3 Precautions for Operation	29
19.4 Storage Condition for Shipping Cartons	30
19.5 Precautions for Peeling off the Protective film	31
19.6 Warranty	31
APPENDIX	32

1. Application

This Specification is applicable to 68.4mm (2.7 inch) Blanview TFT-LCD monitor with TP for non-military use.

- ◎ ORTUS TECHNOLOGY makes no warranty or assume no liability that use of this Product and/or any information including drawings in this Specification by Purchaser is not infringing any patent or other intellectual property rights owned by third parties, and ORTUS TECHNOLOGY shall not grant to Purchaser any right to use any patent or other intellectual property rights owned by third parties. Since this Specification contains ORTUS TECHNOLOGY's confidential information and copy right, Purchaser shall use them with high degree of care to prevent any unauthorized use, disclosure, duplication, publication or dissemination of ORTUS TECHNOLOGY'S confidential information and copy right.
- ◎ If Purchaser intends to use this Products for an application which requires higher level of reliability and/or safety in functionality and/or accuracy such as transport equipment (aircraft, train, automobile, etc.), disaster-prevention/security equipment or various safety equipment, Purchaser shall consult ORTUS TECHNOLOGY on such use in advance.
- ◎ This Product shall not be used for application which requires extremely higher level of reliability and/or safety such as aerospace equipment, telecommunication equipment for trunk lines, control equipment for nuclear facilities or life-support medical equipment.
- ◎ It must be noted as an mechanical design manner, especial attention in housing design to prevent arcuation/flexure or caused by stress to the LCD module shall be considered.
- ◎ ORTUS TECHNOLOGY assumes no liability for any damage resulting from misuse, abuse, and/or miss-operation of the Product deviating from the operating conditions and precautions described in the Specification.
- ◎ It shall be mutually conferred if nonconforming defect which result from unspecified cause in this specification arises.
- ◎ If any issue arises as to information provided in this Specification or any other information, ORTUS TECHNOLOGY and Purchaser shall discuss them in good faith and seek solution.
- ◎ ORTUS TECHNOLOGY assumes no liability for defects such as electrostatic discharge failure occurred during peeling off the protective film or Purchaser's assembly process.
- ◎ This Product is compatible for RoHS directive.

Object substance	Maximum content [ppm]
Cadmium and its compound	100
Hexavalent Chromium Compound	1000
Lead & Lead compound	1000
Mercury & Mercury compound	1000
Polybrominated biphenyl series (PBB series)	1000
Polybrominated biphenyl ether series (PBDE series)	1000

2. Outline Specifications

2.1 Features of the Product

- 2.7 inch diagonal display, 720 [H] x 320 [V] dots. 240RGB x 320 pixel.
- 6-bit / 262,144 colors.
- Single power supply operation of 3.0V.
- Timing generator [TG], Counter-electrode driving circuitry, Built-in power supply circuit.
- Long life & High bright white LED back-light and Touch panel operation monitor.
- Blanview TFT-LCD, improved outdoor visibility.

	Indoor		Outdoor	
	Visibility	Power Efficiency (Battery Life)	Visibility	Power Efficiency (Battery Life)
Transmissive	Good	Good	Fair	Poor
Transflective	Fair	Poor	Good	Good
Blanview	Good	Good	Good	Good

2.2 Display Method

Items	Specifications	Remarks
Display type	VA type 262,144 colors Blanview, Normally Black	
Driving method	a-Si TFT Active matrix Line-scanning, Non-interlace	
Dot arrangement	RGB stripe arrangement	Refer to "Dot arrangement"
Signal input method	6-bit Data : Paralell interface	
Backlight type	Long life & High bright white LED	
Touch panel	Resistance type,transmissive analog tablet	Surface finishing:Clear
NTSC ratio	50%	

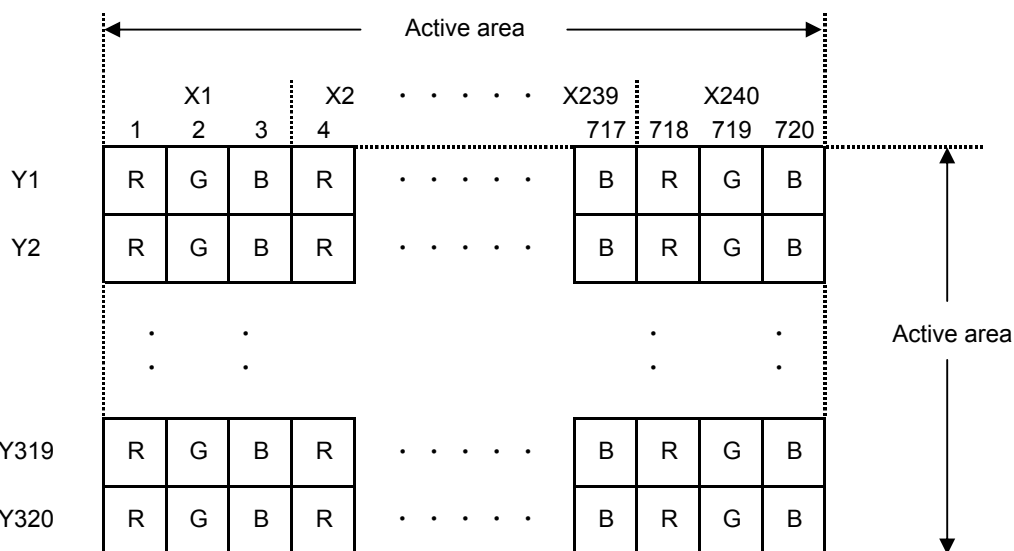

Dot arrangement (FPC cable placed lower side)

<Features of Blanview>

- Backlight power consumption required to assure visibility. (equivalent to 3.5"QVGA)

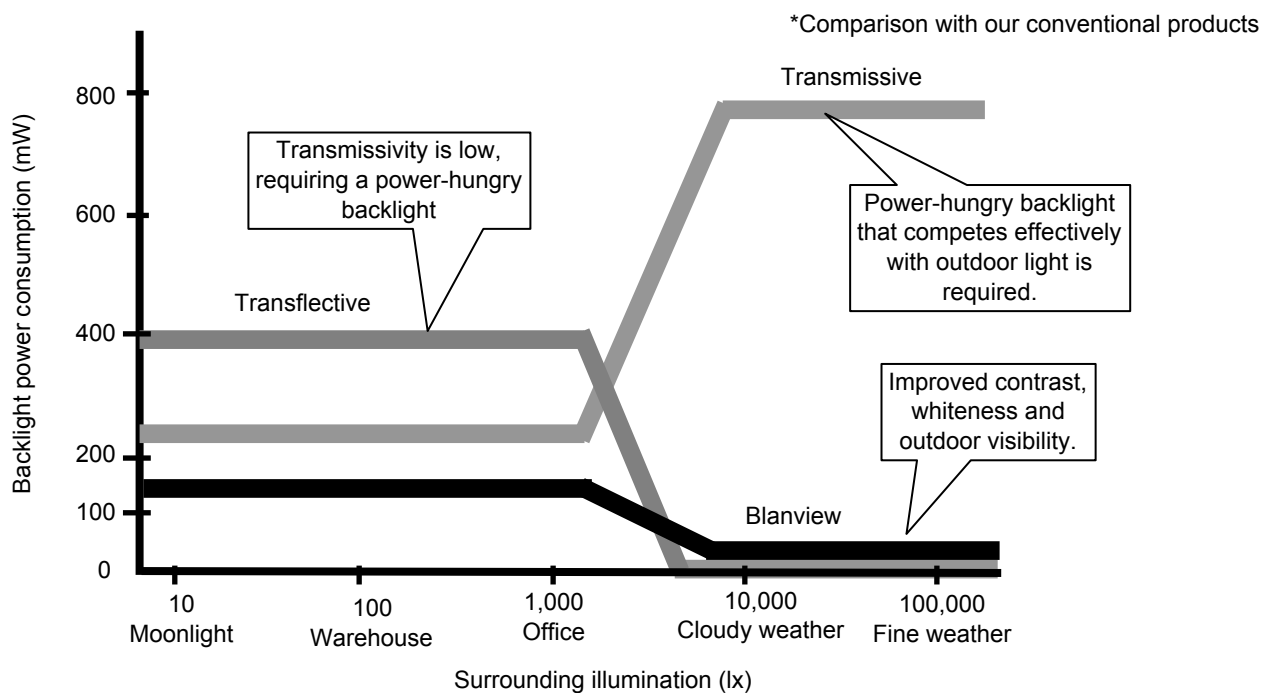

- Contrast characteristics under 100,000lx. (same condition as direct sunlight.)

With better contrast (higher contrast ratio), Blanview TFT-LCD has the best outdoor visibility in three different types of TFT-LCD.

Below chart shows contrast value against panel surface brightness. (Horizontal: Panel surface brightness/ Vertical: Contrast value) LCD panel has enough outdoor visibility above our Standard line. (ORTUS TECHNOLOGY criteria)

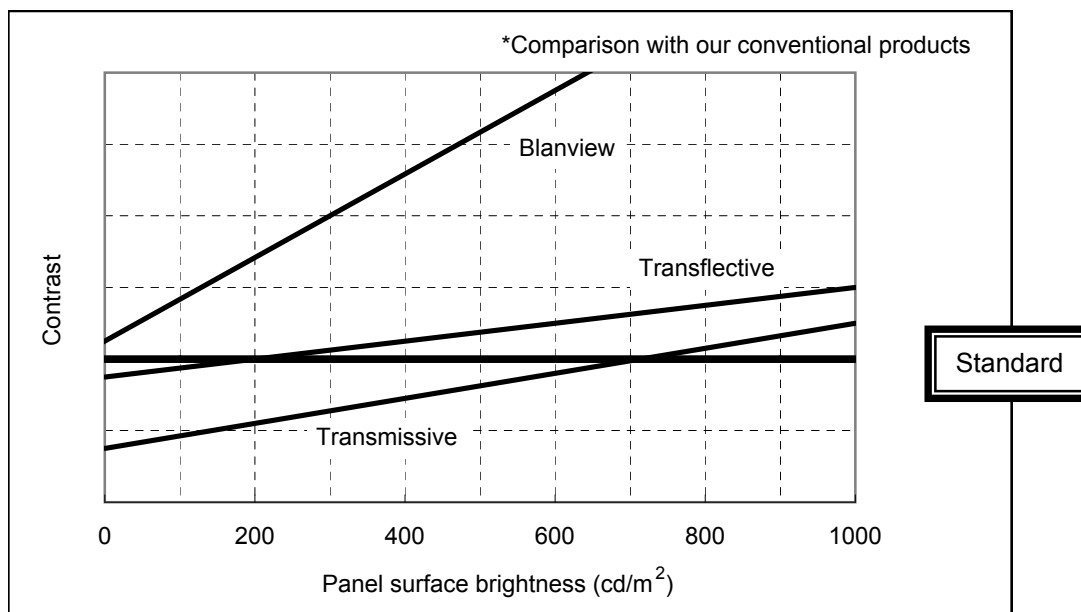

3. Dimensions and Shape

3.1 Dimensions

Items	Specifications	Unit	Remarks
Outline dimensions	47.00[H] × 66.00[V] × 4.19[D]	mm	exclude FPC and components on the FPC
Active area	41.04[H] × 54.72[V]	mm	68.4mm diagonal
Number of dots	720[H] × 320[V]	dot	
Dot pitch	57.0[H] × 171.0[V]	um	
Hardness of Touch Panel surface	3	H	
Weight	25.0	g	Include FPC cable

3.2 Outward Form

(7/37)
16TLM010
Issue: May. 12, 2016

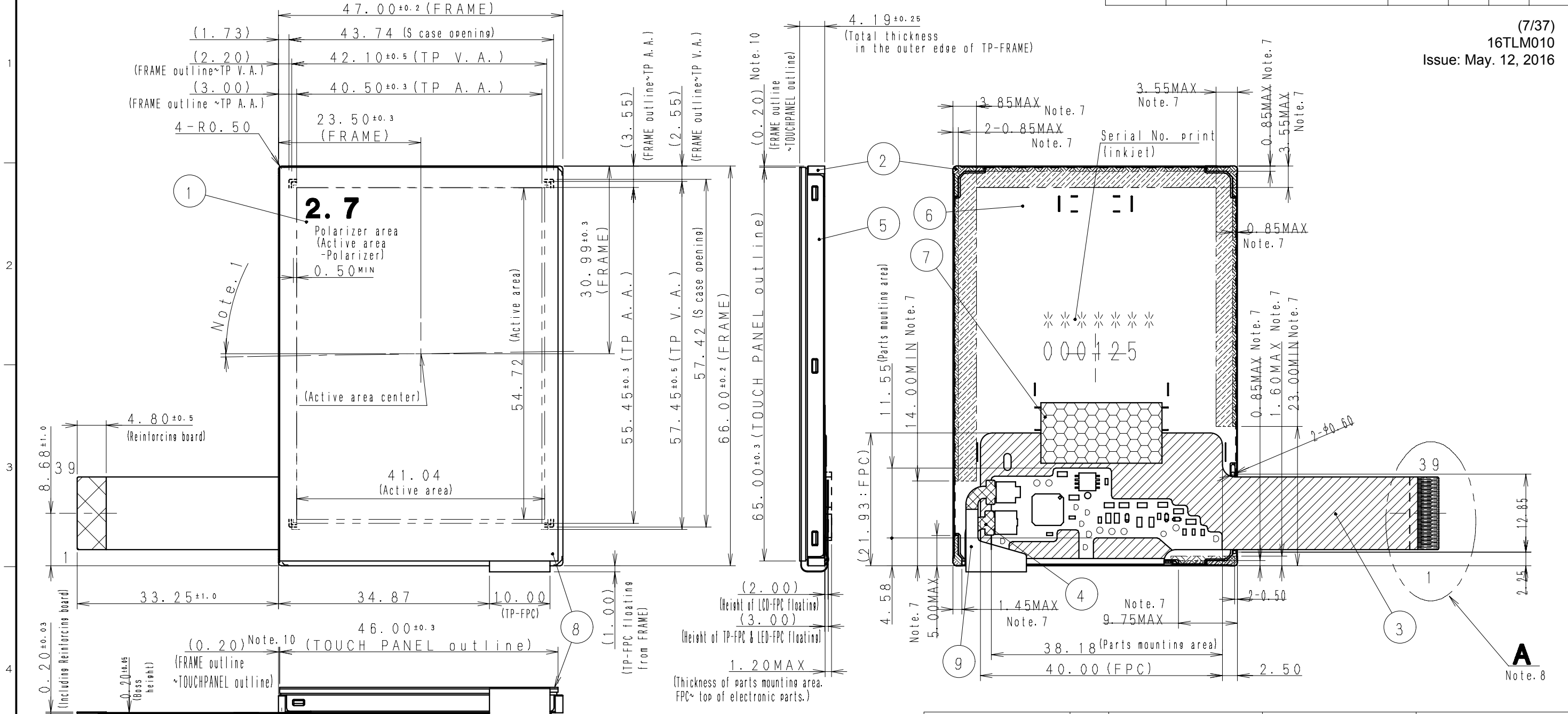

- Note 1. Angular deviation of LCD cell from the TFT-LCD monitor's reference axis shall be less than $[\pm 40']$.
- Note 2. Recommended FPC connectors
For LCD : HIROSE, part number: FH23-39S-0.3SHW (05)
- Note 3. Protective film is affixed on front surface of the screen.
Location tolerance of the protective film shall be ± 1.5 mm to the TOUCHPANEL.
- Note 4. Keep a gap, for example 0.3 to 0.7mm between the bezel edge and T/P surface to avoid the bezel edge from making contacting with the T/P surface that may cause a "false touch" with the bottom layer.
- Note 5. Bezel Opening design:
It is recommended to design based on LCD Active area and LCD Active area center.
Please place the bezel opening to maintain the operation by a stylus pen or finger inside the T/P response area. (Refer to "Example of housing design")
The dimensions shown (note6) in drawing are One example of the bezel design.
- Note 6. Linearity is guaranteed in the area surrounded by 3mm inside lines from TOUCHPANEL Active Area.
- Note 7. In case TFT-LCD monitor is fixed to the case of your product, it's recommended that monitor is fixed in to area. If the burden on area are smaller than area, these area can be used too.
- Note 8. Refer to "4. PIN ASSIGNMENT" about the pin No. of TOUCHPANEL.
- Note 9. Refer to "16. CRITERIA OF JUDGMENT" about the appearance specification of a polarizer.
- Note 10. Touch Panel fits in the outer shape of the frame.

	10		
TP-FPC	9		
TOUCH PANEL	8		Glass substrate thickness=0.7t
I-TAPE	7		t = 0.05
S CASE C	6		SUS304
S CASE A	5		SUS304
LED-FPC	4		
LCD-FPC	3		
FRAME	2		PC
LCD	1		Glass substrate thickness=0.5t

PART NAME		ITEM	MATERIAL GRADE	REMARK
APPROVED	GENERAL TOLERANCE ± 0.5	SCALE FREE (2/1)	UNIT mm	ORTUSTECH ORTUS TECHNOLOGY CO., LTD. DO NOT DUPLICATE, CONFIDENTIAL AND PROPRIETARY
CHECKED	ISSUE (Y:M:D) 16:02:25	MODEL COM27H2P38U**		
CHECKED	NAME			DRAWING No.
DESIGN 小林宣幸				REV.
DRAW 小林宣幸				SHEET
				DIV.

OUTLINE-D2P38

RJD527952D301 1/2

EC No.	REV.No.	REVISE	DATE (Y:M:D)	APPROVED	CHECKED	PREPARED
--------	---------	--------	--------------	----------	---------	----------

(8/37)
16TLM010
Issue: May. 12, 2016

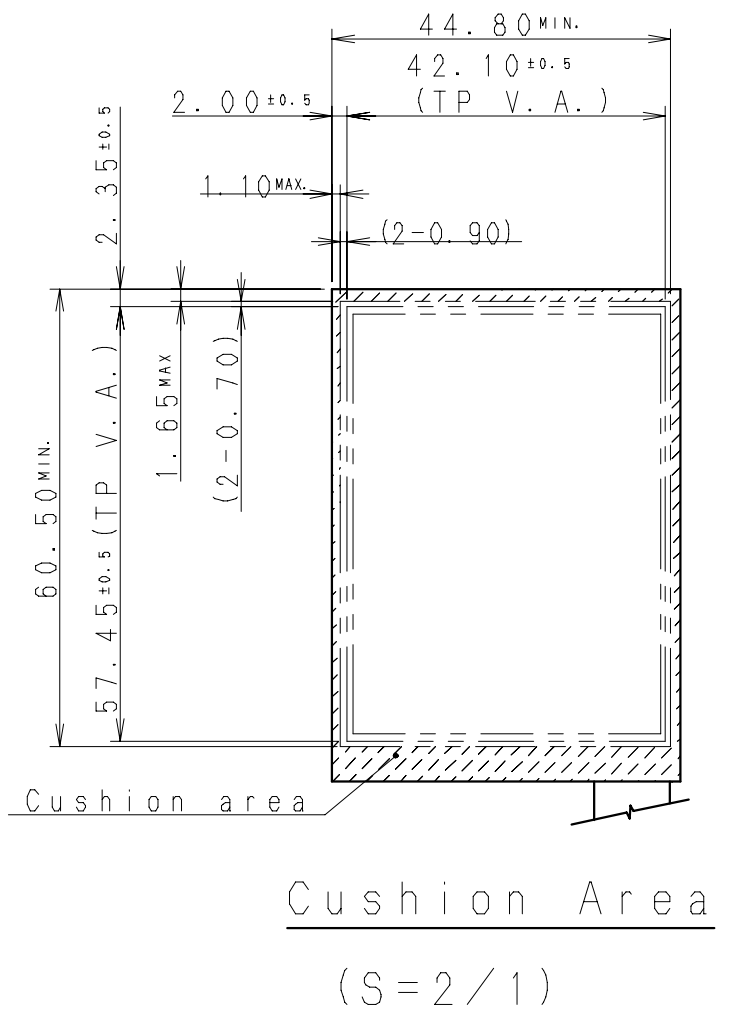
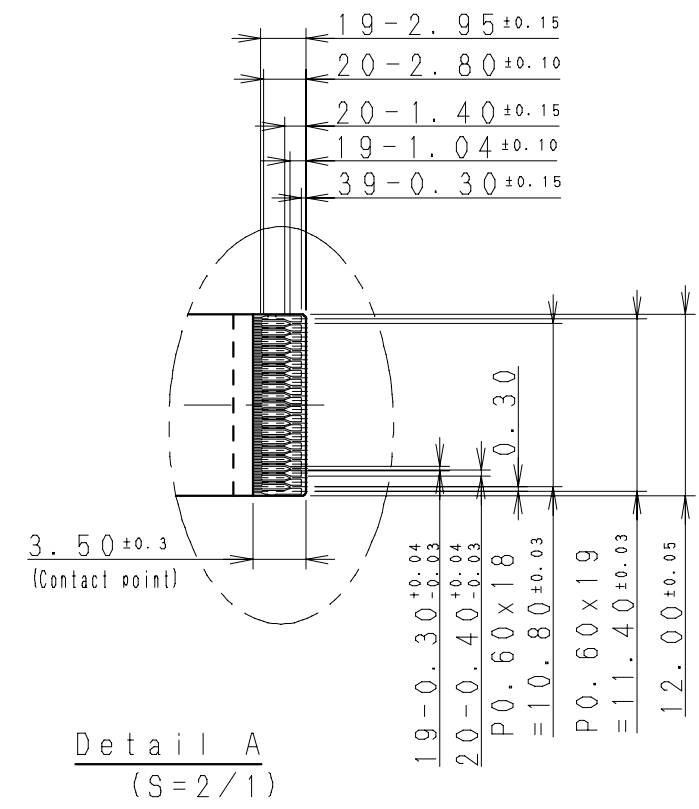

Example of Housing Design

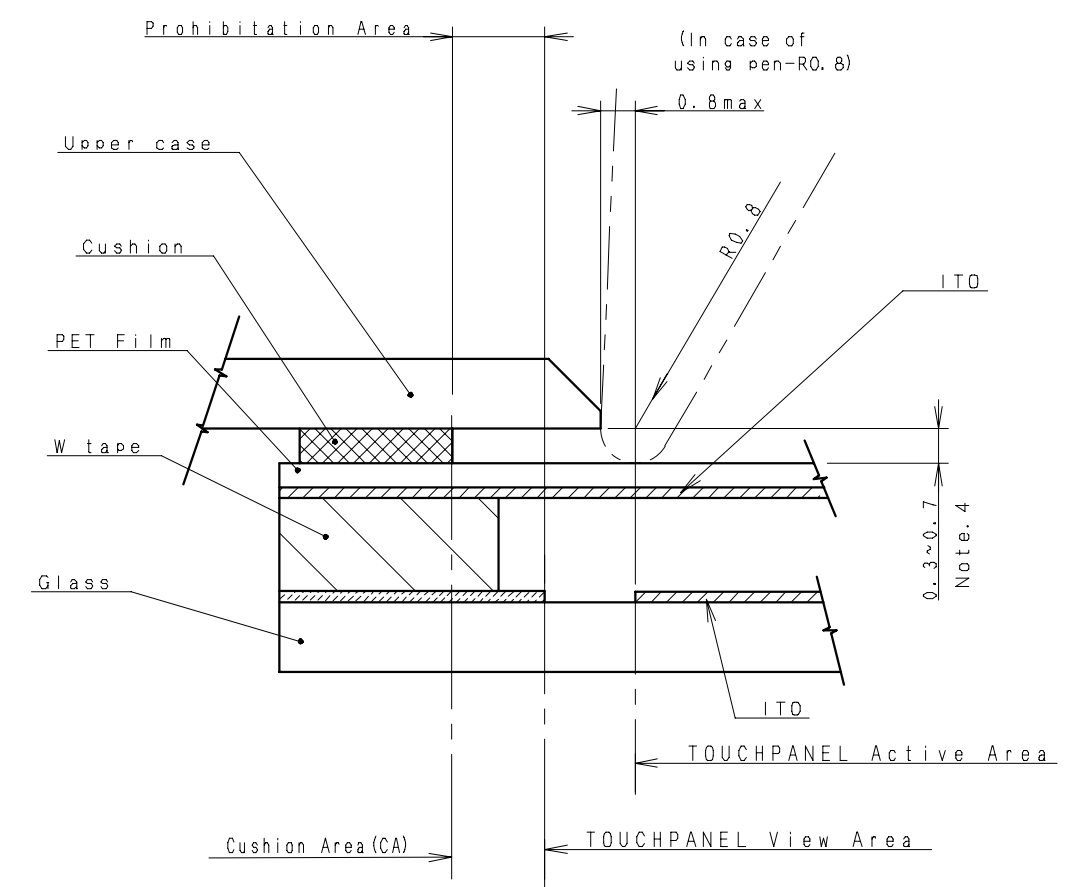

Design guidance for the upper case & the cushion

- Note 11. Upper case opening
a. Please place the upper case opening to maintain the operation by a stylus pen inside the TP response area
b. Please use the appropriate material (PMMA, PC, etc.) as the upper case.
- Note 12. Cushion design
a. Please put the cushion on the upper case.
b. Do not use an adhesive tape to stick on the TP surface.
c. Please position the cushion over the cushion area to avoid a short.

APPROVED	GENERAL TOLERANCE ±0.5	SCALE FREE	UNIT mm	ORTUSTECH ORTUS TECHNOLOGY CO., LTD. DO NOT DUPLICATE, CONFIDENTIAL AND PROPRIETARY		
CHECKED	ISSUE (Y:M:D) 16:02:25	MODEL COM27H2P38U**				
CHECKED	NAME			DRAWING No.		
DESIGN 小林宣幸	OUTLINE-D2P38			REV.	SHEET	DIV.
DRAW 小林宣幸				RJD527952D301	2/2	

3.3 Serial № print (S-print)

1) Display Items

S-print indicates the least significant digit of manufacture year (1digit), manufacture month with below alphabet (1letter), model code (5characters), serial number (6digits).

* Contents of Display

*	*	*****	*****
-	-	-	-
a	b	c	d

Contents of display				
a	The least significant digit of manufacture year			
b	Manufacture month	Jan-A Feb-B Mar-C Apr-D	May-E Jun-F Jul-G Aug-H	Sep-I Oct-J Nov-K Dec-L
c	Model code	27GGC (Made in Japan) 27GHC (Made in Malaysia)		
d	Serial number			

* Example of indication of Serial № print (S-print)

•Made in Japan

7J27GGC000125

means "manufactured in October 2017, 2.7" GG type, C specifications, serial number 000125"

•Made in Malaysia

7J27GHC000125

means "manufactured in October 2017, 2.7" GH type, C specifications, serial number 000125"

2) Location of Serial № print (S-print)

Refer to 3.2 "Outward Form".

3)Others

Please note that it is likely to disappear with an organic solvent about the Serial print.

4. Pin Assignment

No.	Symbol	Function	I/O
1	VSS	GND	P
2	VSS	GND	P
3	VDD	Power supply	P
4	VDD	Power supply	P
5	VSS	GND	P
6	RESETB	Reset signal (Lo-active)	I
7	HSYNC	Horizontal synchronization signal (Negative polarity)	I
8	VSYNC	Vertical synchronizing signal (Negative polarity)	I
9	CLK	Display clock (Falling read)	I
10	VSS	GND	P
11	D00	Display data (B) input It becomes black display in 00h. D00:LSB D05:MSB gamma conversion internally driver.	I
12	D01		I
13	D02		I
14	D03		I
15	D04		I
16	D05		I
17	D10	Display data (G) input It becomes black display in 00h. D10:LSB D15:MSB gamma conversion internally driver.	I
18	D11		I
19	D12		I
20	D13		I
21	D14		I
22	D15		I
23	D20	Display data (R) input It becomes black display in 00h. D20:LSB D25:MSB gamma conversion internally driver.	I
24	D21		I
25	D22		I
26	D23		I
27	D24		I
28	D25		I
29	VSS	GND	P
30	DE	Input data valid signal (Hi-active)	I
31	STBYB	Standby control signal (Lo: Standby, Hi: Normal-operation)	I
32	TEST1	MODE1 (GND connection)	I
33	XL	X-axis left terminal	I/O
34	YD	Y-axis down terminal	I/O
35	XR	X-axis right terminal	I/O
36	YU	Y-axis up terminal	I/O
37	TEST2	MODE2 (GND connection)	I
38	BLH	LED drive power source. (Anode side)	P
39	BLL	LED drive power source. (Cathode side)	P

Note :

- Recommended connector : Hirose FH23 series "FH23-39S-0.3SHW(05) "
- Terminal arrangement, please refer to "3.2 Outward Form".
- FPC of the terminal has been decorated with gold-plated.
Connector contact terminals is recommended the use of gold-plated products.

5. Absolute Maximum Rating

VSS=0V

Item	Symbol	Condition	Rating		Unit	Applicable terminal
			MIN	MAX		
Supply voltage	VDD	Ta=25°C	-0.3	4.6	V	VDD
Input voltage for logic	VI		-0.3	VDD+0.3	V	CLK,VSYNC,HSYNC,DE D[05:00],D[15:10],D[25:20] ,STBYB,RESETB,TEST1,TEST2
LED Forward current	IL	Ta = 25°C	—	35.0	mA	BLH - BLL
		Ta = 70°C	—	15.0		
Touch Panel input voltage	VIT		—	7.0	V	XR,XL,YU,YD
Storage temperature range	Tstg		-30	80	°C	
Storage atmospheric range	Hstg	40°C90%RH or less of moisture content with no condensation				

6. Recommended Operating Conditions

VSS=0V

Item	Symbol	Condition	Rating			Unit	Applicable terminal
			MIN	TYP	MAX		
Supply voltage	VDD		2.7	3.0	3.6	V	VDD
Input voltage for logic	VI		0	—	VDD	V	CLK,VSYNC,HSYNC,DE, D[05:00],D[15:10],D[25:20], STBYB,RESETB, TEST1,TEST2
Operational temperature range	Top	*note	-20	+25	+70	°C	Touch Panel surface temperature
Operating humidity range	Hop	Ta ≤ 40°C	20	—	85	%	
		Ta > 40°C	40°C85%RH or less of moisture content with no condensation				

note : The maximum value of LED Forward current "IL", do not exceed the following allowable current value.

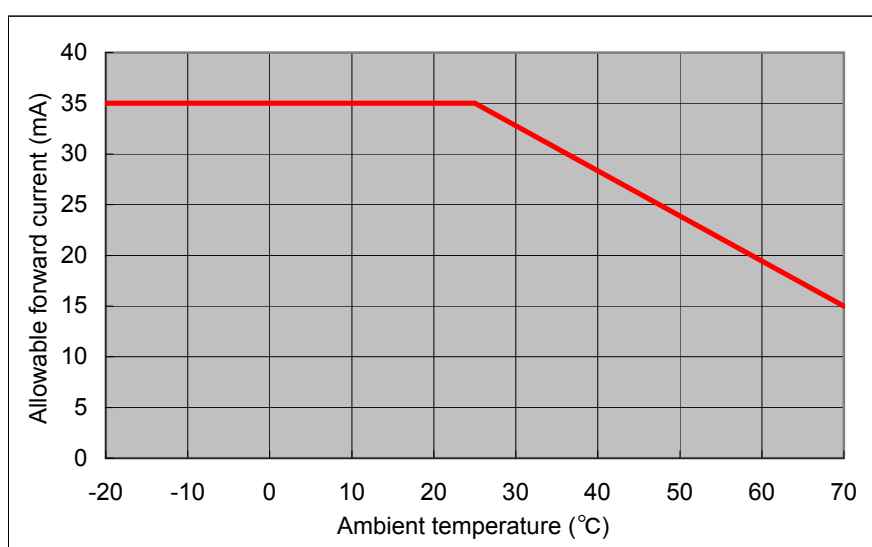

7. Characteristics

7.1 DC Characteristics

7.1.1 Display section

(Unless otherwise noted, Ta=25°C, VDD=3.0V, VSS=0V)

Item	Symbol	Condition	Rating			Unit	Applicable terminal
			MIN	TYP	MAX		
Input Signal Voltage	VIH		0.7×VDD	—	VDD	V	CLK, VSYNC, HSYNC, DE
	VIL		0	—	0.3×VDD	V	STBYB, RESETB D[05:00], D[15:10], D[25:20] TEST1, TEST2
Operating Current	IDD	fCLK=6.25MHz Color bar display	—	9.2	18.4	mA	VDD

7.1.2 Backlight section

Item	Symbol	Condition	Rating			Unit	Applicable terminal
			MIN	TYP	MAX		
Forward current	IL25	Ta=25°C	—	7.0	35.0	mA	BLH — BLL
	IL70	Ta=70°C	—	—	15.0	mA	
Forward voltage	VL	Ta=25°C, IL=7.0mA	—	8.0	8.5	V	
Estimated Life of LED	LL	Ta=25°C, IL=7.0mA *note	—	50,000	—	hr	

- note : - The lifetime of the LED is defined as a period till the brightness of the LED decreases to the half of its initial value.
 - This figure is given as a reference purpose only, and not as a guarantee.
 - This figure is estimated for an LED operating alone.
 As the performance of an LED may differ when assembled as a monitor together with a TFT panel due to different environmental temperature.
 - Estimated lifetime could vary on a different temperature and usually higher temperature could reduce the life significantly.

7.1.3 Touch Panel

Ta=25°C

Item	Symbol	Condition	Rating			Unit	Applicable terminal
			MIN	TYP	MAX		
Linearity	LE	Note	-1.5	--	1.5	%	
Insulation resistance	RI	DC 25V	20	--	--	MΩ	XR, XL-YU, YD
Terminal resistance		X	200	--	900	Ω	XR, XL
		Y	200	--	900		YU, YD
Rated voltage		DC	--	5.0	7.0	V	XR, XL, YU, YD
on/off chattering		R0.8mm Polyacetal pen.	--	--	10	ms	

Note: -Linearity Measurement: Refer to the APPENDIX of "Reference Method for Measuring Optical Characteristics and Performance".
 Load: 2.45N

Mechanical Characteristics

Item	Rating			Unit	Remark
	MIN	TYP	MAX		
Detectable activation force	0.05	--	0.80	N	R0.8mm Polyacetal pen or finger. Resistance between X and Y axis must be equal or lower than 2KΩ.
Keystroke durability	1,000,000	--	--	times	key the same part by silicon rubber. (Touch panel Active area only) -Rubber tip part: R8mm -Load: 2.45N -speed: 2times/second

7.2 AC Characteristics

(Unless otherwise noted, $T_a=25^{\circ}\text{C}$, $V_{DD}=3.0\text{V}$, $V_{SS}=0\text{V}$)

Item	Symbol	Condition	Rating			Unit	Applicable terminal
			MIN	TYP	MAX		
CLK frequency	fCLK		4.4	5.6	7.0	MHz	CLK
CLK Lo period	tw1L	0.3×VDD or less of the period	15	—	—	ns	CLK
CLK Hi period	tw1H	0.7×VDD or less of the period	15	—	—	ns	CLK
Input setup time	tsp		15	—	—	ns	HSYNC, VSYNC, CLK, DE
Input hold time	thd		15	—	—	ns	D[05:00], D[15:10], D[25:20]

note :

- All timing is specified in 30-70% of VDD.
- Tf / tf of the input signal is specified in the 15ns or less.

8. Switching waveform

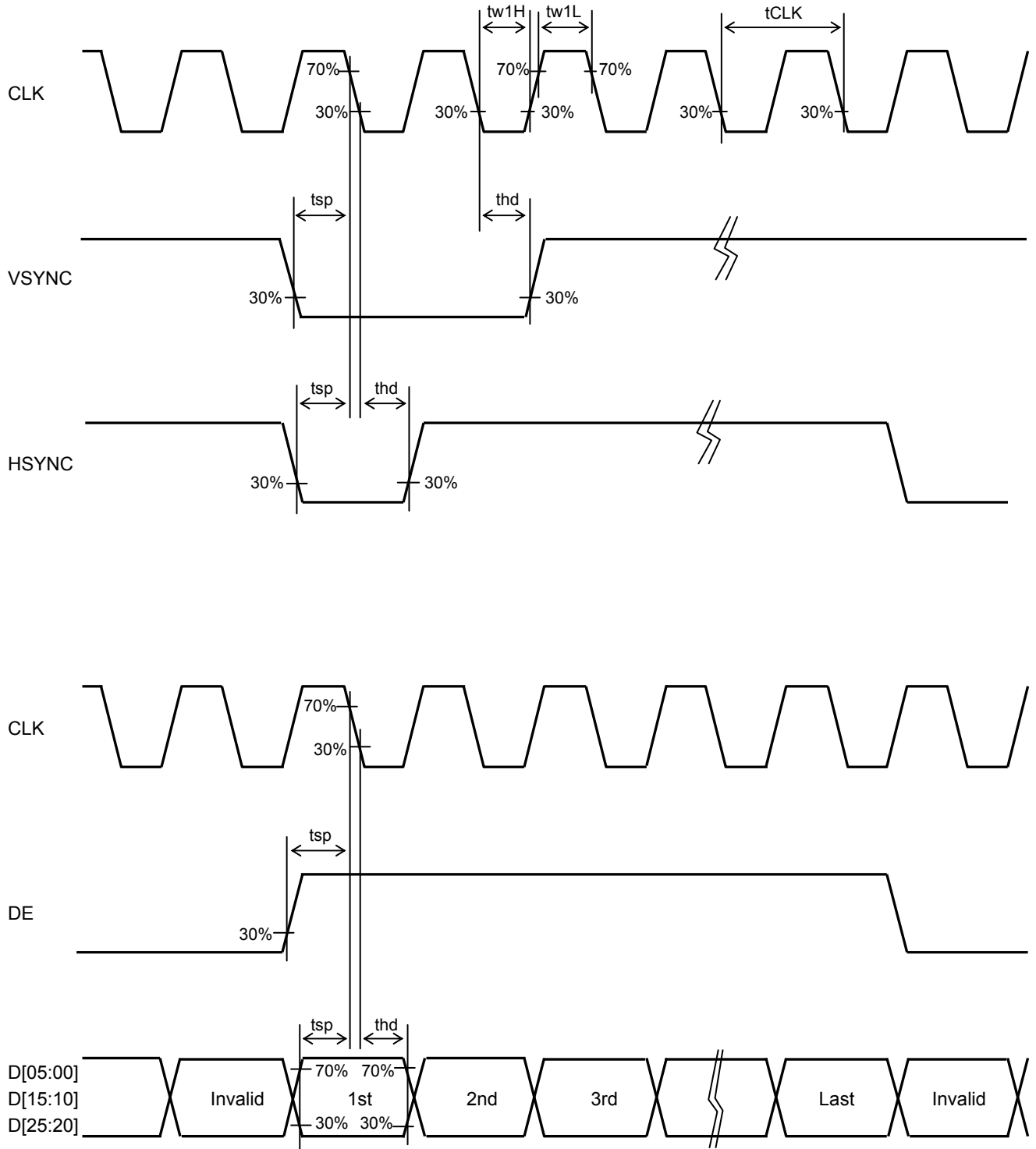

9. Input timing

9.1 Input timing characteristics

(Unless otherwise noted, Ta=25°C, VDD=3.0V, VSS=0V)

Item	Symbol	Rating			Unit	Applicable terminal
		MIN	TYP	MAX		
CLK frequency	fCLK	4.4	5.6	7.0	MHz	CLK
VSYNC frequency *note	fVSYNC	54	60	66	Hz	VSYNC
VSYNC signal period	tv	324	325	348	H	VSYNC, HSYNC
VSYNC pulse width	tw2H	1	—	—	H	VSYNC, HSYNC
Vertical back porch	tvb	2	—	14	H	VSYNC, HSYNC, D[05:00], D[15:10], D[25:20]
Vertical display period	tvdP	—	320	—	H	VSYNC, HSYNC, D[05:00], D[15:10], D[25:20]
HSYNC frequency	fHSYNC	—	19.5	—	kHz	HSYNC
HSYNC signal period	th	—	287	402	CLK	HSYNC, CLK
HSYNC pulse width	tw3H	1	—	—	CLK	HSYNC, CLK
Horizontal back porch	thb	2	—	14	CLK	HSYNC, CLK, D[05:00], D[15:10], D[25:20]
DE pulse width	tw4H	—	240	—	CLK	DE, CLK
Horizontal display period	thdp	—	240	—	CLK	D[25:00], CLK

note : Characteristic of this item is the recommended standard.

When used in outside this property, Please use after confirming a sufficient display quality, etc.

9.2 Input timing chart

I. Vertical drive timing

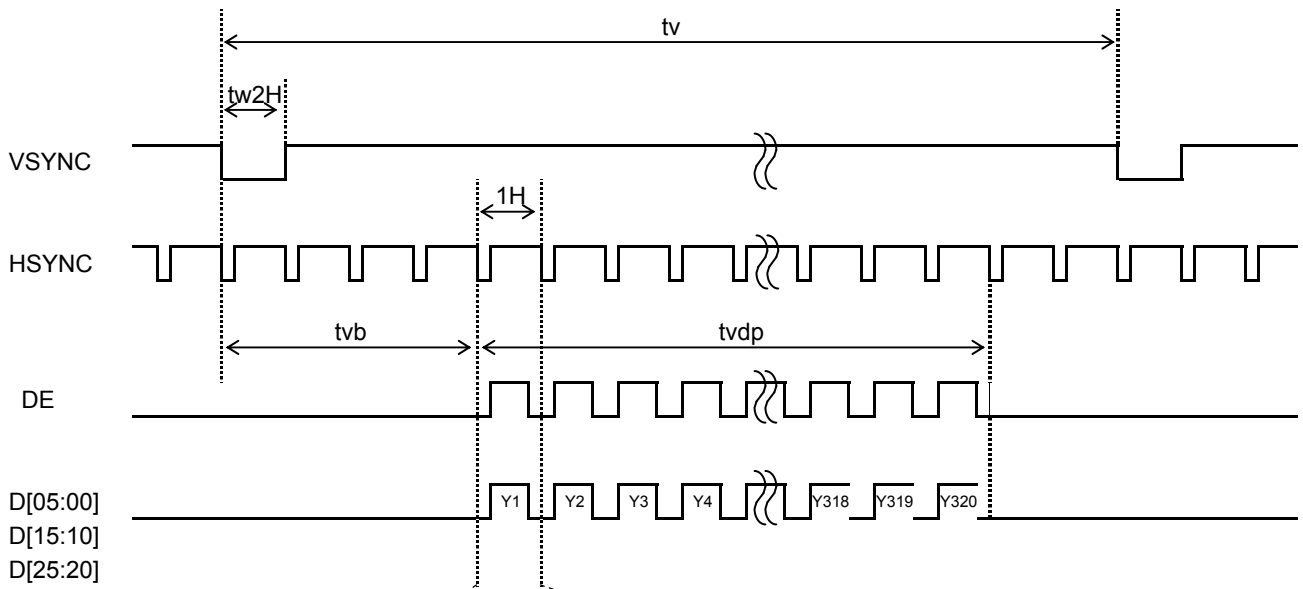

II. Horizontal drive timing

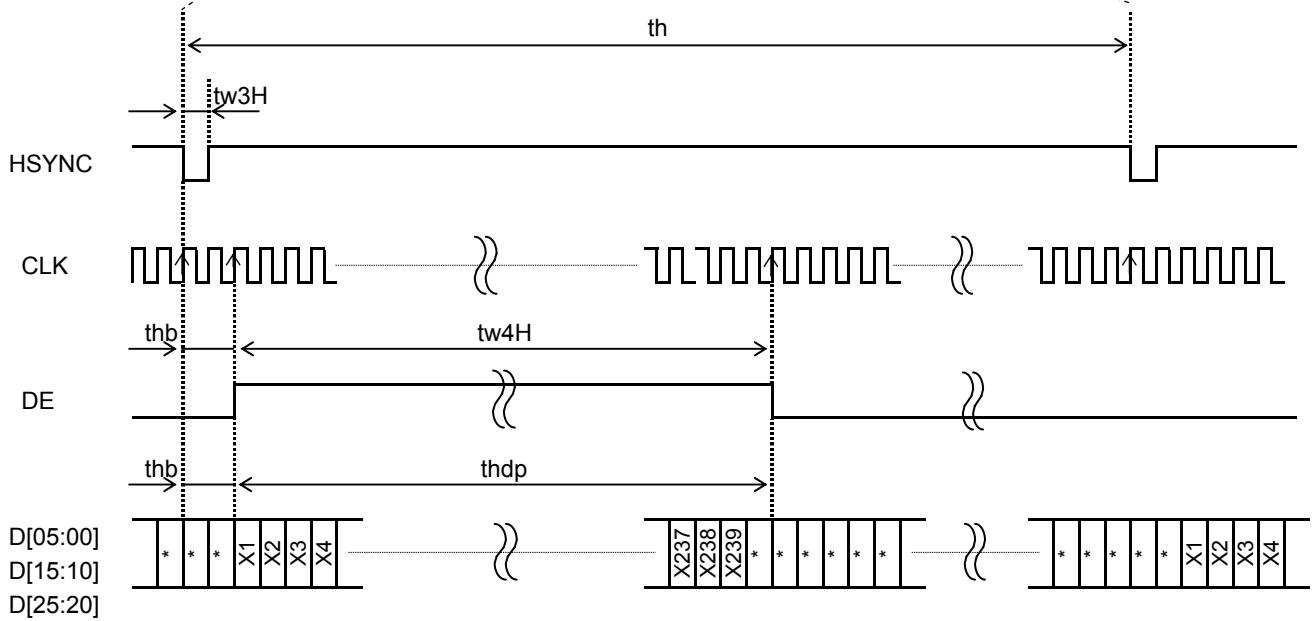

9.3 Input timing example (fCLK = 5.0MHz, 5.6MHz, 6.25MHz)

I. Vertical drive timing

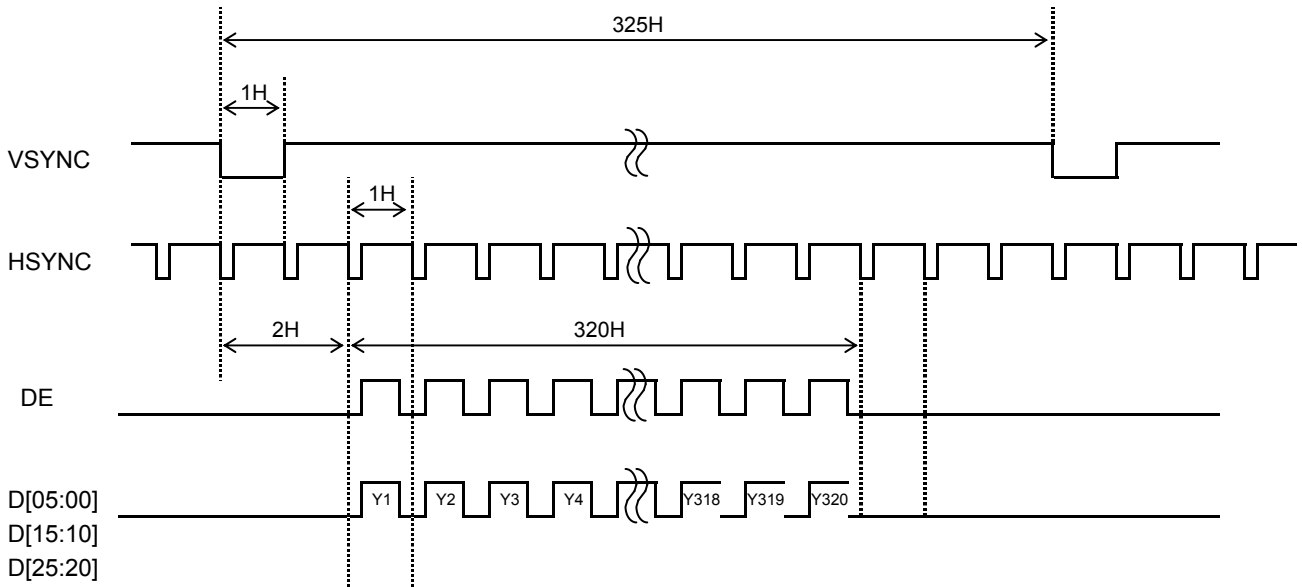

II. Horizontal drive timing

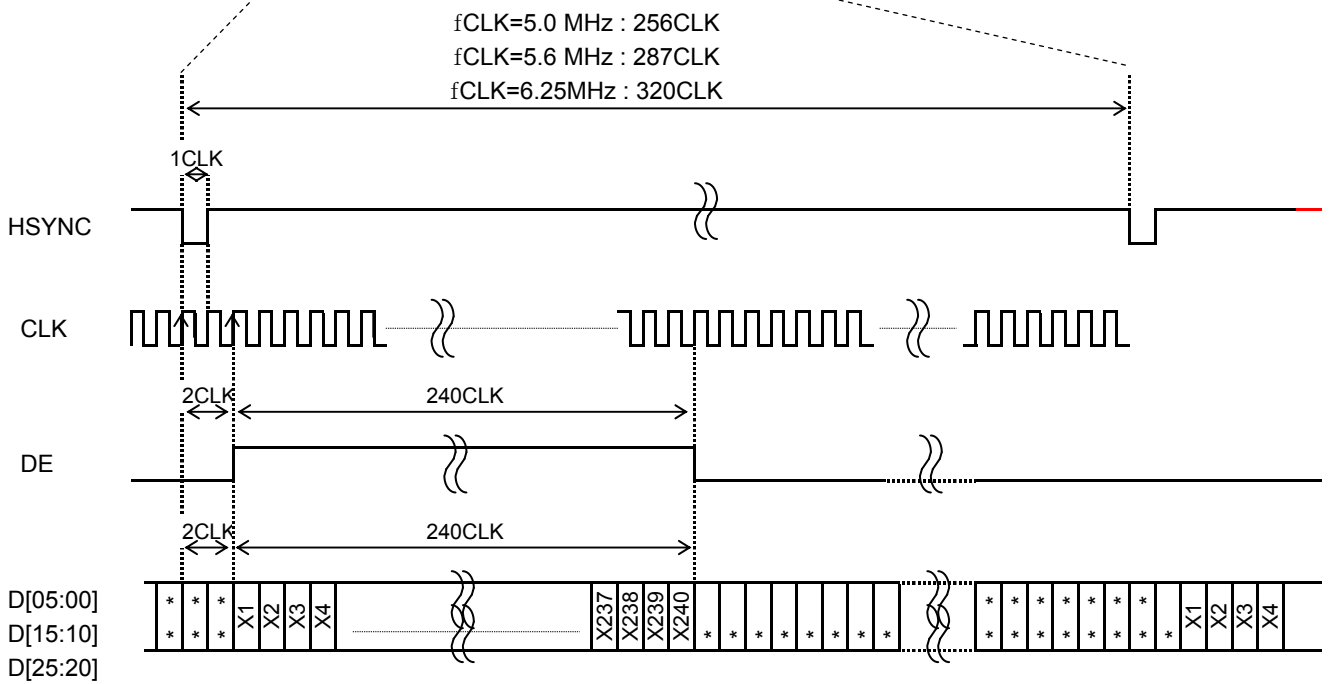

10. Power-ON / Power-OFF sequence

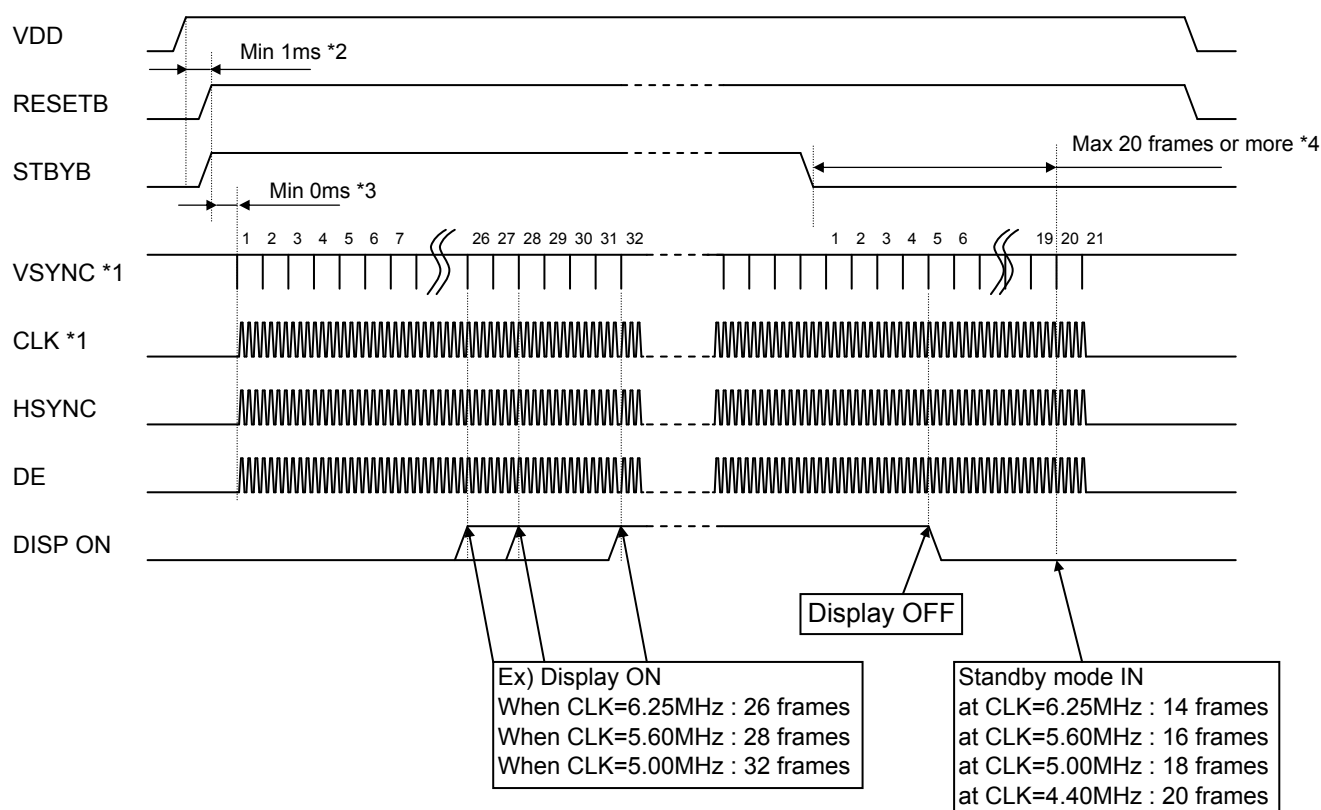

*1 Operation CLK of GA (gate array) on the FPC uses the CLK (DOTCLK).

In addition, the internal counter of GA also uses VSYNC.

It will start the operation after the CLK and VSYNC is input

*2 After the power is turned on, run the RESETB sure. (Please refer to "12.Reset sequence")

*3 Although there are no provisions in the time from RESETB "H" to each signal is inputted, each signal of that period must be fixed to "Hi" or "Lo" level.

*4 To turn OFF the power supply so that there is no afterimage, up to 20 frames or more of the period from STBYB "Low", is required supply of VSYNC and CLK(DOTCLK).

11. Display-ON / Display-OFF sequence

We'll explain about the display sequence at the time of display ON / OFF by STBYB signal
From the standby release until the display is started, according to the CLK period, you will need time below.

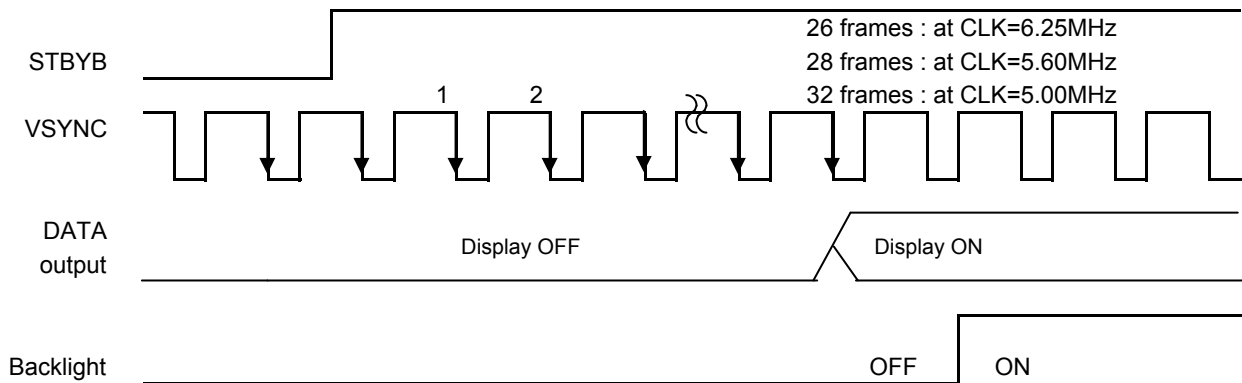

From the standby setting to standby sequence end, depending on the CLK period, you will need time below.
That period, there is a need to continue to supply the DOTCLK and VSYNC signal.
Within the provisions frame, if you stop the DOTCLK and VSYNC signal or turn OFF the power, there is a possibility that afterimage occurs.

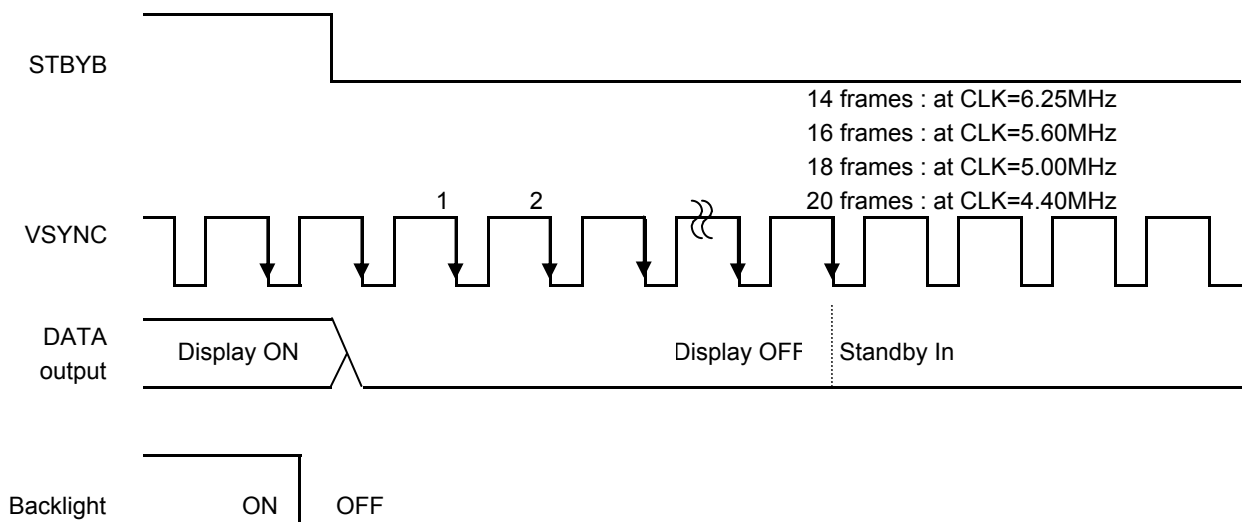

12. Reset sequence

Between the power is turned on and the RESET input is limited.
Please be sure to meet the following conditions.

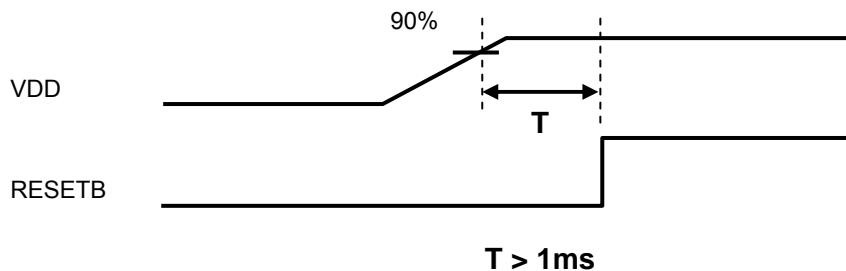

13. LED Circuit

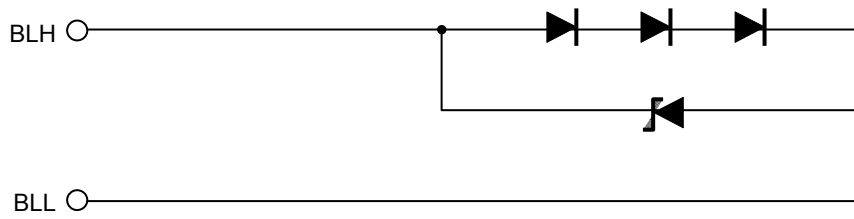

14. Touch Panel Circuit

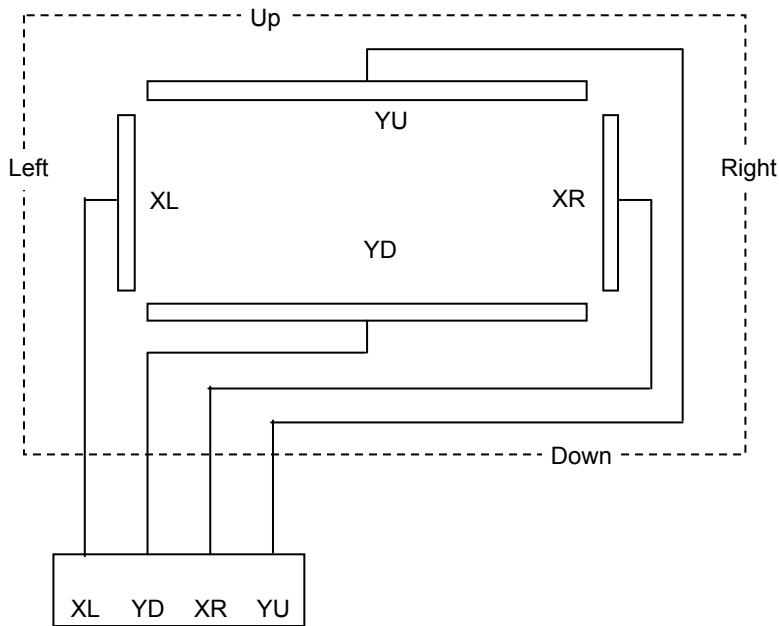

15. Characteristics

15.1 Optical Characteristics

< Measurement Condition >

Measuring instruments: CS1000 (KONICA MINOLTA) , LCD7200(OTSUKA ELECTRONICS) ,
EZcontrast160D (ELDIM)

Driving condition: VDD = 3.0V, VSS = 0V
Optimized VCOMDC

Backlight: IL=7.0mA

Measured temperature: Ta=25° C

Item		Symbol	Condition	MIN	TYP	MAX	Unit	Note No.	Remark
Response time	Rise time	TON	[Data]= 00h → 3Fh	—	—	60	ms	1	
	Fall time	TOFF	[Data]= 3Fh → 00h	—	—	40	ms		
Contrast ratio	Backlight ON	CR	[Data]= 3Fh / 00h	400	800	—		2	
	Backlight OFF			—	2	—			
Viewing angle	Left	θL	[Data]= 3Fh / 00h CR ≥ 10	80	—	—	deg	3	
	Right	θR		80	—	—	deg		
	Up	φU		80	—	—	deg		
	Down	φD		80	—	—	deg		
White Chromaticity	x		Refer to White chromaticity range					4	
	y								
Burn-in				No noticeable burn-in image shall be observed after 2 hours of window pattern display.				5	
Center brightness			[Data]=3Fh	200	280	—	cd/m ²	6	
Brightness distribution			[Data]=3Fh	70	—	—	%	7	

* Note number 1 to 7: Refer to the APPENDIX of "Reference Method for Measuring Optical Characteristics and Performance".

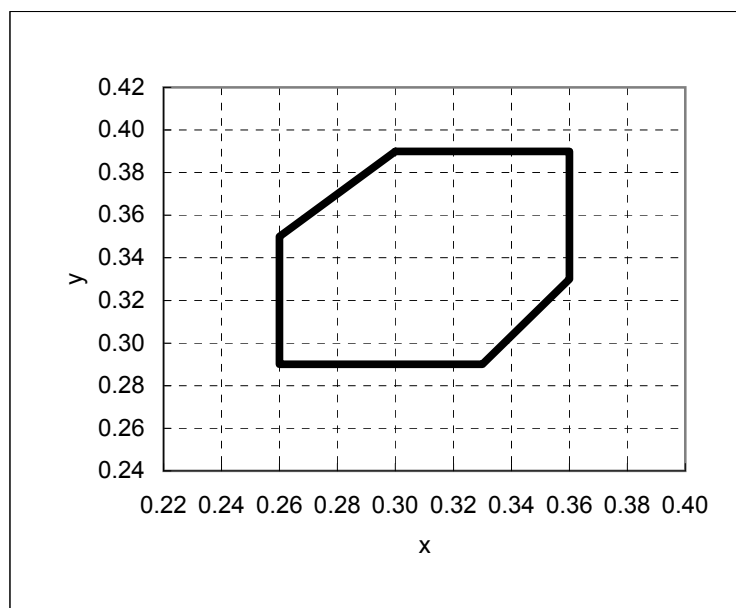

White Chromaticity Range

【White Chromaticity Range】

x	y
0.30	0.39
0.26	0.35
0.26	0.29
0.33	0.29
0.36	0.33
0.36	0.39

15.2 Temperature Characteristics

< Measurement Condition >

Measuring instruments: CS1000 (KONICA MINOLTA) , LCD7200(OTSUKA ELECTRONICS)

Driving condition: VDD = 3.0V, VSS = 0V

Optimized VCOMDC

Backlight: IL=7.0mA

Item		Specification		Remark	
		Ta=-20°C	Ta=70°C		
Contrast ratio	CR	200 or more	200 or more	Backlight ON	
Response time	Rise time	TON	600 msec or less	50 msec or less	
	Fall time	TOFF	400 msec or less	30 msec or less	
Display Quality		No noticeable display defect or nonuniformity should be observed.			

16. Criteria of Judgment

16.1 Defective Display and Screen Quality

Test Condition: Observed TFT-LCD monitor from front during operation
with the following conditions

Driving Signal Raster Pattern (RGB, white, black)

Signal condition [Data]: 00h, 28h, 3Fh (3steps)

Observation distance 30 cm

Illuminance 200 to 350 lx

Backlight IL=7.0mA

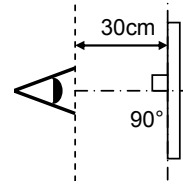

Defect item	Defect content		Criteria	
Display Quality	Line defect	Black, white or color line, 3 or more neighboring defective dots	Not exists	
	Dot defect	Uneven brightness on dot-by-dot base due to defective TFT or CF, or dust is counted as dot defect (brighter dot, darker dot) High bright dot: Visible through 2% ND filter at [Data]=00h Low bright dot: Visible through 5% ND filter at [Data]=00h Dark dot: Appear dark through white display at [Data]=28h Invisible through 5% ND filter at [Data]=00h	Refer to table 1 Acceptable	
		Dirt	Uneven brightness (white stain, black stain etc)	Invisible through 5% ND filter at Black screen. Invisible through 1% ND filter at other screen.
Screen Quality	Foreign particle	Point-like	$0.25\text{mm} < \varphi$ $0.20\text{mm} < \varphi \leq 0.25\text{mm}$ $\varphi \leq 0.20\text{mm}$	N=0 N ≤ 2 Acceptable
		Liner	$3.0\text{mm} < \text{length and } 0.08\text{mm} < \text{width}$ $\text{length} \leq 3.0\text{mm or width} \leq 0.08\text{mm}$	N=0 Acceptable
			Flaw	Flaw on the surface of the Touch panel
		$2 < L \leq 5\text{mm}$ $L \leq 2\text{mm}$		N ≤ 5 Acceptable
		Others		

φ (mm): Average diameter = (major axis + minor axis)/2

Permissible number: N

Table 1

Area	High bright dot	Low bright dot	Dark dot	Total	Criteria
A	0	2	2	3	Permissible distance between same color bright dots (includes neighboring dots): 3 mm or more
B	2	4	4	5	Permissible distance between same color high bright dots (includes neighboring dots): 5 mm or more
Total	2	4	4	5	

<Portrait model>

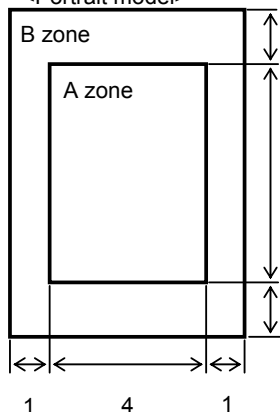

Division of A and B areas

B area: Active area

Dimensional ratio between A and B areas: 1: 4: 1 (Refer to the left figure)

16.2 Screen and Other Appearance

Testing conditions

Observation distance	30cm
Illuminance	1200~2000 lx

Item	Criteria	Remark
Polarizer Flaw Stain Bubble Dust Dent	Ignore invisible defect when the backlight is on.	Applicable area: Active area only (Refer to the section 3.2 "Outward form")
S-case	No functional defect occurs	
FPC cable	No functional defect occurs	

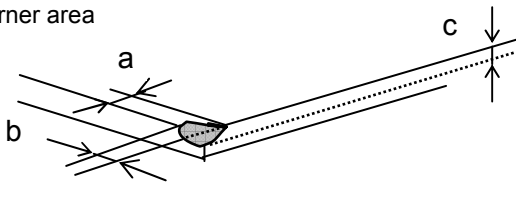
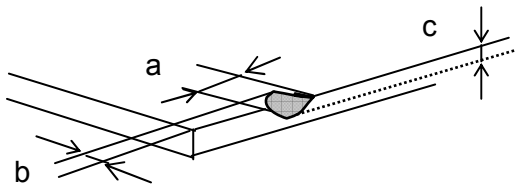
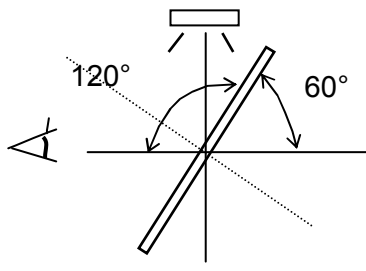
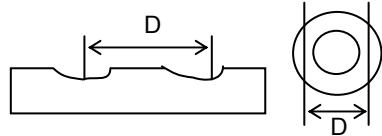
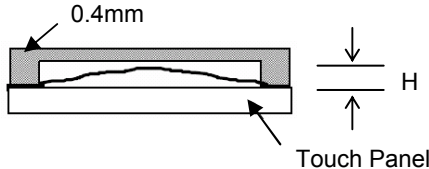
Item	Appearance	Criteria
Touch Panel	Corner area 	Unit:mm $a \leq 3$ $b \leq 3$ $c \leq t$ (t: glass thickness) $a, b \leq 0.5$ is acceptable. $n \leq 2$
	Others 	Unit:mm $a \leq 5$ $b \leq 1$ $c \leq t$ (t:glass thickness) $a, b \leq 0.5$ is acceptable Maximum permissible number of chipping off on a side is 5.
	Progressive crack	None
	Concentric interference fringe (Test method) Observe the Panel surface from 60 degrees angle to the surface under white fluorescent lamp (Triple band fluorescent lamp) 	Average diameter : $D \leq 8\text{mm}$ is acceptable. Darkness: comply with the boundary sample
	Fisheye Film surface 	$D \leq \phi 0.2\text{mm}$ Acceptable $\phi 0.2 < D \leq \phi 0.6\text{mm}$ $N \leq 2$ $\phi 0.6\text{mm} < D$ $N = 0$
Puffiness 	$H \leq 0.4\text{mm}$ is acceptable.	

17. Reliability Test

Test item		Test condition		number of failures /number of examinations
Durability test	High temperature storage	Ta=80° C	240hr	0 / 3
	Low temperature storage	Ta=-30° C	240hr	0 / 3
	High temperature & high humidity storage	Ta=60° C, RH=90% non condensing	240hr	0 / 3
	High temperature operation	Tp=70° C	240hr	0 / 3
	Low temperature operation	Tp=-20° C	240hr	0 / 3
	High temp & humid operation	Tp=40° C, RH=90% non condensing	240hr	0 / 3
	Thermal shock storage	-30←→80° C(30min/30min)	100 cycles	0 / 3
Mechanical environmental test	Electrostatic discharge test (Non operation)	Confirms to EIAJ ED-4701/300 C=200pF,R=0Ω,V=±200V Each 3 times of discharge on and power supply and other terminals.		0 / 3
	Surface discharge test (Non operation)	C=250pF, R=100Ω, V=±12kV Each 5 times of discharge in both polarities on the center of screen with the case grounded.		0 / 3
	Vibration test	Total amplitude 1.5mm, f=10~55Hz, X,Y,Z directions for each 2 hours		0 / 3
	Impact test	Use ORTUS TECHNOLOGY original jig (see next page)and make an impact with peak acceleration of 1000m/s ² for 6 msec with half sine-curve at 3 times to each X, Y, Z directions in conformance with JIS C 60068-2-27-2011.		0 / 3
Packing test	Packing vibration-proof test	Acceleration of 19.6m/s ² with frequency of 10→55→10Hz, X,Y, Zdirection for each 30 minutes		0 / 1 packing
	Packing drop test	Drop from 75cm high. 1 time to each 6 surfaces, 3 edges, 1 corner		0 / 1 packing

Note: Ta=ambient temperature Tp=Panel temperature

※ The profile of high temperature/humidity storage and High Temperature/humidity operation (Pure water of over 10MΩ·cm shall be used.)

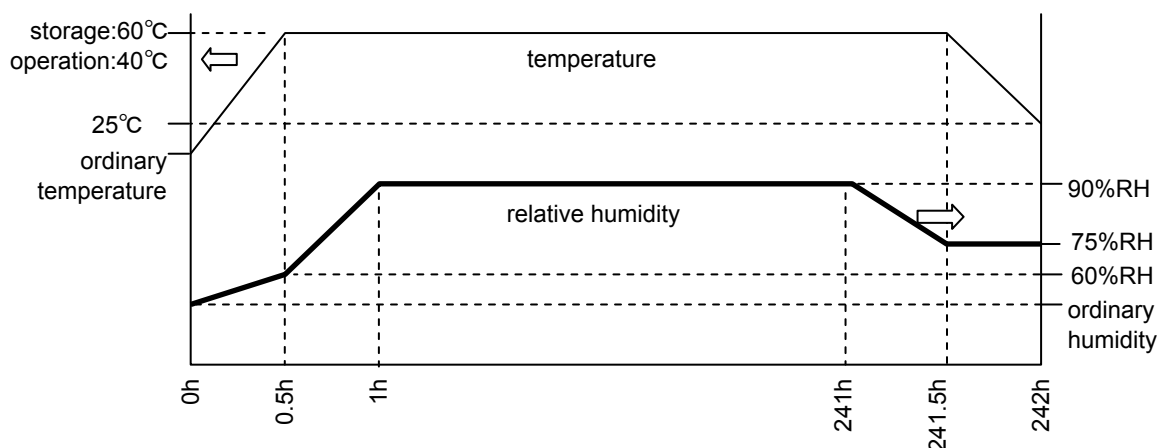
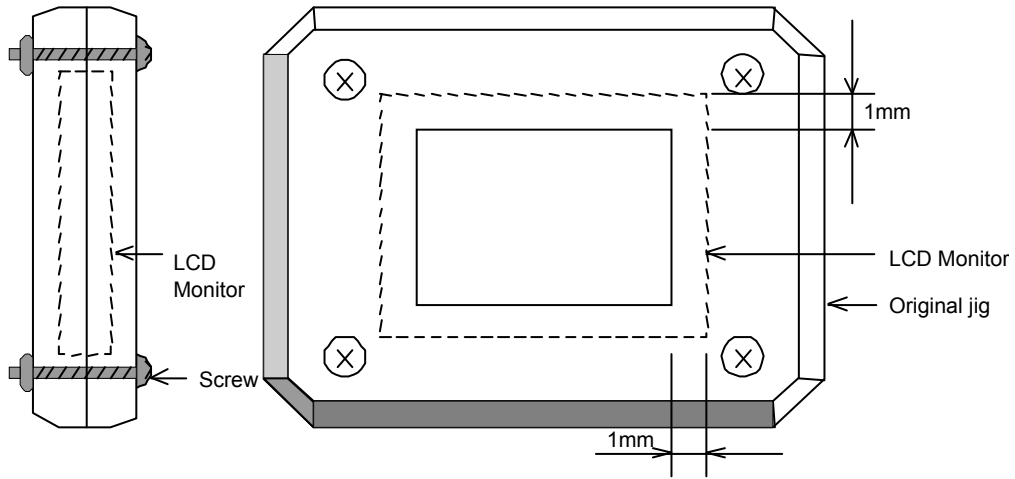

Table2.Reliability Criteria

The parameters should be measured after leaving the monitor at the ordinary temperature for 24 hours or more after the test completion.

item	Standard	Remarks
Display quality	No visible abnormality shall be seen. (Except for unevenness by Pol deterioration.)	
Contrast ratio	200 or more	Backlight ON

ORTUS TECHNOLOGY Original Jig



18. Packing Specifications

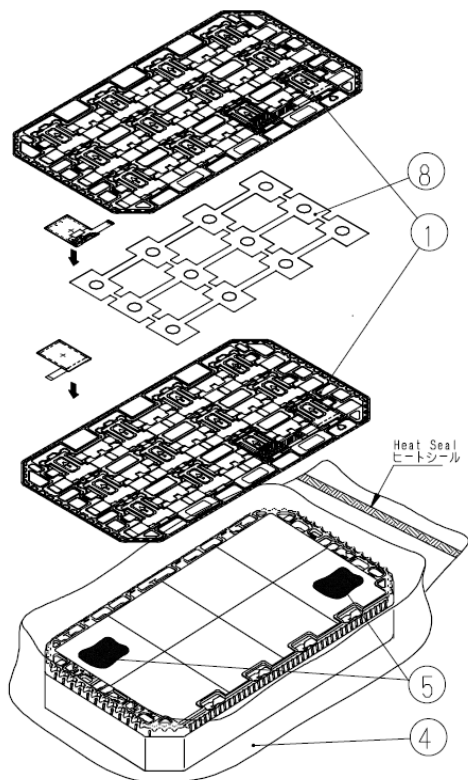

Step 1. Each product is to be placed in one of the cut-outs of the tray with the display surface facing upward.
 Foam sheet A are to be placed on the products in the tray.
 Each product is to be placed in one of the cut-outs of the tray with the display surface facing downward.(24products per tray)

Step 2. Each tray is to be piled up in same orientation and the trays be in a stack of 6.
 One empty tray is to be put on the top of stack of 6 trays.

Step 3. 2 packs of moisture absorbers are to be placed on the top tray as shown in the drawing.
 Put piled trays into a sealing bag.

Step 4. Vacuum and seal the sealing bag with the vacuum sealing machine.

Step 5. The stack of trays in the plastic back is to be wrapped with B SHEET A.

Step 6. The wrapped trays are placed in the carton.

Step 7. B SHEET B are to be inserted into a outer carton with same orientation. The outer carton is to be sealed in H-shape with packing tape as shown in the drawing.

Step 8. The model number, quantity of products, and shipping date are to be printed on the outer carton.
 If necessary, shipping labels or impression markings are to be put on the outer carton.

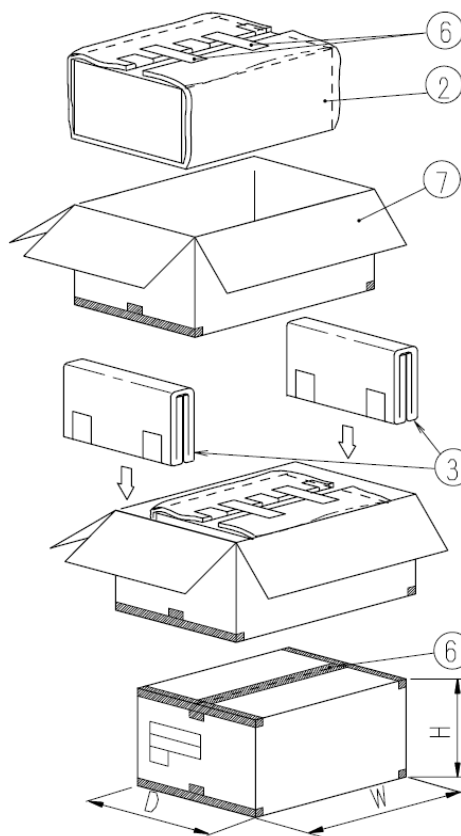

Remark: The return of packing materials is not required.

	Packing item name	Specs., Material
①	Tray	A-PET
②	B SHEET A	Anti-static air babble sheet
③	B SHEET B	Anti-static air babble sheet
④	Sealing bag	
⑤	Drier	Moisture absorber
⑥	Packing tape	
⑦	Outer carton	Corrugated cardboard
⑧	FOAM SHEET A	Anti-static polyethilene

Dimension of outer carton	
D : Approx.	(337mm)
W : Approx.	(618mm)
H : Approx.	(179mm)
Quantity of products packed in one carton:	144
Gross weight : Approx.	6.0 Kg

19. Handling Instruction

19.1 Cautions for Handling LCD panels

**Caution**

- (1) Do not make an impact on the LCD panel glass because it may break and you may get injured from it.
- (2) If the glass breaks, do not touch it with bare hands.
(Fragment of broken glass may stick you or you cut yourself on it.)
- (3) If you get injured, receive adequate first aid and consult a medial doctor.
- (4) Do not let liquid crystal get into your mouth.
(If the LCD panel glass breaks, try not let liquid crystal get into your mouth even toxic property of liquid crystal has not been confirmed.)
- (5) If liquid crystal adheres, rinse it out thoroughly.
(If liquid crystal adheres to your cloth or skin, wipe it off with rubbing alcohol or wash it thoroughly with soap. If liquid crystal gets into eyes, rinse it with clean water for at least 15 minutes and consult an eye doctor.)
- (6) If you scrap this products, follow a disposal standard of industrial waste that is legally valid in the community, country or territory where you reside.
- (7) Do not connect or disconnect this product while its application products is powered on.
- (8) Do not attempt to disassemble or modify this product as it is precision component.
- (9) If a part of soldering part has been exposed, and avoid contact (short-circuit) with a metallic part of the case etc. about FPC of this model, please.
Please insulate it with the insulating tape etc. if necessary.
The defective operation is caused, and there is a possibility to generation of heat and the ignition.
- (10) Since excess current protection circuit is not built in this TFT module, there is the possibility that LCD module or peripheral circuit become feverish and burned in case abnormal operation is generated.
We recommend you to add excess current protection circuit to power supply.
- (11) The end part of glass and film of touch panel has conductivity, and avoid contact (short-circuit) with electroconductive case etc.. There is a possibility of setting up a defective touch panel, and insulate it for the case suppression (cushion etc.) if necessary, please.
- (12) The devices on the FPC are damageable to electrostatic discharge, because the terminals of the devices are exposed.
Wear grounded wrist-straps and use electrostatic neutralization blowers to prevent static charge and discharge when handling the TFT monitors.
Designate an appropriate operating area, and set equipment, tools, and machines properly when handling this product.

**Caution**

This mark is used to indicate a precaution or an instruction which, if not correctly observed, may result in bodily injury, or material damages alone.

19.2 Precautions for Handling

- 1) Wear finger tips at incoming inspection and for handling the TFT monitors to keep display quality and keep the working area clean.
Do not touch the surface of the monitor as it is easily scratched.
- 2) Wear grounded wrist-straps and use electrostatic neutralization blowers to prevent static charge and discharge when handling the TFT monitors as the LED in this TFT monitors is damageable to electrostatic discharge. Designate an appropriate operating area, and set equipment, tools, and machines properly when handling this product.
- 3) Avoid strong mechanical shock including knocking, hitting or dropping to the TFT monitors for protecting their glass parts. Do not use the TFT monitors that have been experienced dropping or strong mechanical shock.
- 4) Do not use or storage the TFT monitors at high temperature and high humidity environment. Particularly, never use or storage the TFT monitors at a location where condensation builds up.
- 5) Avoid using and storing TFT monitors at a location where they are exposed to direct sunlight or ultraviolet rays to prevent the LCD panels from deterioration by ultraviolet rays.
- 6) Do not stain or damage the contacts of the FPC cable .
FPC cable needs to be inserted until it can reach to the end of connector slot.
During insertion, make sure to keep the cable in a horizontal position to avoid an oblique insertion.
Otherwise, it may cause poor contact or deteriorate reliability of the FPC cable.
- 7) Do not bend or pull the FPC cable or carry the TFT monitor by holding the FPC cable.
- 8) Peel off the protective film on the TFT monitors during mounting process.
Refer to the section 19.5 on how to peel off the protective film.
We are not responsible for electrostatic discharge failures or other defects occur when peeling off the protective film.

19.3 Precautions for Operation

- 1) Since this TFT monitors are not equipped with light shielding for the driver IC, do not expose the driver IC to strong lights during operation as it may cause functional failures.
- 2) In case of powering up or powering off this LCD module, be sure to comply the sequence as instructed in this specification.
- 3) Do not plug in or out the FPC cable while power supply is switch on.
Plug the FPC cable in and out while power supply is switched off.
- 4) Do not operate the TFT monitors in the strong magnetic field. It may break the TFT monitors.
- 5) Do not display a fixed image on the screen for a long time.
Use a screen-saver or other measures to avoid a fixed image displayed on the screen for a long time.
Otherwise, it may cause burn-in image on the screen due the characteristics of liquid crystal.

19.4 Storage Condition for Shipping Cartons

Storage environment

- Temperature 0 to 40° C
- Humidity 60%RH or less
No-condensing occurs under low temperature with high humidity condition.
- Atmosphere No poisonous gas that can erode electronic components and/or wiring materials should be detected.
- Time period 1 year
- Unpacking To prevent damages caused by static electricity, anti-static precautionary measures (e.g. earthing, anti-static mat) should be implemented.
After unpack, keep product in the appropriate condition, otherwise bubble seal of Protective film may be printed on Polarizer.
- Maximum piling up 7 cartons

*Conditions to storage after unpacking

Storage environment

- Temperature 0 to 40° C
- Humidity 60%RH or less
No-condensing occurs under low temperature with high humidity condition.
- Atmosphere No poisonous gas that can erode electronic components and/or wiring materials should be detected.
- Time period 1 year (Shelf life)
- Others Keep/ store away from direct sunlight
Storage goods on original tray made by ORTUS.

19.5 Precautions for Peeling off the Protective film

The followings work environment and work method are recommended to prevent the TFT monitors from static damage or adhesion of dust when peeling off the protective films.

A) Work Environment

- a) Humidity: 50 to 70 %RH, Temperature 15 to 27 °C
- b) Operators should wear conductive shoes, conductive clothes, conductive finger tips and grounded wrist-straps.
Use an electrostatic neutralization blower.
Anti-static treatment should be implemented to work area's floor.
- c) Use a room shielded against outside dust with sticky floor mat laid at the entrance to eliminate dirt.

B) Work Method

The following procedures should taken to prevent the driver ICs from charging and discharging.

- a) Use an electrostatic neutralization blower to blow air on the TFT monitors to its lower left FPC is placed at the left.
Optimize direction of the blowing air and the distance between the TFT monitors and the electrostatic neutralization blower.
- b) Peel off the tab slowly (spending more than 2 secs to complete)
by pulling it to opposite direction.

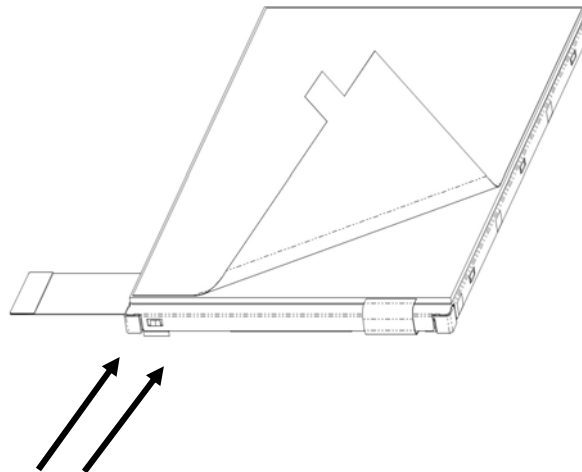

Direction of blowing air
(Optimize air direction and the distance)

19.6 Warranty

ORTUS is only liable to defective goods which is stored and used under the condition complying with this specifications and returned within 1 (one) year.

Warranty caused by manufacturing defect shall be conducted by replacement of goods or refundment at unit price.

APPENDIX

Reference Method for Measuring Optical Characteristics and Performance

1. Measurement Condition (Backlight ON)

Measuring instruments: CS1000 (KONICA MINOLTA) , LCD7200(OTSUKA ELECTRONICS) ,EZcontrast160D (ELDIM)

Driving condition: Refer to the section "Optical Characteristics"

Measured temperature: 25° C unless specified

Measurement system: See the chart below.

The luminance meter is placed on the normal line of measurement system.

Measurement point: At the center of the screen unless otherwise specified

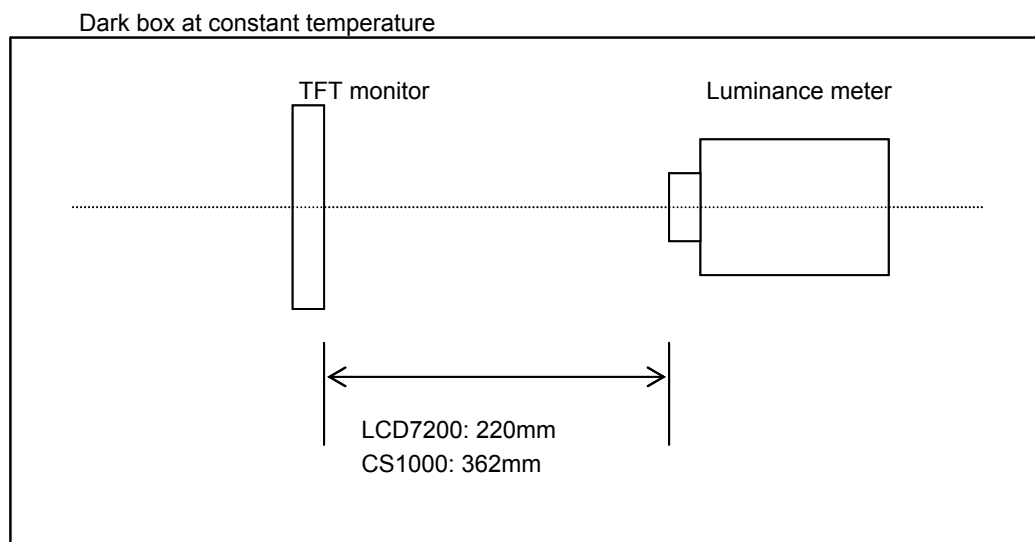

Measurement is made after 30 minutes of lighting of the backlight.

Measurement point: At the center point of the screen

Brightness distribution: 9 points shown in the following drawing.

<Portrait model>

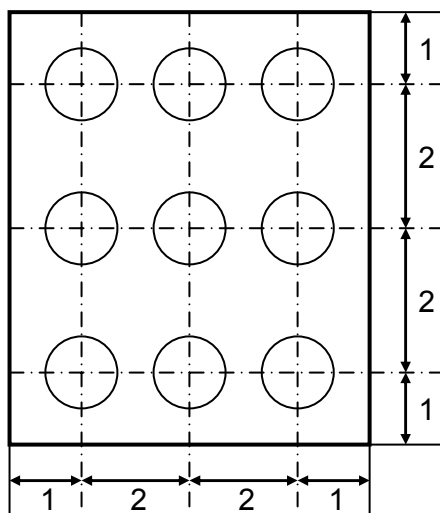

Dimensional ratio of active area

Backlight IL=7.0mA

Measurement Condition (Contrast ratio Backlight OFF only)

Measuring instruments: LCD7200(OTSUKA ELECTRONICS),Ring Light(40,000 lx, ϕ 58)

Driving condition: Refer to the section "Optical Characteristics"

Measured temperature: 25° C unless specified

Measurement system: See the chart below.

Measurement point: At the center of the screen.

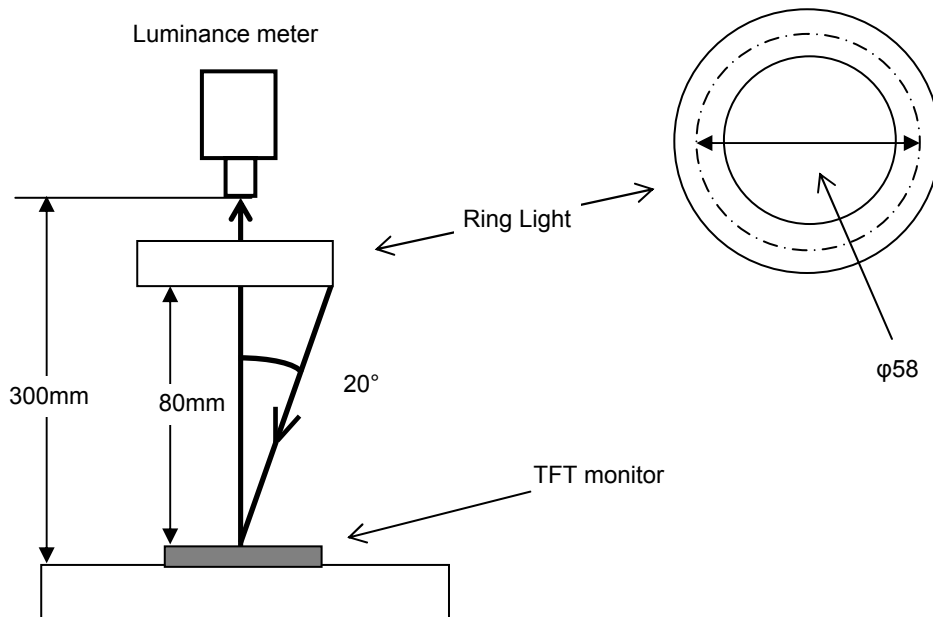

* Linearity Measurement of Touch Panel

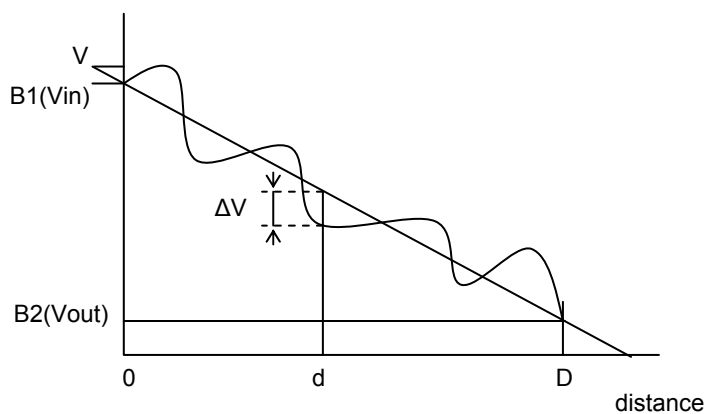

$$LE(\%) = \Delta V / (V_{in} - V_{out}) \times 100$$

$$LE_{max}(\%) = \Delta V_{max} / (V_{in} - V_{out}) \times 100$$

■ Cautionary instruction to handle a Touch-panel

● Cushion (between Touch Panel Chassis) Design

1) A cushion is required to be placed between Touch Panel and customer's chassis and there is a designated area to attach it. Attachment at area inside Input Prohibition Area must be forbidden.

If cushion was located inside Input Prohibition Area, Upper Electrode may be push constantly and which may cause the electrode breakage at the position falling on the edge of adhesive; it eventually results in Touch Panel malfunction in the future. (Please see "NG-1")

2) Be attention to the cushion material you use. In the case that too soft cushion was used, the cushion may protrude into Prohibition Area by being push strongly; which may result in the electrode breakage. Eventually there is a chance that the electrode breakage leads to the malfunction of Touch Panel in the future. (Please see "NG-2")

3) Cushion is required to be attached at the side of Customer's chassis. Attaching a cushion at the side of Upper Electrode Film has a chance to deform the film and lead to the malfunction of Touch Panel in the future.

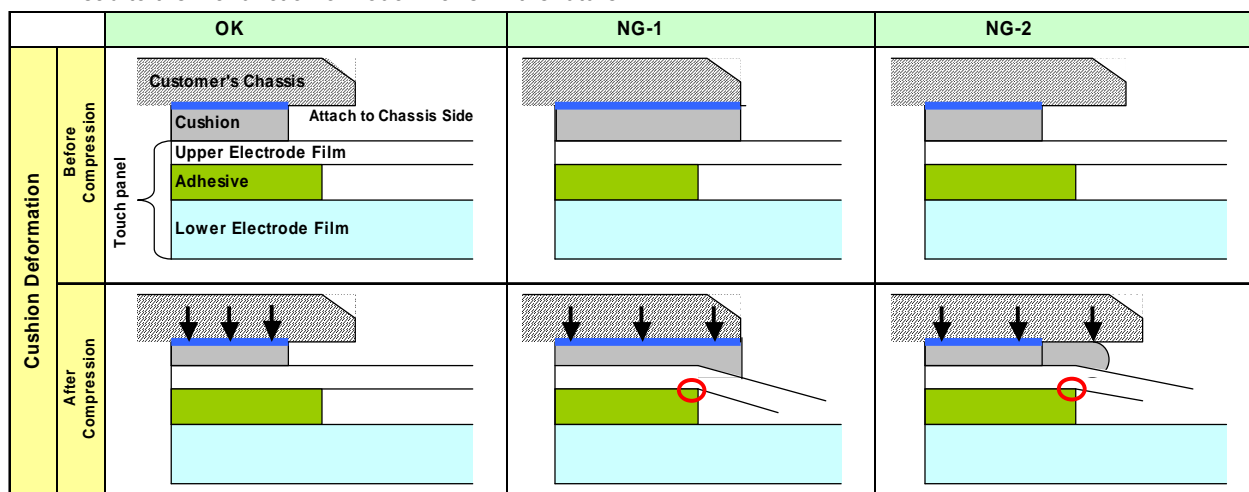

● Design Guidance of Chassis (Front Part)

4) Be attention to stay Input Prohibition Area away from touching and/or drawing by a stylus pens in order to avoid the electrode breakage and potential malfunction of Touch Panel. (Please see "NG-3")
We recommend customers to design chassis (front case) being able to protect Input Prohibition Area.

5) Clearance between customer's chassis and Touch Panel surface is certainly required in order to avoid erroneous input caused by a collision of the edge of chassis. (Please see "NG-4")
A clearance of 0.3 to 0.7mm is recommended.

● Design Guidance of Chassis (Side Part)

6) Upper Electrode and Lower Electrode fall on the edge of Touch Panel outline.
Redundant design having enough clearance to avoid electric short with chassis is highly recommended. (Please see "NG-5")

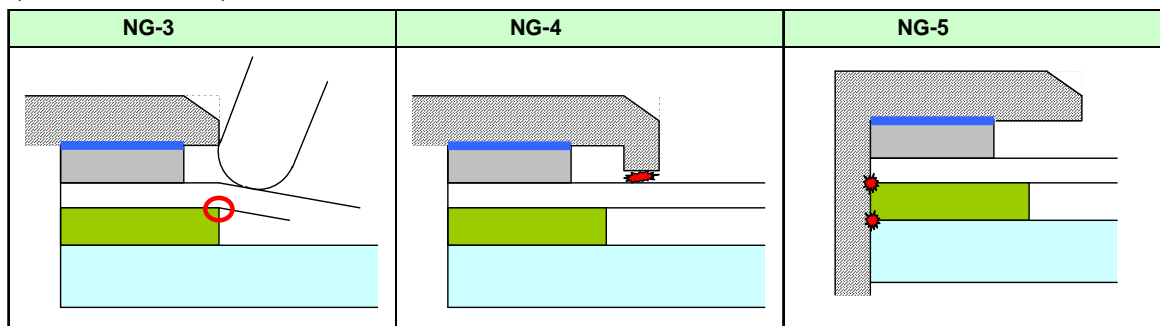

● Example of Recommended Chassis Design

Refer to "3.2 Outward Form".

● As a terminal resistance has individual specificity, calibration to align the displaying and the sensing position one each is mandatory before use.

2. Test Method

Notice	Item	Test method	Measuring instrument	Remark
1	Response time	<p>Measure output signal waves with a brightness meter when the raster or window pattern is changed over from Black to White and from White to Black</p> <p style="text-align: center;">Black White Black</p> <p>White brightness</p> <p>100%</p> <p>90%</p> <p>10%</p> <p>0%</p> <p>Black brightness</p> <p style="text-align: center;">← TON TOFF →</p>	LCD7200	<p>Black display [Data]=00h</p> <p>White display [Data]=3Fh</p> <p>TON</p> <p>Rise time</p> <p>TOFF</p> <p>Fall time</p>
2	Contrast ratio	<p>Measure maximum luminance Y1([Data]=3Fh) and minimum luminance Y2([Data]=00h) at the center of the screen by displaying raster or window pattern. Then calculate the ratio between these two values.</p> <p style="text-align: center;">Contrast ratio = Y1/Y2</p> <p style="text-align: center;">Diameter of measuring point: 8mmφ(CS1000)</p> <p style="text-align: center;">Diameter of measuring point: 3mmφ(LCD7200)</p>	CS1000 LCD7200	Backlight ON Backlight OFF
3	Viewing angle Horizontalθ Verticalφ	Move the luminance meter from right to left and up and down and determine the angles where contrast ratio is 10.	EZcontrast160D	
4	White chromaticity	<p>Measure chromaticity coordinates x and y of CIE1931 colorimetric system at [Data] = 3Fh</p> <p style="text-align: center;">Color matching function: 2°view</p>	CS1000	
5	Burn-in	Visually check burn-in image on the screen after 2 hours of "window display" ([Data]=00h/3Fh).	At optimized VCOMDC	
6	Center brightness	Measure the brightness at the center of the screen.	CS1000	
7	Brightness distribution	<p>(Brightness distribution) = 100 x B/A %</p> <p>A : max. brightness of the 9 points</p> <p>B : min. brightness of the 9 points</p>	CS1000	

Version History

Ver.	Date	Page	Description
1.0	May. 12, 2016	-	- First issue

Our company network supports you worldwide with offices in Germany, Austria, Switzerland, Great Britain and the USA. For more information please contact:

Headquarters

Germany



FORTEC Elektronik AG

Lechwiesenstr. 9
86899 Landsberg am Lech

Phone: +49 8191 91172-0
E-Mail: sales@forteca.de
Internet: www.forteca.de

Fortec Group Members

Austria



FORTEC Elektronik AG

Office Vienna

Nuschinggasse 12
1230 Wien

Phone: +43 1 8673492-0
E-Mail: office@fortec.at
Internet: www.fortec.at

Germany



Distec GmbH

Augsburger Str. 2b
82110 Germering

Phone: +49 89 894363-0
E-Mail: info@distec.de
Internet: www.distec.de

Switzerland



ALTRAC AG

Bahnhofstraße 3
5436 Würenlos

Phone: +41 44 7446111
E-Mail: info@altrac.ch
Internet: www.altrac.ch

United Kingdom



Display Technology Ltd.

5 The Oaks Business Village
Revenge Road, Lordswood
Chatham, Kent, ME5 8LF

Phone: +44 1634 62755
E-Mail: info@displaytechnology.co.uk
Internet: www.displaytechnology.co.uk

USA



Apollo Display Technologies, Corp.

87 Raynor Avenue,
Unit 1 Ronkonkoma,
NY 11779

Phone: +1 631 5804360
E-Mail: info@apolloDisplays.com
Internet: www.apolloDisplays.com