



OUR GLOBAL
COMPETENCE
CENTRES

 APOLLO DISPLAY
TECHNOLOGIES



 DISTEC



 DISPLAY
TECHNOLOGY



Datasheet

Tianma

P1210XGF1MA01

TI-01-014

SPECIFICATION

Preliminary Specification

Final Specification

Description **12.1” 1024x768 TFT-LCD Module**
Part Number **P1210XGF1MA01**

Customer	Industrial Product Dept, PDBU Tianma Microelectronics Co., Ltd.		
Signatures	Date	Approved By	Date
_____	_____	XiaoXing Ding	2022/2/7
_____	_____	Reviewed By	
		Longping Deng	2022/2/7
		Prepared By	
		Chunhui Yang	2022/2/7
Comments:			

* This cover page is for your Comments and Signatures back to TIANMA.

REVISION HISTORY

Rev	Date	Page	Revision Items	Editor
1.0	2020/09/29		Preliminary Specification release.	Chunhui.Yang
2.0	2022/02/13		Final Specification release.	Bin.Wang
2.1	2023/02/08		Update 3.1 mode select & 5.1 Inrush current & Mechanical Drawing	Bin.Wang

CONTENTS

1. SUMMARY	1
1.1 General Description	1
1.2 Features	1
2. GENERAL SPECIFICATIONS	2
3. INPUT / OUTPUT TERMINALS	3
3.1 CN1 Pin assignment (LCD Interface).....	3
3.2 CN2 Pin assignment (Back Light).....	4
4. ABSOLUTE MAXIMUM RATINGS	5
5. ELECTRICAL CHARACTERISTICS.....	6
5.1 DC Characteristics for Panel Driving	6
5.2 DC Characteristics for Backlight Driving	7
5.3 Recommended Power ON/OFF Sequence	7
5.4 LCD Module Block Diagram.....	8
6. TIMING CHARACTERISTICS.....	9
6.1 LVDS interface AC characteristics	9
6.2 Data Input Timing Parameter Setting	10
6.3 LVDS interface Timing characteristics	10
6.4 LVDS input Timing format	11
7. OPTICAL CHARACTERISTICS.....	12
8. RELIABILITY TEST	15
9. MECHANICAL DRAWING	16
10. PACKING INSTRUCTION	17
11. PRECAUTIONS FOR USE OF LCD MODULES	18
11.1 Handling Precautions	18
11.2 Storage precautions	18
11.3 Transportation Precautions	18
11.4 Screen saver Precautions	18
11.5 Safety Precautions	18

1. Summary

1.1 General Description

This is a 12.1 inch a-Si TFT-LCD module with Normal- Black technology. It is composed of a TFT-LCD panel, a driver circuit, FPC, PCB, Bezel, and a LED backlight unit.

1.2 Features

- Ultra-wide viewing angle.
- High luminance.
- Long LED life time.
- Wide temperature range.
- Interface: LVDS 6/8 bits.

- Acquisition product for UL62368-1/CSA C22.2 No.62368 -1-14.
- Compliant with the European RoHS Directive (2011/65/EU) and Delegated Directive (2015/863/EU, Amending Annex II of 2011/65/EU).

2. General Specifications

	Feature	Spec	Unit
Display Spec	Size	12.1 inches	
	Resolution	1024x768	
	Pixel Pitch	0.240 (H) x 0.240 (V)	mm
	TFT Active Area	245.76 x 184.32	mm
	Technology Type	a-Si	
	Pixel Configuration	R.G.B Vertical Stripe	
	Display Mode	SFT, Normally Black	
	Surface Treatment	Anti-Glare	
	Viewing Direction	All Direction	
Mechanical Characteristics	LCM (W x H x D)	260.5x203x9.5	mm
	Weight	550	g
Optical Characteristics	Luminance	Typ:800	cd/m2
	Contrast Ratio	Typ:1000:1	
	NTSC	Typ:72	%
	Viewing Angle	88/88/88/88(SFT)	degree
Electrical Characteristics	Interface	LVDS 6/8 bits	
	Color Depth	16.7 Million color/262 Kilo color	color
	Power Consumption	LCD:561; Backlight:7800	mW

Table 2.1 General TFT Specifications

3. Input / Output Terminals

3.1 CN1 Pin assignment (LCD Interface)

Connector Information	
Connector type	FI-SEB20P-HFE(JAE)
Matching connector	FI-S20S, FI-SE20-ME(JAE)

Table 3.1.1 Connector information

Pin No.	Symbol	I/O	Function	Remark
1	Vcc	P	3.3V power supply	
2	Vcc	P	3.3V power supply	
3	GND	P	Ground	
4	GND	P	Ground	
5	D0-	I	Negative LVDS differential data input	
6	D0+	I	Positive LVDS differential data input	
7	GND	P	Ground	
8	D1-	I	Negative LVDS differential data input	
9	D1+	I	Positive LVDS differential data input	
10	GND	P	Ground	
11	D2-	I	Negative LVDS differential data input	
12	D2+	I	Positive LVDS differential data input	
13	GND	P	Ground	
14	CLK-	I	Negative LVDS differential clk input	
15	CLK+	I	Positive LVDS differential clk input	
16	GND	P	Ground	
17	D3-	I	Negative LVDS differential data input	
18	D3+	I	Positive LVDS differential data input	
19	MODE	I	6-bit / 8-bit input select for LVDS interface. High or Open: 8bit Low: 6bit.	Default H
20	SC	I	Scan direction control (High or Open: Normal Low: Reverse)	Default H

Table 3.1.2 Pin Assignment for LCD Interface

Note1: I---Input, O---Output, P--- Power/Ground

Note2: All of the GND Pins should be connected to the system ground.

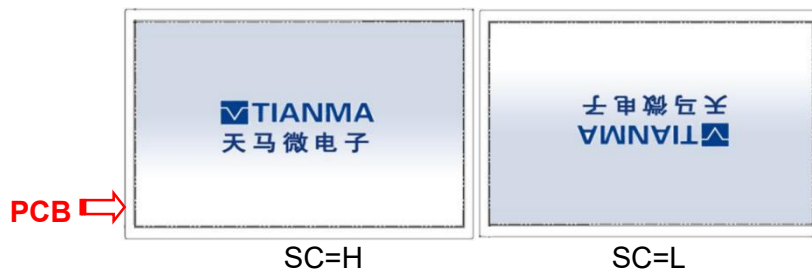

3.2 CN2 Pin assignment (Back Light)

Connector Information	
Connector type	SM10B-SHLS-TF(LF)(SN)(JST)
Matching connector	SHLP-10V-S-B(JST)

Table 3.2.1 Connector information

Pin	Symbol	I/O	Description	Remark
1	Vi	P	Converter input voltage	
2	Vi	P	Converter input voltage	
3	Vi	P	Converter input voltage	
4	Vi	P	Converter input voltage	
5	V _{GND}	P	Converter ground	
6	V _{GND}	P	Converter ground	
7	V _{GND}	P	Converter ground	
8	V _{GND}	P	Converter ground	
9	EN	I	Enable pin	Default High High: Backlight ON Low: Backlight OFF
10	PWM	I	Backlight Adjust	Default High High: 100% Luminance

Table 3.2.2 Pin Assignment for Back Light Interface

I/O definition:

I----Input O----Output I/O----Input/Output P----Power/Ground N—No Connect

4. Absolute Maximum Ratings

Item	Symbol	MIN	MAX	Unit	Remark
Input voltage	V _{IN}	-0.3	5	V	Note1
	VLVDS	-0.3	5	V	Note2
Operating Temperature	Top	-30	80	°C	-
Storage Temperature	Tst	-40	90	°C	-
Relative Humidity Note2	RH	--	≤95	%	Ta≤40°C
		--	≤85	%	40°C < Ta≤50°C
		--	≤55	%	50°C < Ta≤60°C
		--	≤36	%	60°C < Ta≤70°C
		--	≤24	%	70°C < Ta≤80°C
Absolute Humidity	AH	--	≤70	g/m ³	Ta > 80°C

Table 4.1 Absolute Maximum Ratings

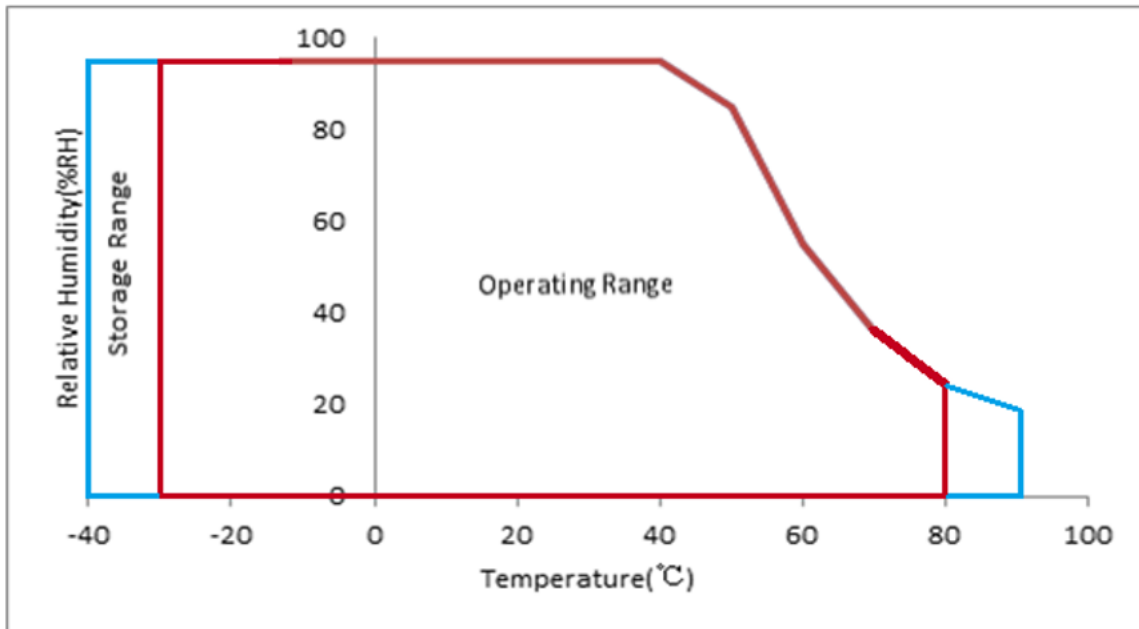

Table 4.2 Absolute Maximum Ratings chart

Note1: Input voltage include MODE,SC,VCC.

Note2: Including Link0+/-, Link1+/-, Link2+/-, Link3+/-,CLKIN+/-.

Note3:Ta means the ambient temperature. It is necessary to limit the relative humidity to the specified temperature range. Condensation on the module is not allowed.

Note4:The absolute maximum rating values of this product are not allowed to be exceeded at any times. A module should be used with any of the absolute maximum ratings exceeded, the characteristics of the module may not be recovered, or in an extreme condition, the module may be permanently destroyed

5. Electrical Characteristics

5.1 DC Characteristics for Panel Driving

VCC=3.3V,GND=0V, Ta=25°C

Item	Symbol	MIN	TYP	MAX	Unit	Remark
Power supply Voltage	VDD	3.2	3.3	3.4	V	
Power supply ripple	Vp-p	-	-	200	mV	
Power supply current	IDD	-	150	300	mA	Note1
LCD power consumption	P	-	495	990	mW	VDD=3.3V
Logic Input Voltage	Low level	VIL	0	-	0.3VDD	mV
	High level	ViH	0.7VDD	-	VDD	mV
Inrush current	Irush	-	-	1	A	Power on \geq 470us

Table 5.1.1 Operating Voltages

Note1: Typical picture is White.

5.2 DC Characteristics for Backlight Driving

Ta=25°C

Item	Symbol	Min	Typ	Max	Unit	Remark
LED driver input Voltage	Vi	11.2	12	12.8	V	
LED driver input Current	Ii	-	480	650	mA	
LED Part Power Consumption	WL	-	5760	7800	mW	Vi=12V
Input voltage for PWM signal	High level	E_PWM	1.2	-	3.3	V
	Low level		0	-	0.35	V
Input voltage for VLED_EN	ON Voltage	BLON	1.5	3.3	5	V
	OFF Voltage		0	-	0.8	V
VLED_PWM duty	D	5	-	100	%	
VLED_PWM frequency	Fpwm	200	-	10K	Hz	
LED Life Time	LT	--	70000	--	Hrs	

Table 5.2.1 LED Backlight Characteristics

Note 1: Optical performance should be evaluated at Ta=25°C Only.

Note 2: If LED is driven by high current, high ambient temperature & humidity condition, The life time of LED will be reduced.

Note 3: Operating life means brightness goes down to 50% of initial brightness. Typical operating life time is estimated data.

5.3 Recommended Power ON/OFF Sequence

5.3.1 LCD panel signal processing board

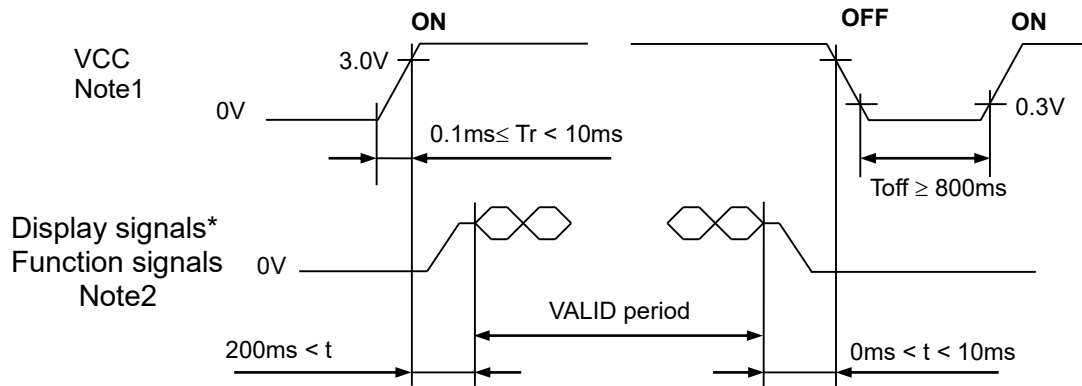

Figure 5.3.1 Power On/off sequence

* These signals should be measured at the terminal of 100Ω resistance.

Note1: If there is a voltage variation (voltage drop) at the rising edge of VCC below 3.0V, there is a possibility that a product does not work due to a protection circuit.

Note2: Display signals (D0+/-, D1+/-, D2+/- and CLK+/-) and function signals (DPS) must be set to Low or High-impedance, except the VALID period (See above sequence diagram), in order to avoid the circuitry damage.

If some of display and function signals of this product are cut while this product is working, even if the signal input to it once again, it might not work normally. If a customer stops the display and function signals, VCC also must be shut down.

5.3.2 LED Driver

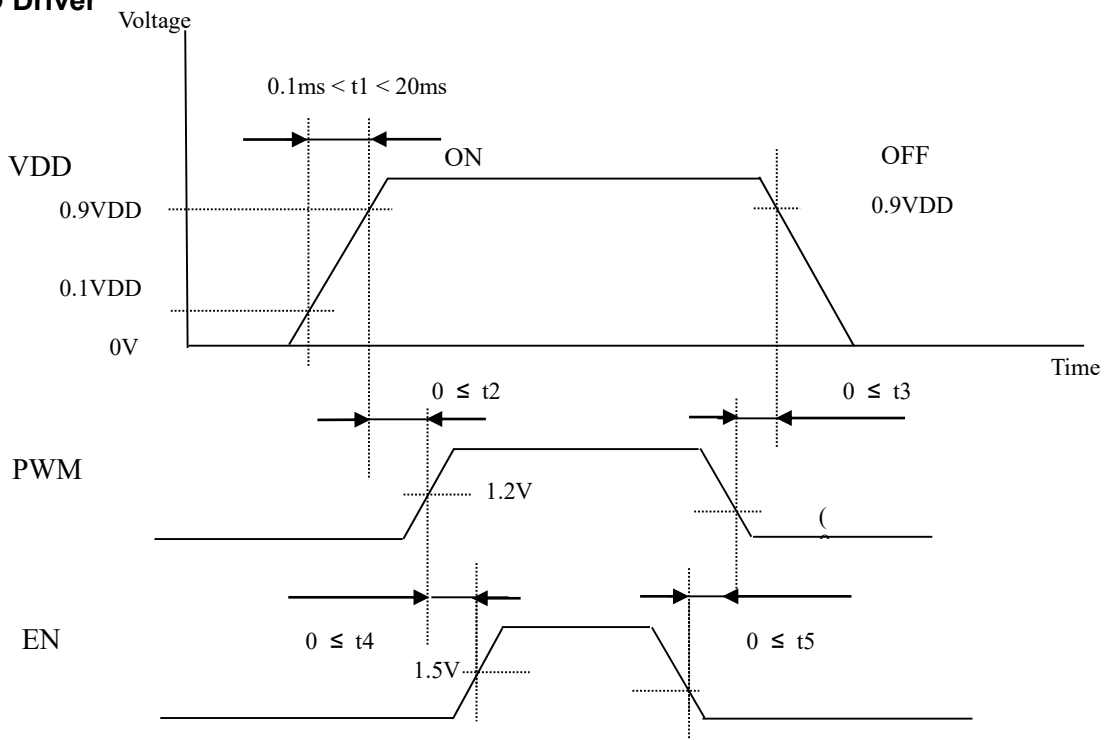

Figure 5.3.2 LED Power On/off sequence

5.4 LCD Module Block Diagram

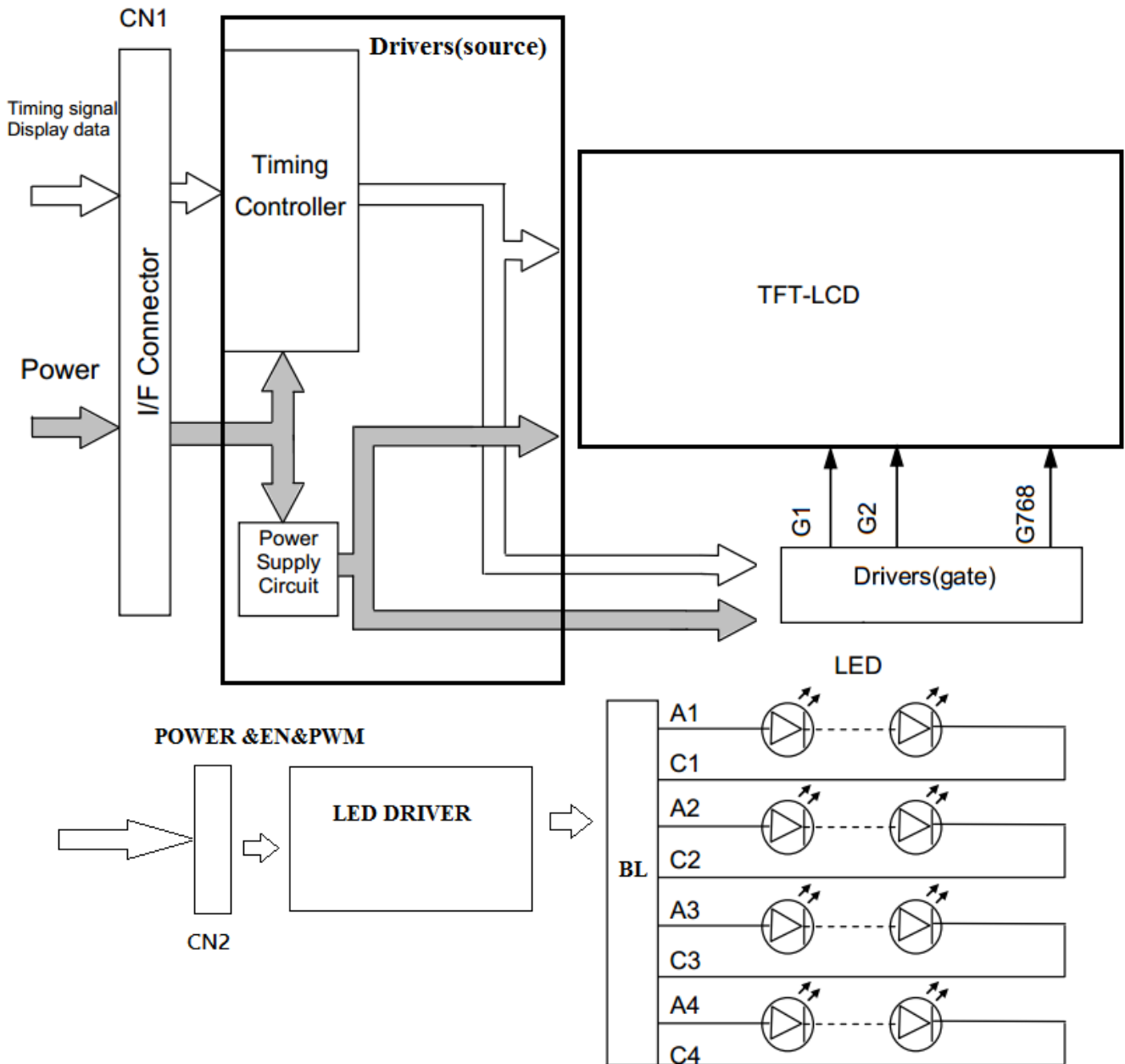

Figure 5.4.1 LCD Module Block Diagram

6. Timing Characteristics

6.1 LVDS interface AC characteristics

Parameter	Symbol	Min.	Typ.	Max.	Unit	Condition
Clock frequency	FLVCLK	25	-	85	MHz	Refer to input timing table for each display resolution.
Clock Period	TLVCLK	11.76	-	40	nsec	
Clock high time	TLVCH	-	$4/(7 * RXFCLK)$	-	ns	
Clock low time	TLVCL	-	$3/(7 * RXFCLK)$	-	ns	
Input data skew margin	TRSKM	-	-	0.25	UI	VCC_IF=1.8V w/o SSC
Strobe width	TSW	0.5	-	-	UI	
1 data bit time	UI	-	1/7	-	TLV CLK	
Position 1	TPOS1	-0.25	0	0.25	UI	
Position 0	TPOS0	0.75	1	1.25	UI	
Position 6	TPOS6	1.75	2	2.25	UI	
Position 5	TPOS5	2.75	3	3.25	UI	
Position 4	TPOS4	3.75	4	4.25	UI	
Position 3	TPOS3	4.75	5	5.25	UI	
Position 2	TPOS2	5.75	6	6.25	UI	

Table 6.1.1 LVDS interface AC characteristic

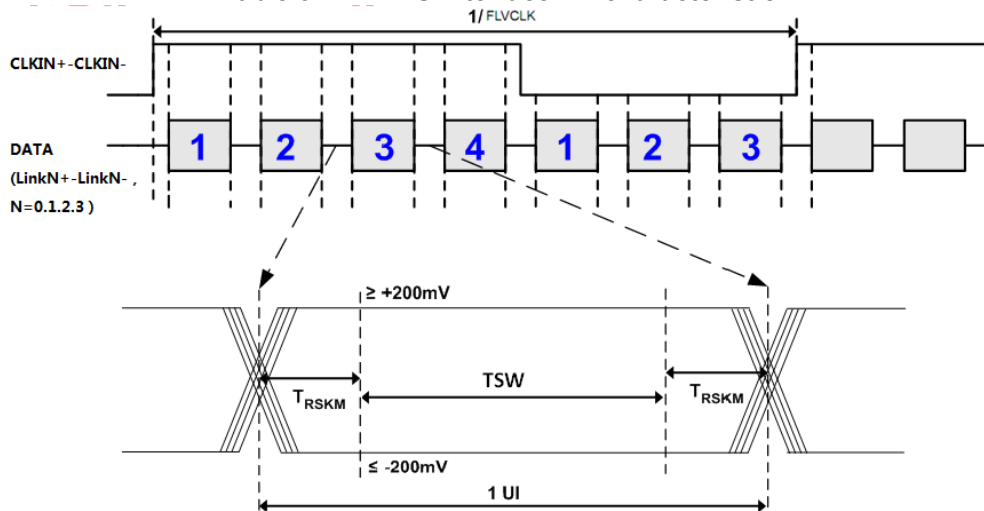

Table 6.1.2 LVDS Data Skew

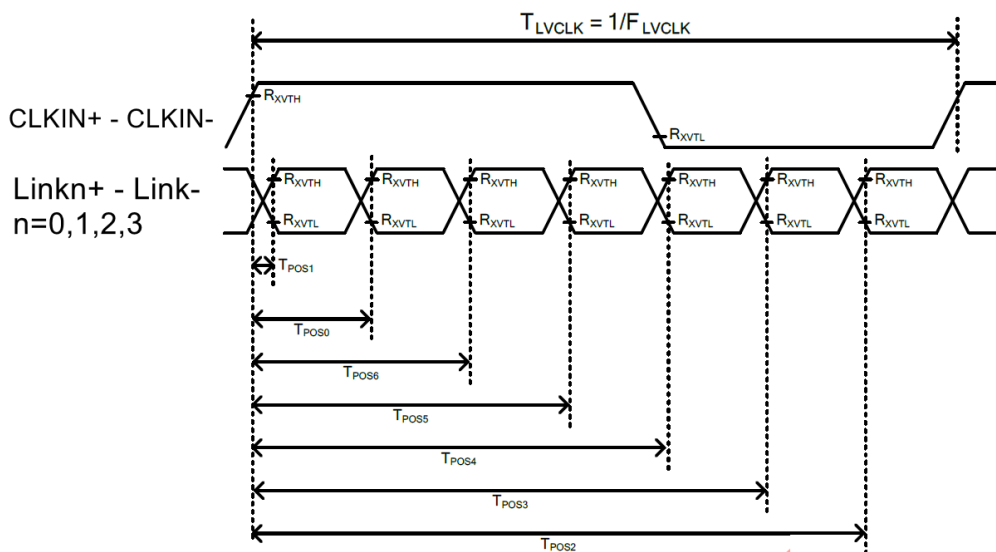

Table 6.1.3 Clock and Data Input Timing Diagram

6.2 Data Input Timing Parameter Setting

DE mode for 1024RGBx768

Parameter		Symbol	Min.	Typ.	Max.	Unit	Remark	
CLK	Frequency	1/tc	50.34	50.66	80	MHz	19.74ns(typ.)	
DE	Horizontal	Display area	thd	1024			CLK	
		Period time	th	-	21.477	-	μs	46.561 kHz (typ.)
	Vertical (One frame)	Display area	tvd	768			H	
		Period time	tv	-	16.666	-	ms	60.0Hz (typ.)
			774	776	1001	H		

Table 6.2.1 Data Input Timing Parameters

6.3 LVDS Interface Timing Characteristics

6.3.1 LVDS Input Data Format 8-bit LVDS VESA

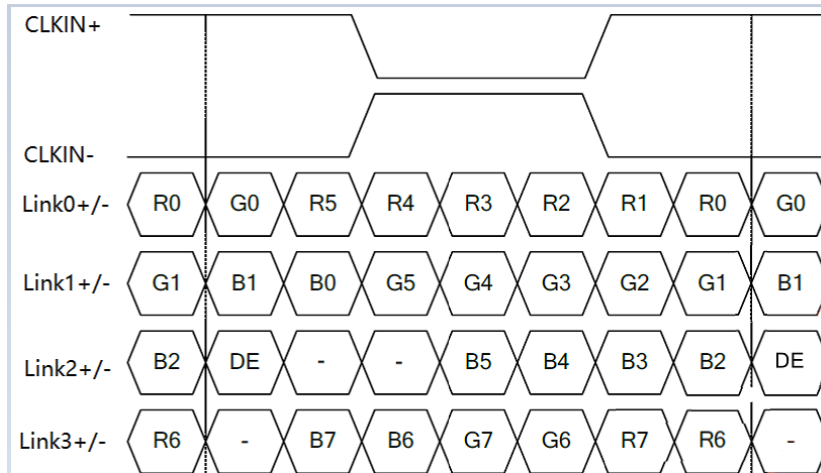

Figure 6.3.1 8-bit LVDS data map

6.3.2 LVDS Input Data Format 6-bit LVDS VESA

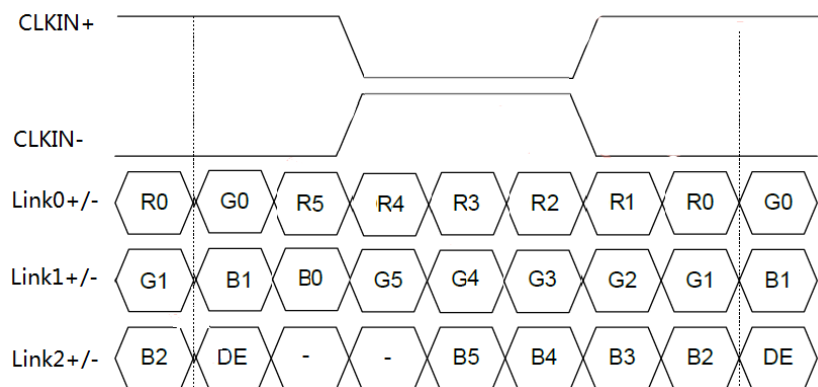

Figure 6.3.2 LVDS data map

6.4 LVDS Input Timing Format

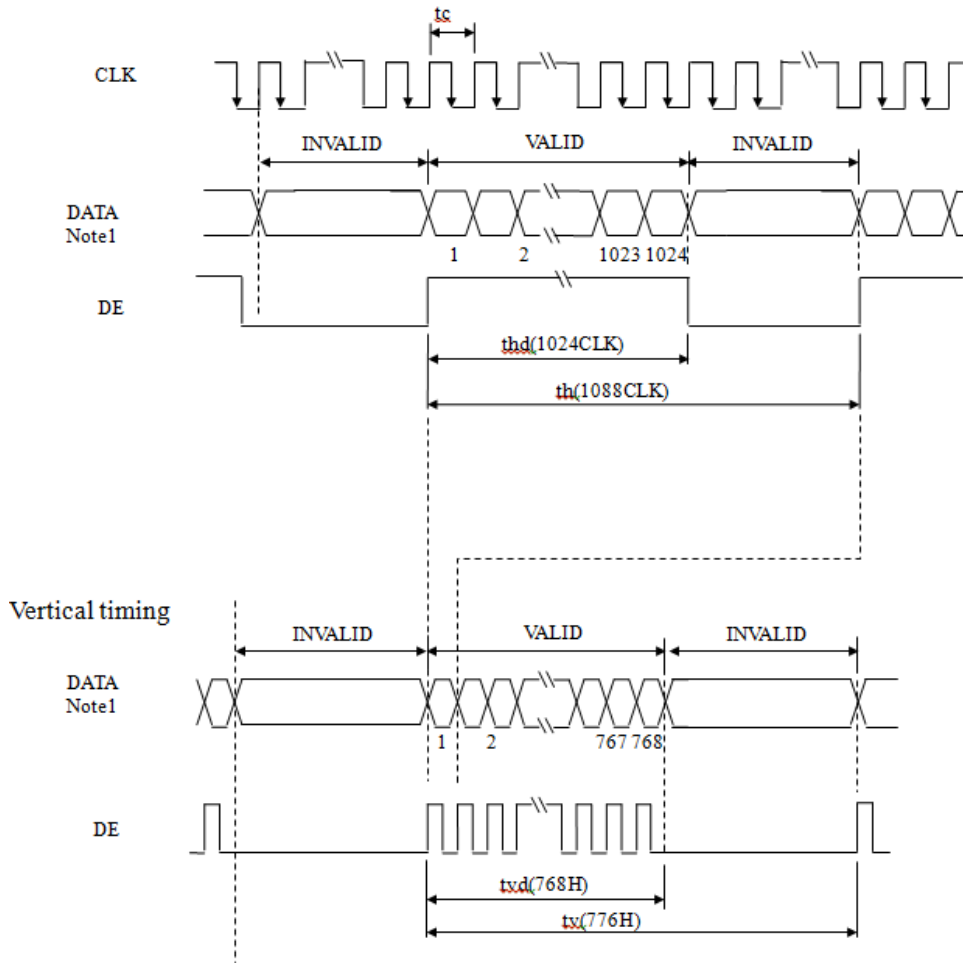

Figure 6.4.1 Recommended input timing of LVDS transmitter

Note1: DATA = R0-R7, G0-G7, B0-B7

7. Optical Characteristics

Item	Symbol	Condition	Min	Typ	Max	Unit	Remark	
View Angles	θT	$CR \geq 10$	80	88	--	Degree	Note2,3	
	θB		80	88	--			
	θL		80	88	--			
	θR		80	88	--			
Contrast Ratio	CR	$\theta=0^\circ$	800	1000	--		Note 3	
Response Time	T_{ON}	25°C	--	25	35	ms	Note 4	
	T_{OFF}							
Chromaticity	White	Backlight is on	x	0.255	0.305	0.355	-	Note 1,5
			y	0.289	0.339	0.389		
	Red		x	0.588	0.638	0.688	-	Note 1,5
			y	0.286	0.336	0.386		
	Green		x	0.236	0.286	0.336	-	Note 1,5
			y	0.569	0.619	0.669		
	Blue		x	0.099	0.149	0.199	-	Note 1,5
			y	0.018	0.068	0.118		
Luminance Uniformity	U	--	75	80	--	%	Note 6	
NTSC		--	65	72	--	%	Note 5	
Luminance	L	--	650	800	--	cd/m ²	Note 7	

Table 7.1 Optical Parameters

Test Conditions:

1. $I_F=65$ mA/LED, and the ambient temperature is 25°C.
2. The test systems refer to Note1 and Note2.

Note1: Definition of optical measurement system.

The optical characteristics should be measured in dark room. After 5 Minutes operation, the optical characteristics are measured at the center point of the LCD screen.

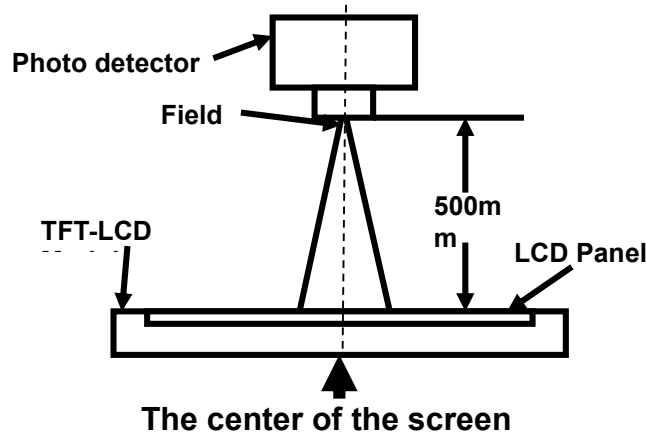

Fig1. Measurement Set Up

Note2: Definition of viewing angle range and measurement system. Viewing angle is measured at the center point of the LCD .

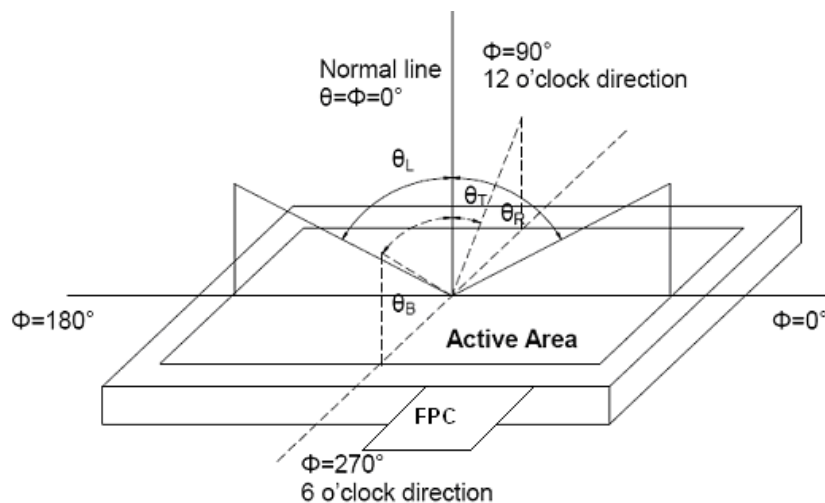

Fig2. Measurement viewing angle

Note3: Definition of contrast ratio

$$\text{Contrast ratio (CR)} = \frac{\text{Luminance measured when LCD is on the "White" state}}{\text{Luminance measured when LCD is on the "Black" state}}$$

Note4: Definition of Response time

For SFT LCM, the response time is defined as the LCD optical switching time interval between “White” state and “Black” state. Rise time (T_r) is the time between photo detector output intensity changed from 10% to 90%. And fall time (T_f) is the time between photo detector output intensity changed from 90% to 10%.

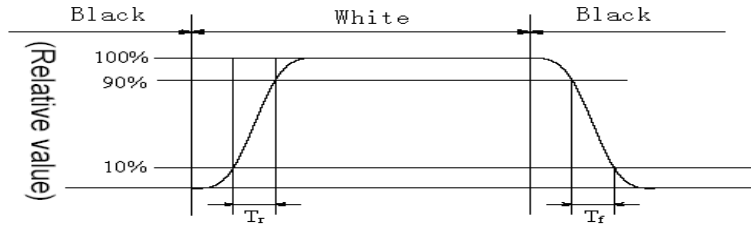

Fig4. Response Time Testing(SFT)

Note5: Definition of color chromaticity (CIE1931)

Color coordinates measured at center point of LCD.

Note6: Definition of Luminance Uniformity

Active area is divided into 9 measuring areas (Refer Fig.5). Every measuring point is placed at the center of each measuring area.

$$\text{Luminance Uniformity (U)} = L_{\min} / L_{\max}$$

L_{\max} : The measured Maximum luminance of all measurement position.

L_{\min} : The measured Minimum luminance of all measurement position.

L -----Active area length; W ----- Active area width

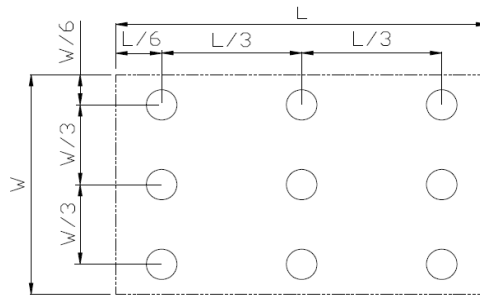

Fig5. Luminance Uniformity Measurement Locations(9 points)

Note7: Definition of Luminance:

Measure the luminance of white state at center point.

8. Reliability Test

No	Test Item	Condition	Remarks
1	High Temperature Operation	Ta = +80°C, 240 hours	IEC60068-2-1 GB2423.2
2	Low Temperature Operation	Ta = -30°C, 240 hours	IEC60068-2-1 GB2423.1
3	High Temperature Storage	Ta = +90°C, 240 hours	IEC60068-2-1 GB2423.2
4	Low Temperature Storage	Ta = -40°C, 240 hours	IEC60068-2-1 GB2423.1
5	Storage at High Temperature and Humidity	Ta = +60°C, 90% RH max, 240 hours	IEC60068-2-78 GB/T2423.3
6	Thermal Shock (non-operation)	-30°C 30 min~+80°C 30 min, Change time: 5min, 100 Cycle	Start with cold temperature, End with high temperature, IEC60068-2-14, GB2423.22
7	ESD	C=150pF, R=330Ω, 9 point/panel Air: ±15KV, 5 times; Contact: ±8KV, 5 times (Environment: 15°C~35°C, 30%RH~60%RH, 86Kpa~106Kpa)	IEC61000-4-2 GB/T17626.2
8	Vibration Test (Non Op)	5~100HZ, 19.60m/s ² 1min/cycle 120 times Per X/Y/Z	IEC60068-2-6 GB/T17626.6
9	Mechanical Shock (Non Op)	539m/s ² , 11ms 5 times ±X, ±Y, ±Z	IEC60068-2-27 GB/T2423.5

Table 8.1 RA test condition

Note1: Ts is the temperature of panel's surface.

Note2: Ta is the ambient temperature of sample.

Note3: Before cosmetic and function test, the product must have enough recovery time, at least 24 hours at room temperature.

Note 4: In the standard condition, there shall be no practical problem that may affect the display function. After the reliability test, only guarantee the operation of the product, but don't guarantee all of the cosmetic specification.

9. Mechanical Drawing

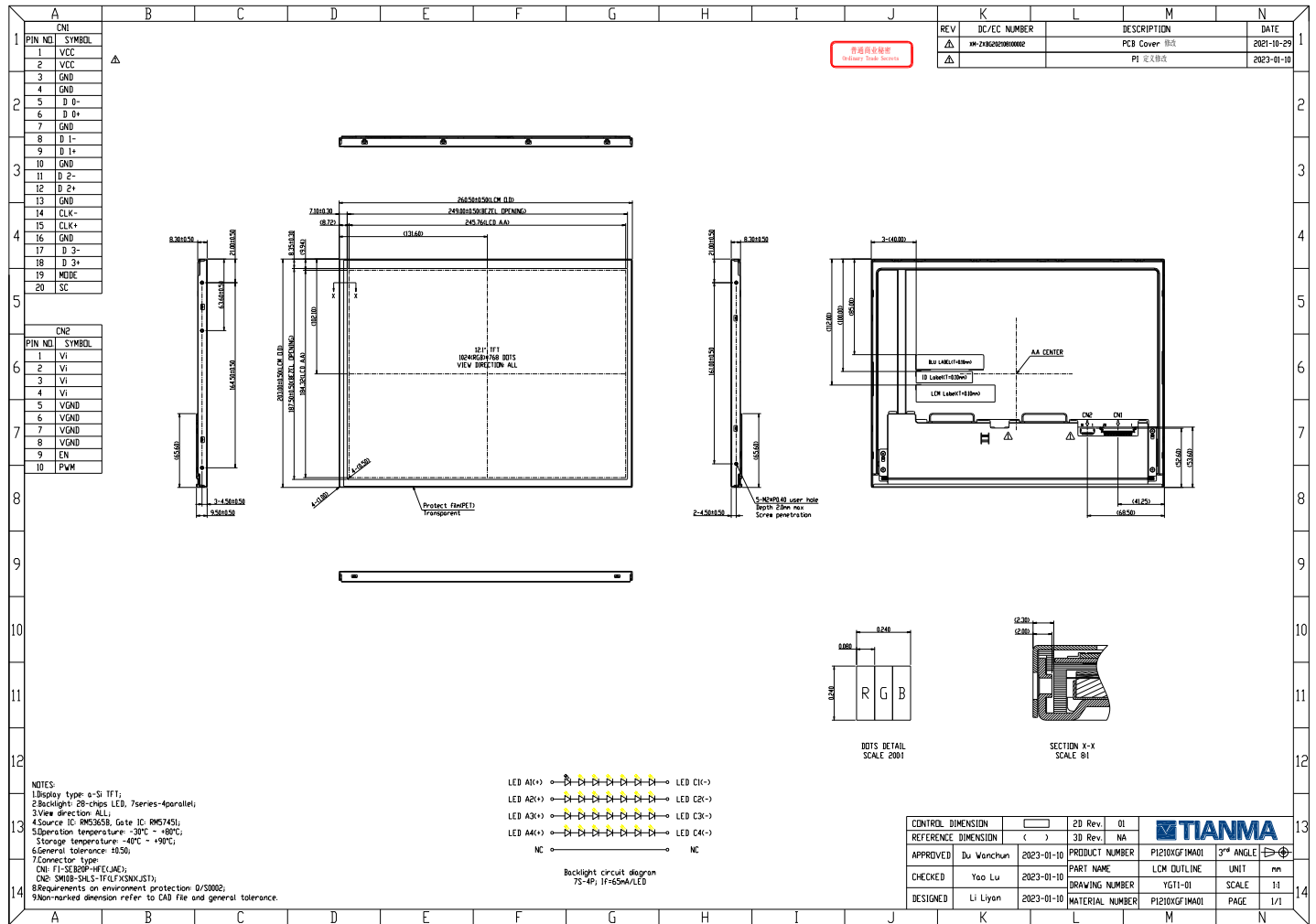

Figure 9.1 Mechanical Drawing

10. Packing Instruction

No	Item	Model (Material)	Dimensions(mm)	Weight(Kg)	Quantity	Remark
1	LCM module	P1210XGF1MA01	260.5×203×9.5	0.550	10	
2	Partition board	Corrugated paper	271×215	0.032	2	
3	Anti-static Bag	LD-PE	435×325×0.05	0.015	10	
4	EPP-Bottom	EPP	430×390×140	0.116	1	
5	EPP-Top	EPP	430×90×40	0.017	1	
6	Carton	Corrugated paper	433×395×310	1.068	1	
7	Total weight	6.915 Kg±5 %				

11. Precautions for Use of LCD Modules

11.1 Handling Precautions

- (1) The display panel is made of glass. Do not subject it to mechanical shock by dropping it, etc.
- (2) If the display panel is damaged and the liquid crystal fluid inside it leaks out be sure not to get any in your mouth. If the fluid comes into contact with your skin or clothes promptly wash it off using soap and water.
- (3) Do not apply excessive force to the display surface or the bezel since this may cause the color tone to vary.
- (4) The polarizer covering the display surface of the LCD module is soft and easily scratched. Handle the polarizer carefully.
- (5) If the display surface is contaminated, breathe on the surface and gently wipe it with a soft dry cloth. If it is still not completely clear use a moist cloth with one of the following solvents:
 - Isopropyl alcohol
 - Ethyl alcoholSolvents other than those mentioned above may damage the polarizer. Specifically, do not use the following:
 - Water
 - Ketone
 - Aromatic solvents
- (6) Do not disassemble the LCD Module.
- (7) If powered off, do not apply the input signals.
- (8) To prevent destruction of the module by static electricity, be careful to maintain an optimum work environment.
- (9) Be sure to ground your body when handling the LCD Modules.
- (10) Tools used for assembly, must be properly grounded.
- (11) To reduce the amount of static electricity generated, do not conduct assembly or other work under very low humidity conditions.
- (12) The LCD Module is covered with a film to protect the display surface, remove film slowly under the ionizer.

11.2 Storage precautions

- (1) When storing the LCD modules avoid exposure to direct sunlight or to the light of fluorescent lamps.
- (2) The LCD modules should be stored within the rated storage temperature range. The recommend condition is: Temperature: 0 ~ 35 °C at normal humidity.
- (3) The LCD modules should be stored in a room without acid, alkali or other harmful gas.

11.3 Transportation Precautions

The LCD modules should not be dropped or subject to violent mechanical shock during transportation. Also they should avoid excessive pressure, water, high humidity and direct sunlight.

11.4 Screen saver Precautions

Not display the fixed pattern for a long time. Use a screen saver, if the fixed pattern is displayed on the screen

11.5 Safety Precautions

- (1) When you waste damaged or unnecessary LCDs, it is recommended to crush LCDs into pieces and wash them off with solvents such as acetone and ethanol, which should later be burned
- (2) Be sure to turn off the power supply when inserting or disconnecting the LED backlight cable.
- (3) LED driver should be designed to limit or stop its function when over current is detected on the LED.

Our company network supports you worldwide with offices in Germany, Austria, Switzerland, the UK and the USA. For more information please contact:

Headquarters

Germany



FORTEC Elektronik AG

Augsburger Str. 2b
82110 Germering

Phone: +49 89 894450-0
E-Mail: info@fortecag.de
Internet: www.fortecag.de

Fortec Group Members

Austria



Distec GmbH Office Vienna

Nuschinggasse 12
1230 Wien

Phone: +43 1 8673492-0
E-Mail: info@distec.de
Internet: www.distec.de

Germany



Distec GmbH

Augsburger Str. 2b
82110 Germering

Phone: +49 89 894363-0
E-Mail: info@distec.de
Internet: www.distec.de

Switzerland



ALTRAC AG

Bahnhofstraße 3
5436 Würenlos

Phone: +41 44 7446111
E-Mail: info@altrac.ch
Internet: www.altrac.ch

United Kingdom



Display Technology Ltd.

Osprey House, 1 Osprey Court
Hichingbrooke Business Park
Huntingdon, Cambridgeshire, PE29 6FN

Phone: +44 1480 411600
E-Mail: info@displaytechnology.co.uk
Internet: www.displaytechnology.co.uk

USA



Apollo Display Technologies, Corp.

87 Raynor Avenue,
Unit 1 Ronkonkoma,
NY 11779

Phone: +1 631 5804360
E-Mail: info@apolloDisplays.com
Internet: www.apolloDisplays.com