Datasheet

ORTUSTECH

COM35H3N82ULC

The information contained in this document has been carefully researched and is, to the best of our knowledge, accurate. However, we assume no liability for any product failures or damages, immediate or consequential, resulting from the use of the information provided herein. Our products are not intended for use in systems in which failures of product could result in personal injury. All trademarks mentioned herein are property of their respective owners. All specifications are subject to change without notice.

Specifications for Blanview TFT-LCD Monitor

Version 1.0

(Please be sure to check the specifications latest version.)

MODEL : COM35H3N82ULC

Customer's Approval
Signature:
Name:
Section:
Title:
Date:

ORTUSTECH

ORTUS TECHNOLOGY CO., LTD.

Approved by

Toshinari Ito

Approved by

N. Mori

Checked by

O. Kimura

Prepared by

M. Ito

Version History

Date	Page	Description	
Mar. 19, 2015	-	-	First issue

Contents

1. Application	4
2. Outline Specifications		
2.1 Features of the Product	5
2.2 Display Method	5
3. Dimensions and Shape		
3.1 Dimensions	7
3.2 Outward Form	8
3.3 Serial № print (S-print)	9
4. Pin Assignment	10
5. Block Diagram	11
6. Absolute Maximum Rating	12
7. Recommended Operating Conditions	12
8. Characteristics		
8.1 DC Characteristics	13
8.2 AC Characteristics	15
8.3 Input Timing Characteristics	18
8.4 Input Signal Timing Chart	19
9. About MIPI Interface		
9.1 Version	20
9.2 DSI protocol	20
9.3 Packet data types	21
9.4 Packet Footer on the long packet	21
9.5 Instruction List	22
10. Sequence		
10.1 Power-ON Sequence	33
10.2 Power-OFF Sequence	37
10.3 Sleep Sequence	37
10.4 Sleep Release Sequence	37
10.5 ID Read Sequence	37
10.6 Power ON/OFF timing	38
10.7 Refresh Sequence	39
11. Characteristics		
11.1 Optical Characteristics	44
11.2 Temperature Characteristics	45
12. Criteria of Judgment		
12.1 Defective Display and Screen Quality	46
12.2 Screen and Other Appearance	47
13. Reliability Test	48
14. Packing Specifications	50
15. Handling Instruction		
15.1 Cautions for Handling LCD panels	51
15.2 Precautions for Handling	52
15.3 Precautions for Operation	52
15.4 Storage Condition for Shipping Cartons	53
15.5 Precautions for Peeling off the Protective film	53
APPENDIX	54

1. Application

This Specification is applicable to 8.88cm (3.5 inch) Blanview TFT-LCD monitor for non-military use.

- ◎ ORTUS TECHNOLOGY makes no warranty or assume no liability that use of this Product and/or any information including drawings in this Specification by Purchaser is not infringing any patent or other intellectual property rights owned by third parties, and ORTUS TECHNOLOGY shall not grant to Purchaser any right to use any patent or other intellectual property rights owned by third parties. Since this Specification contains ORTUS TECHNOLOGY's confidential information and copy right, Purchaser shall use them with high degree of care to prevent any unauthorized use, disclosure, duplication, publication or dissemination of ORTUS TECHNOLOGY'S confidential information and copy right.
- ◎ If Purchaser intends to use this Products for an application which requires higher level of reliability and/or safety in functionality and/or accuracy such as transport equipment (aircraft, train, automobile, etc.), disaster-prevention/security equipment or various safety equipment, Purchaser shall consult ORTUS TECHNOLOGY on such use in advance.
- ◎ This Product shall not be used for application which requires extremely higher level of reliability and/or safety such as aerospace equipment, telecommunication equipment for trunk lines, control equipment for nuclear facilities or life-support medical equipment.
- ◎ It must be noted as a mechanical design manner, especial attention in housing design to prevent arcuation/flexure or caused by stress to the LCD module shall be considered.
- ◎ ORTUS TECHNOLOGY assumes no liability for any damage resulting from misuse, abuse, and/or miss-operation of the Product deviating from the operating conditions and precautions described in the Specification.
- ◎ ORTUS TECHNOLOGY is not responsible for any nonconformities and defects that are not specified in this specifications.
- ◎ If any issue arises as to information provided in this Specification or any other information, ORTUS TECHNOLOGY and Purchaser shall discuss them in good faith and seek solution.
- ◎ ORTUS TECHNOLOGY assumes no liability for defects such as electrostatic discharge failure occurred during peeling off the protective film or Purchaser's assembly process.
- ◎ This Product is compatible for RoHS directive.

Object substance	Maximum content [ppm]
Cadmium and its compound	100
Hexavalent Chromium Compound	1000
Lead & Lead compound	1000
Mercury & Mercury compound	1000
Polybrominated biphenyl series (PBB series)	1000
Polybrominated biphenyl ether series (PBDE series)	1000

2. Outline Specifications

2.1 Features of the Product

- 3.5 inch diagonal display, 1440 [H] x 640 [V] dots.
- 24bitRGB (8-8-8 Format) / 16.7 Million colors.
- MIPI DSI as high-speed interface. Video mode only.
- Timing generator [TG], Counter-electrode driving circuitry, Built-in power supply circuit.
- Various display controls and functional selection.
- High bright white LED back-light.
- Blanview TFT-LCD, improved outdoor readability.

* MIPI : Mobile Industrial Processor Interface , DSI : Display Serial Interface

	Indoor		Outdoor	
	Readability	Power Efficiency (Battery Life)	Readability	Power Efficiency (Battery Life)
Transmissive	Good	Good	Fair	Poor
Transflective	Fair	Poor	Good	Good
Blanview	Good	Good	Good	Good

2.2 Display Method

Items	Specifications	Remarks
Display type	16.7million colors. Blanview, Normally black.	
Driving method	a-Si TFT Active matrix. Line-scanning, Non-interlace.	
Dot arrangement	RGB stripe arrangement.	Refer to "Dot arrangement"
Signal input method	MIPI DSI 2-lanes : 2 data lanes and 1 clock lane	
Backlight type	High bright white LED.	

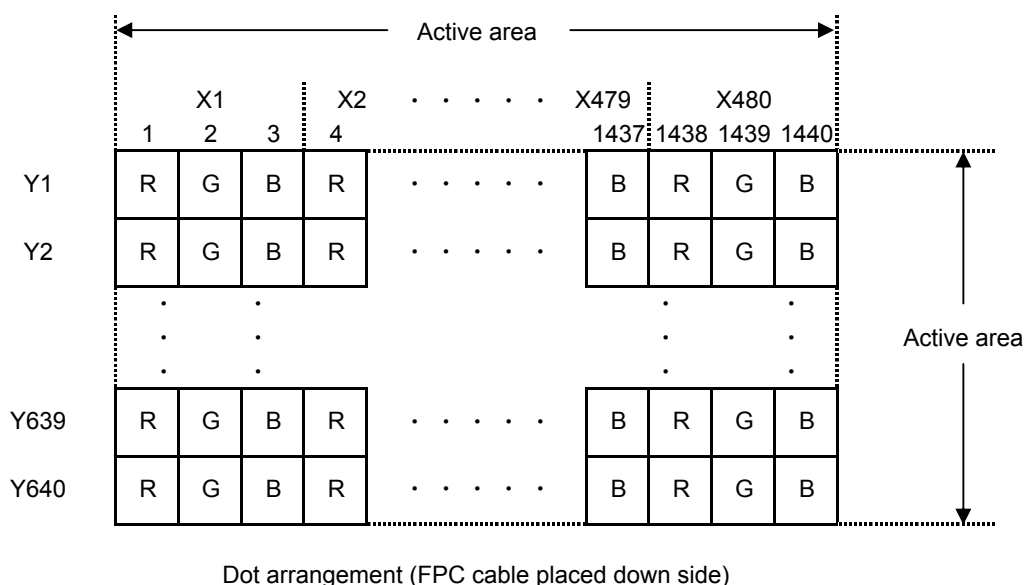

<Features of Blanview>

- Backlight power consumption required to assure visibility. (equivalent to 3.5"QVGA)

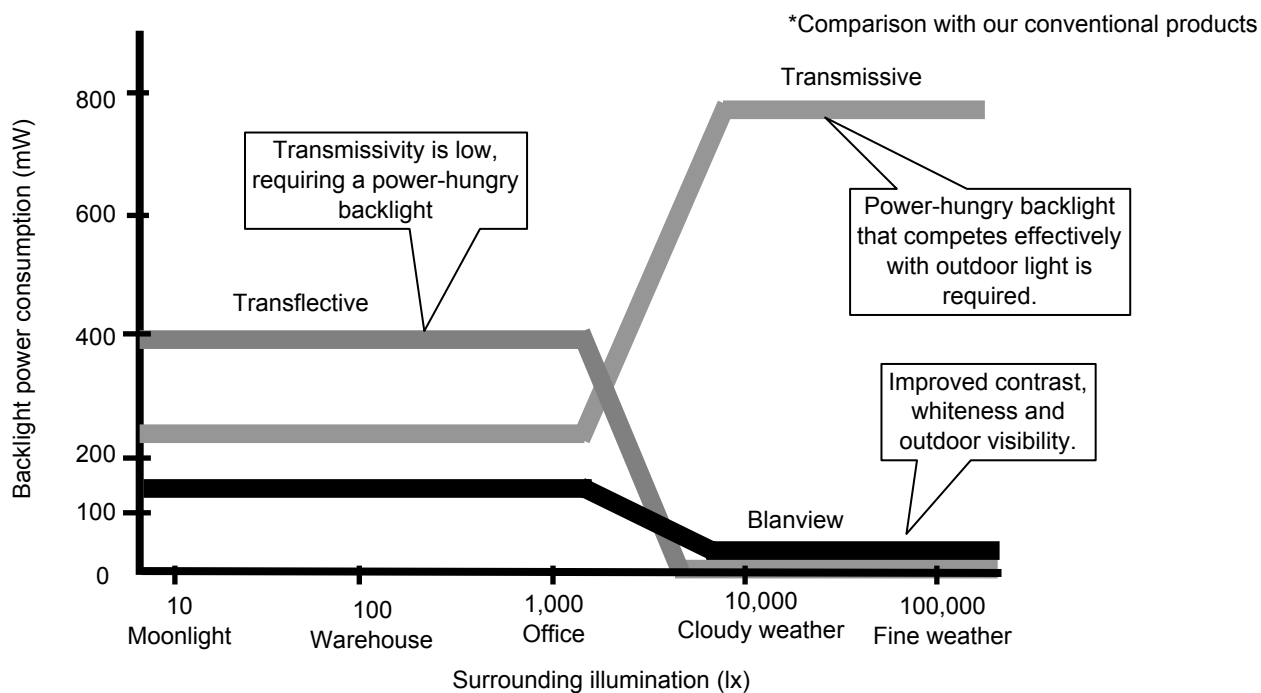

- Contrast characteristics under 100,000lx. (same condition as direct sunlight.)

With better contrast (higher contrast ratio), Blanview TFT-LCD has the best outdoor readability in three different types of TFT-LCD.

Below chart shows contrast value against panel surface brightness. (Horizontal: Panel surface brightness/ Vertical: Contrast value) LCD panel has enough outdoor readability above our Standard line. (ORTUS TECHNOLOGY criteria)

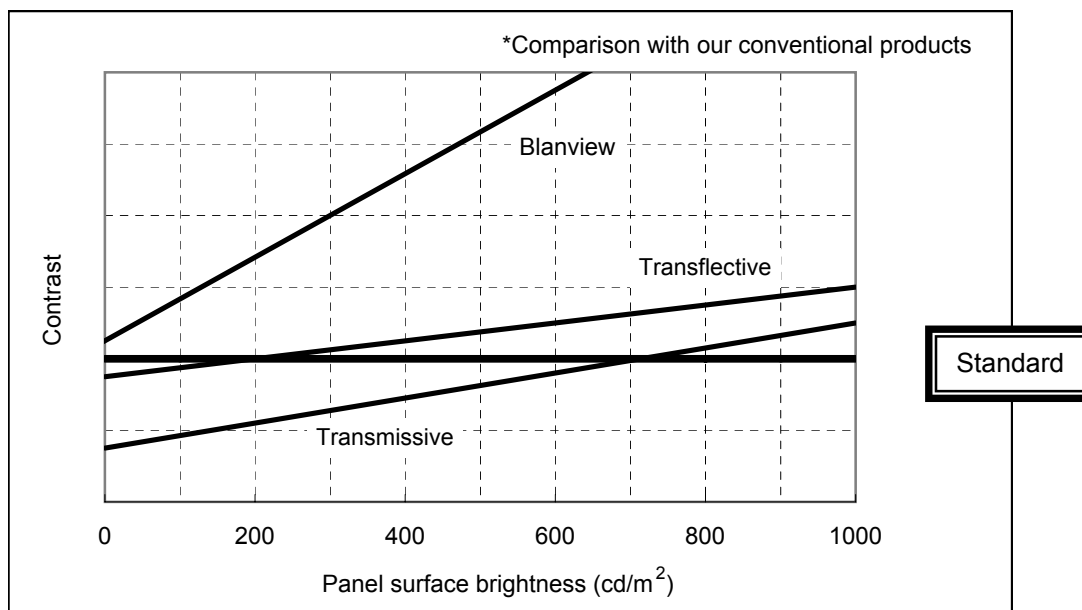

3. Dimensions and Shape

3.1 Dimensions

Items	Specifications	Unit	Remarks
Outline dimensions	61.00 [H] × 81.75 [V] × 2.60 [D]	mm	Exclude FPC cable and parts on FPC.
Active area	53.28[H] × 71.04[V]	mm	
Number of dots	1440[H] × 640[V]	dot	
Dot pitch	37[H] × 111[V]	um	
Surface hardness of the polarizer	2	H	Load:2.0N
Weight	27.7	g	Include FPC cable

3.2 Outward Form

EC No.	REV.No.	REVISE	DATE (Y:M:D)	APPROVED	CHECKED	PREPARED
--------	---------	--------	--------------	----------	---------	----------

(8/56)
15TLM020
Issue:Mar.19,2015

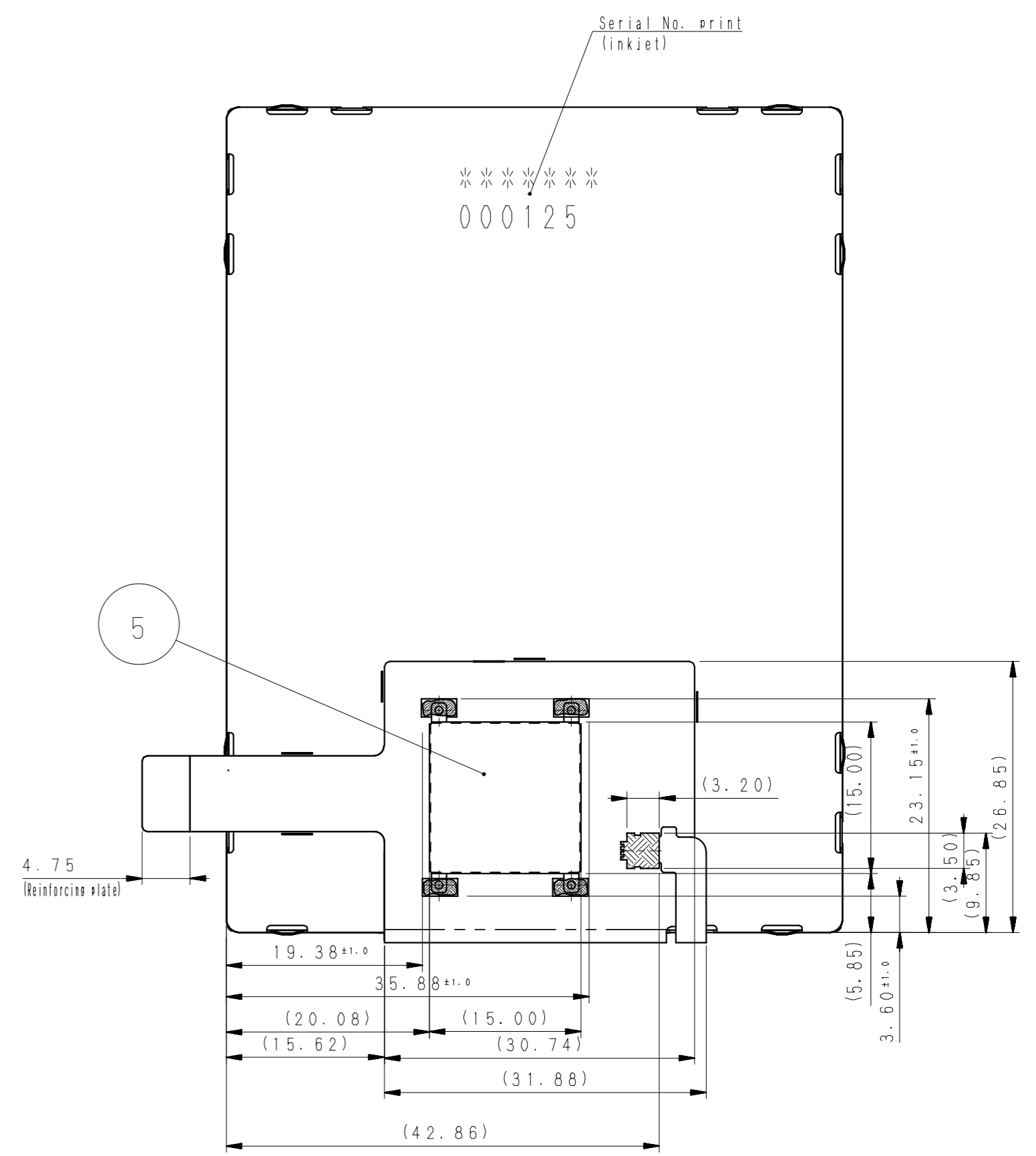
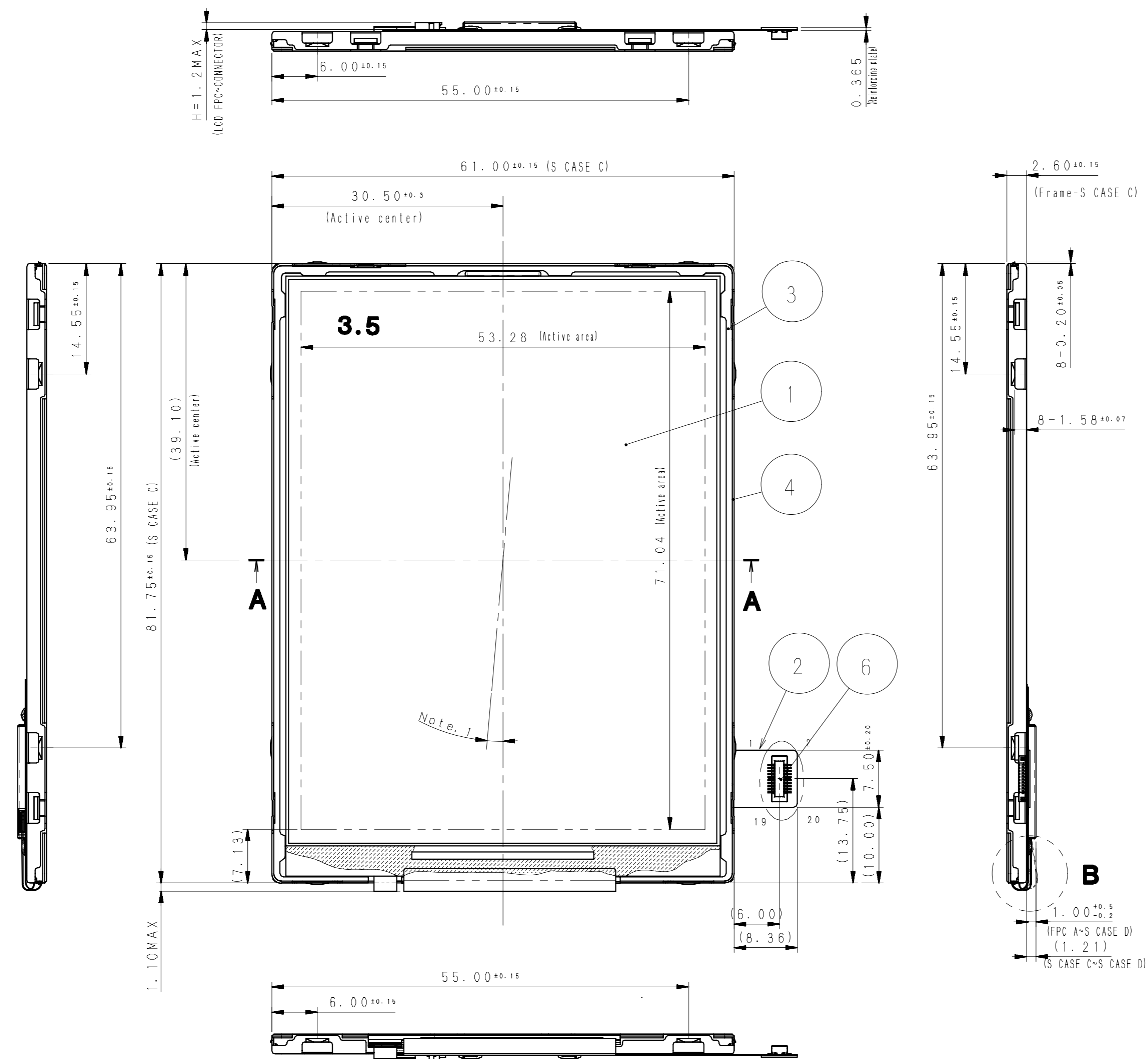

Note 1. Angular deviation of LCD cell from the TFT-LCD monitor's reference axis shall be less than $\pm 50'$.

	9			
	8			
	7			
CONNECTOR	6	559090274 Molex		User side:513380274 Molex
S CASE D	5			
S CASE C	4		SUS (t=0.20)	
Frame	3		PC	
FPC A	2			
TFT-LCD	1			Glass thickness=0.50±0.50t
PART NAME	ITEM	PART CODE	MODEL NUMBER	REMARK
APPROVED 橋爪	GENERAL TOLERANCE ± 0.5	SCALE 2/1	UNIT m.m	ORTUSTECH ORTUS TECHNOLOGY CO.,LTD. DO NOT DUPLICATE, CONFIDENTIAL AND PROPRIETARY
CHECKED 平信	ISSUE (Y:M:D) 15:02:20	MODEL COM35H3N82U**		
CHECKED	NAME			
DESIGN 小林宣幸				
DRAW 小林宣幸				
		OUTLINE-D3N82	RJD525521D201	

3.3 Serial № print (S-print)

1) Display Items

S-print indicates the least significant digit of manufacture year (1digit), manufacture month with below alphabet (1letter), model code (5characters), serial number (6digits).

* Contents of Display

*	*	*****	*****
-	-	-	-
a	b	c	d

Contents of display				
a	The least significant digit of manufacture year			
b	Manufacture month	Jan-A Feb-B Mar-C Apr-D	May-E Jun-F Jul-G Aug-H	Sep-I Oct-J Nov-K Dec-L
c	Model code	35LDC (Made in Japan) 35LEC (Made in Malaysia)		
d	Serial number			

* Example of indication of Serial № print (S-print)

•Made in Japan

5J35LDC000125

means "manufactured in October 2015, 3.5" LD type, C specifications, serial number 000125"

•Made in Malaysia

5J35LEC000125

means "manufactured in October 2015, 3.5" LE type, C specifications, serial number 000125"

2) Location of Serial № print (S-print)

Refer to 3.2 "Outward Form".

3)Others

Please note that it is likely to disappear with an organic solvent about the Serial print.

4. Pin Assignment

No.	Symbol	Details	Remark	IO
1	GND	Ground		P
3	D0_N	MIPI-DSI Data differential signal input pin (Data lane 0)		IO
5	D0_P	MIPI-DSI Data differential signal input pin (Data lane 0)		IO
7	GND	Ground		P
9	CLK_N	MIPI-DSI Clock differential signal input pin		I
11	CLK_P	MIPI-DSI Clock differential signal input pin		I
13	GND	Ground		P
15	D1_N	MIPI-DSI Data differential signal input pin (Data lane 1)		I
17	D1_P	MIPI-DSI Data differential signal input pin (Data lane 1)		I
19	GND	Ground		P
2	LED-	Backlight LED Cathode		P
4	LED+	Backlight LED Anode		P
6	VDD	DSI and Analog Power Supply	VDD = 2.8V (TYP)	P
8	VDD	DSI and Analog Power Supply	VDD = 2.8V (TYP)	P
10	VCCIO	I/O Power Supply	VCCIO = 1.8V (TYP)	P
12	GND	Ground		P
14	GND	Ground		P
16	LEDPWM	PWM output		O
18	RESX	LCD Reset	L:Initialize Power_ON Reset is Required when Turning on the Power	I
20	TEST	OTP_PWR	Please nonnect this pin to VDD(2.8V)	P

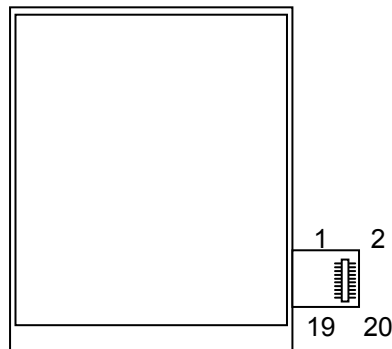

- Recommended connector : (Molex / 513380274)
- Since FPC cable has gold plated terminals, gilt finish contact shoe connector is recommended.

5. Block Diagram

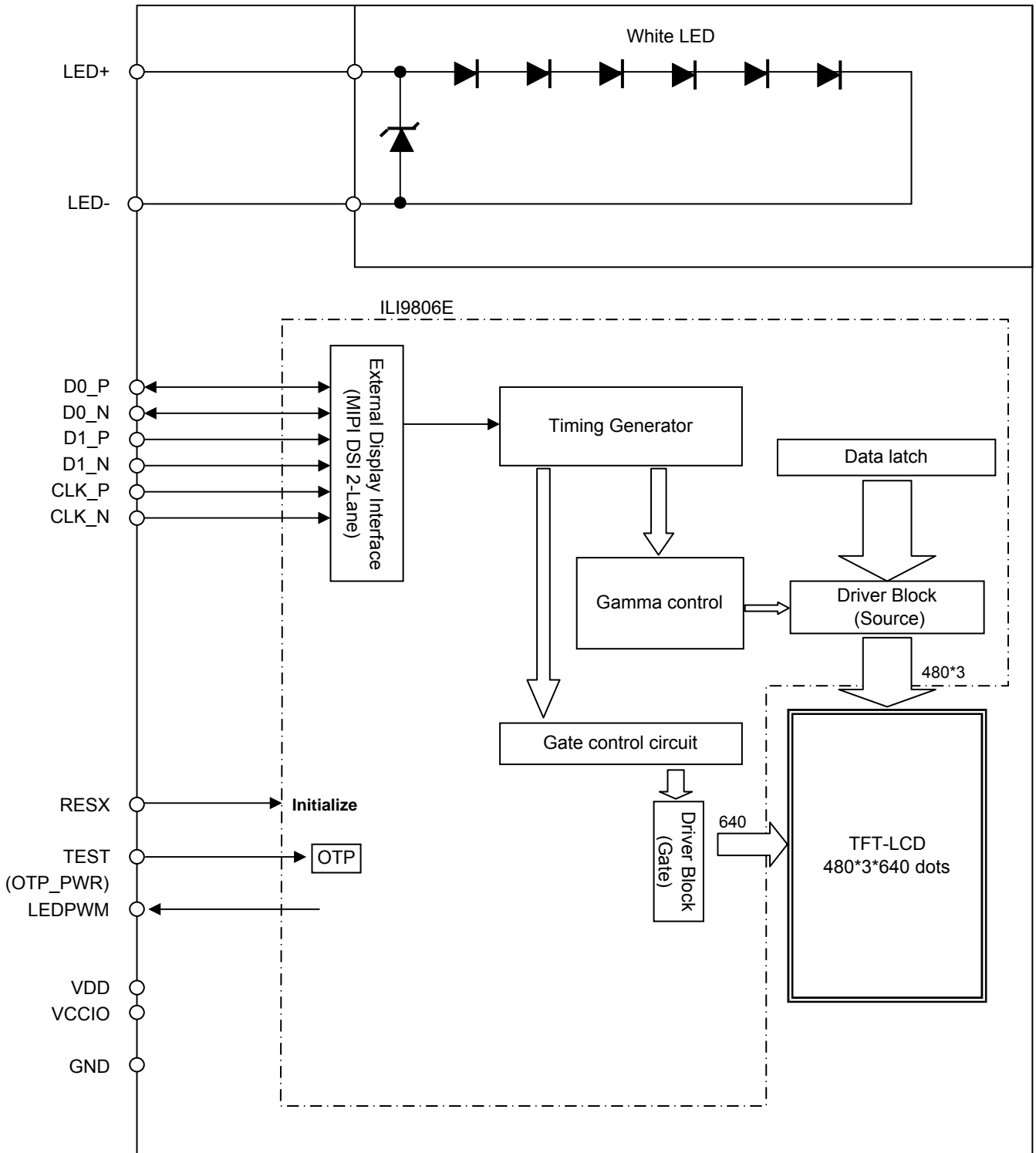

6. Absolute Maximum Rating

GND=0V

Item	Symbol	Condition	Rating		Unit	Applicable terminal
			MIN	MAX		
Supply voltage	VDD	Ta = 25 °C	-0.3	4.6	V	VDD
Logic interface voltage	VCCIO		-0.3	VDD	V	VCCIO
Input voltage for logic	VI		-0.3	VCCIO+0.3	V	RESX
Output voltage for logic	VO		-0.3	VCCIO+0.3	V	LEDPWM
HS Input voltage	VHSIN		-0.3	2.0	V	D0_P/N , D1_P/N CLK_P/N
Forward current	IL	Ta = 25 °C	--	35	mA	LED+,LED-
		Ta = 70 °C	--	15		
Storage temperature rang	Tstg		-30	80	°C	
Storage humidity range	Hstg	Non condensing in an environmental moisture at or less than 40 °C 90%RH.				

7. Recommended Operating Conditions

GND=0V

Item	Symbol	Condition	Rating			Unit	Applicable terminal
			MIN	TYP	MAX		
Supply voltage	VDD	Ta = 25 °C	2.7	2.8	2.9	V	VDD
Logic interface voltage	VCCIO		1.7	1.8	1.9	V	VCCIO
Input voltage for logic	VI		0	--	VCCIO	V	RESX
output voltage for logic	VO		0	--	VCCIO	V	LEDPWM
Operational temperature range	Top	Note1,2	-20	25	70	°C	Panel surface temperature
Operating humidity range	Hop	Ta<=30 °C	20	-	80	%	
		Ta>30 °C	Non condensing in an environmental moisture at or less than 30 °C 80%RH.				

Note1: This monitor is operable in this temperature range. With regard to optical characteristics, refer to Item 11."CHARACTERISTICS".

Note2: Acceptable Forward Current to LED is up to 15 mA, when Ta=+70 °C.
Do not exceed Allowable Forward Current shown on the chart below.

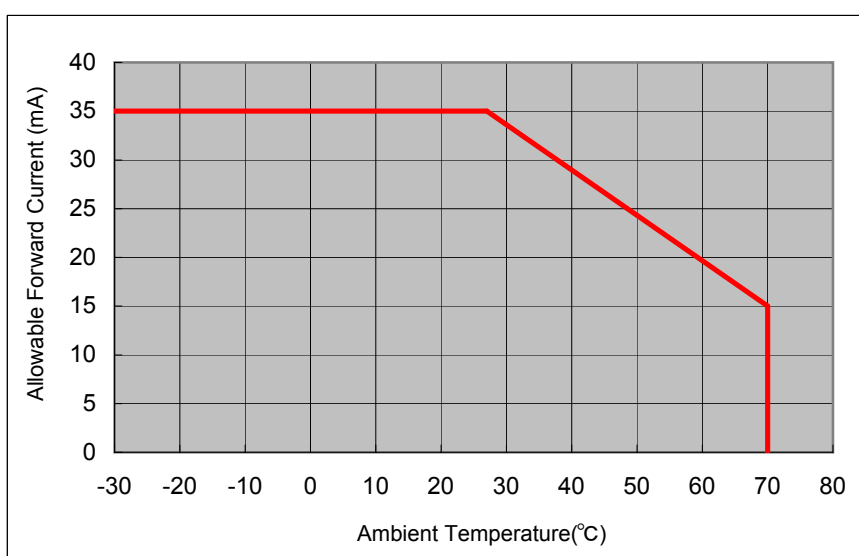

8. Characteristics

8.1 DC Characteristics

8.1.1 Display Module

(Unless otherwise noted, Ta=25 °C, VDD=2.8V, VCCIO=1.8V, GND=0V)

Item	Symbol	Condition	Rating			Unit	Applicable terminal
			MIN	TYP	MAX		
Input Signal Voltage	VIH	VCCIO=1.7-1.9V	0.7×VCCIO	--	VCCIO	V	RESX
	VIL		0	--	0.3×VCCIO	V	
Operating Current	IVDD	fPCLK=19.8MHz	--	27	54	mA	VDD
	IVCCIO	Color bar display	--	10	20	uA	VCCIO
Stand-by Current	IVDD	Other input with constant voltage	--	30	60	uA	VDD
	IVCCIO		--	--	20	uA	VCCIO

8.1.2 MIPI DSI Interface

Item	Symbol	Condition	Rating			Unit	Note	
			MIN	TYP	MAX			
HS-RX	Differential input high threshold	VIDTH	-	-	70	mV		
	Differential input low threshold	VIDTL	-70	-	-	mV		
	Single-ended input high voltage	VIHHS	-	-	460	mV		
	Single-ended input low voltage	VILHS	-40	-	-	mV		
	Common-mode voltage HS receive mode	VCMRXDC		70	-	330	mV	
	Differential input impedance	ZID		80	100	125	Ohm	
LP-RX	Logic 1 input voltage	VIH	880	-	-	mV		
	Logic 0 input voltage	VIL	-	-	550	mV		
LP-TX	Thevenin output low level	VOL	-50	-	50	mV		
	Thevenin output high level	VOH	1.1	1.2	1.3	V		
CD-RX	Logic 1 contention threshold	VIHCD	450	-	-	mV		
	Logic 0 contention threshold	VILCD	-	-	200	mV		

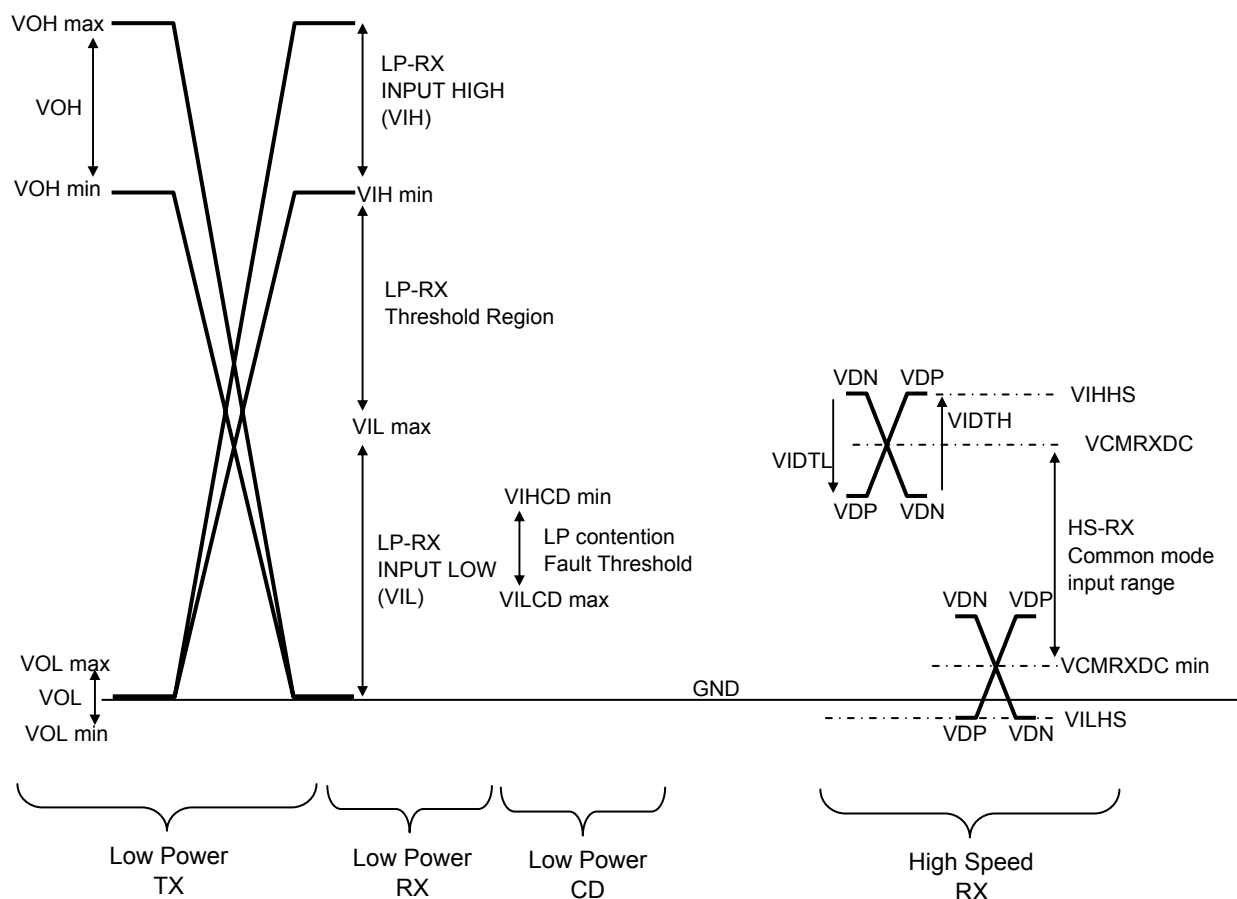

Fig.A The signal levels for the LP and HS .

8.1.3 Backlight

Item	Symbol	Condition	Rating			Unit	Applicable terminal
			MIN	TYP	MAX		
Forward current	IL25	Ta=25 °C	—	20	35	mA	LED+,LED-
	IL70	Ta=70 °C	—	—	15	mA	
Forward voltage	VL	Ta=25 °C IL=20.0mA	—	17.4	19.2	V	
Estimated Life of LED	LL	Ta=25 °C IL=20mA Note	--	10000	--	hrs	

- Note: - The lifetime of the LED is defined as a period till the brightness of the LED decreases to the half of its initial value.
- This figure is given as a reference purpose only, and not as a guarantee.
 - This figure is estimated for an LED operating alone.
- As the performance of an LED may differ when assembled as a monitor together with a TFT panel due to different environmental temperature.
- Estimated lifetime could vary on a different temperature and usually higher temperature could reduce the life significantly.

8.2 AC Characteristics

8.2.1 HS-RX Specifications

(Unless otherwise noted, $T_a=25\text{ }^\circ\text{C}$, $V_{DD}=2.8\text{V}$, $V_{CCIO}=1.8\text{V}$, $GND=0\text{V}$)

Item	Symbol	Condition	Rating			Unit	Applicable terminal
			MIN	TYP	MAX		
DSICLK Frequency	f DSICLK	Fig.B	40	-	250	MHz	CLK_P/N
DSICLK Cycle time	TCLKP		4.0	-	25.0	ns	
DSI Data Transfer Rate	UI		2.0	-	12.5	ns	D0_P/N , D1_P/N
	t DSIR		80	-	500	Mbps	
Data to Clock Setup Time	Tsetup		0.15	-	-	UI	D0_P/N , D1_P/N
Clock to Data Hold Time	Thold	0.15	-	-	UI	CLK_P/N	

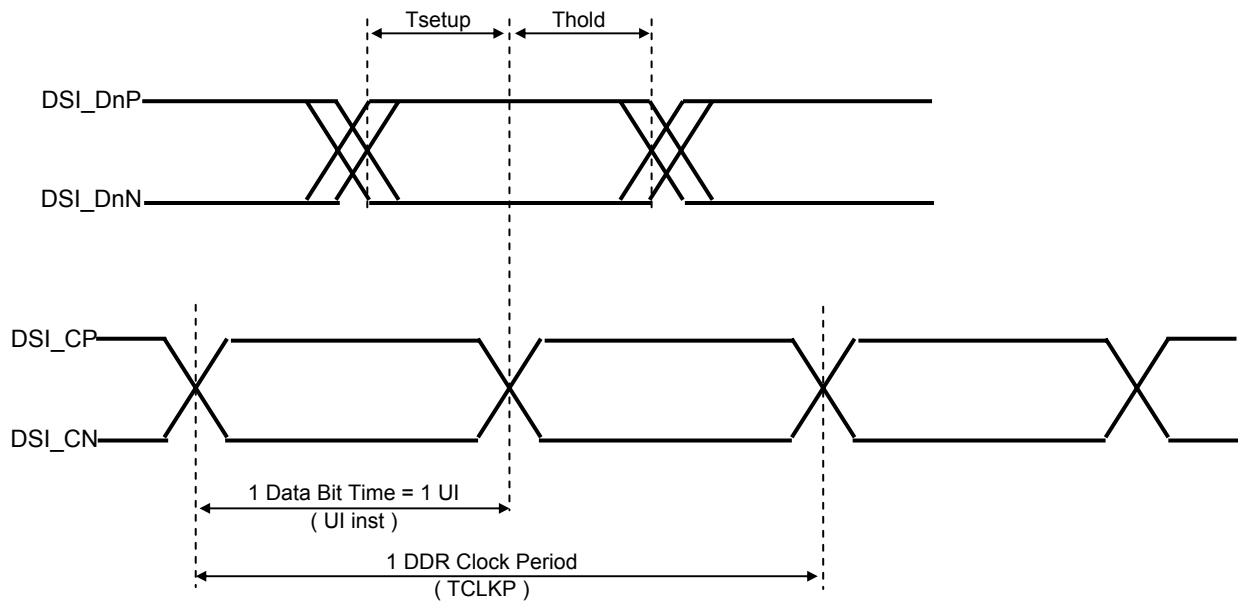

Fig.B Data to Clock Timing Definitions

8.2.2 RX/TX Specifications

(Unless otherwise noted, $T_a=25\text{ }^\circ\text{C}$, $V_{DD}=2.8\text{V}$, $V_{CCIO}=1.8\text{V}$, $GND=0\text{V}$)

Item	Description	Rating			Unit
		MIN	TYP	MAX	
$T_{\text{HS-PREPARE}}$	Time to drive LP00 to prepare for HS transmission	40 ns + 4UI	-	85 ns + 6UI	
$T_{\text{HS-EXIT}}$	Time to drive LP11 after HS burst	100	-	-	ns
$T_{\text{TA-SURE}}$	Time out before new TX side starts driving	TLPTX	-	$2 \cdot T_{\text{LPTX}}$	
T_{LPX}	Length of any Low Power state period	50	-	-	ns
$T_{\text{CLK-POST}}$	Time that the transmitter shall continue sending HS clock after the last associated Data Lane has transitioned to LP mode	60 ns + 52UI	-	-	
$T_{\text{CLK-PRE}}$	Time that the HS clock shall be driven prior to any associated Data Lane beginning the transition from LP to HS mode	8	-	-	UI
$T_{\text{CLK-PREPARE}}$	Time to drive LP-00 to prepare for HS clock transmission	38	-	95	ns
$T_{\text{CLK-TRAIL}}$	Time to drive HS differential state after last payload clock bit of a HS transmission burst	60	-	-	ns

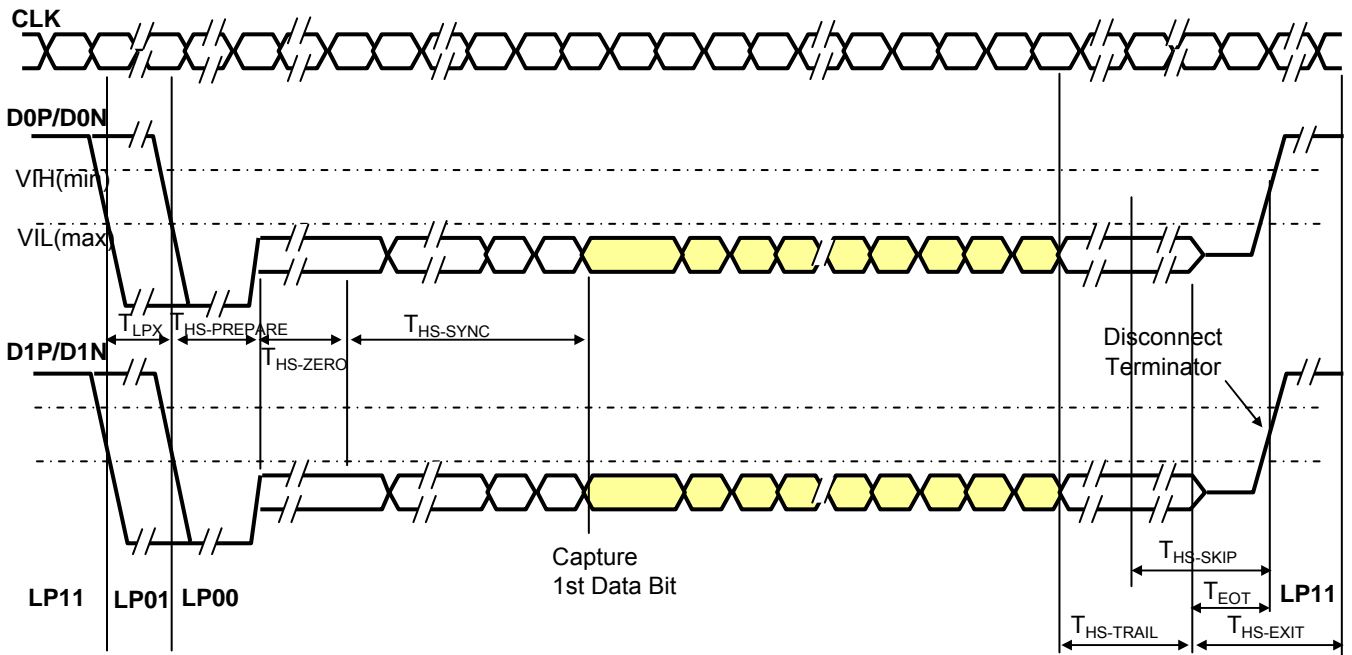

Fig.C HS Data Transmission in Bursts

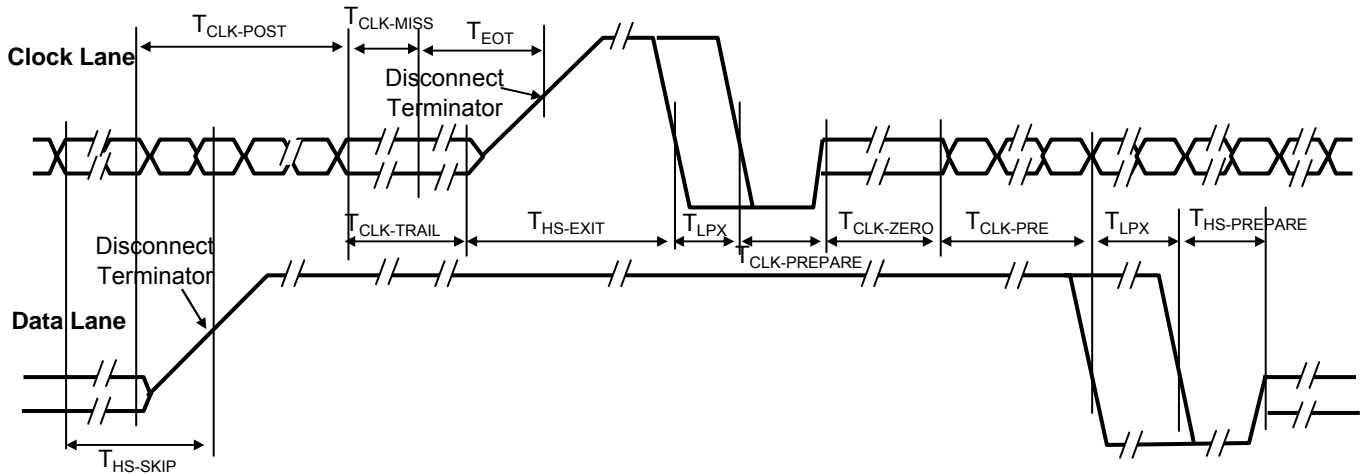

Fig.D Switching the Clock Lane between Clock Transmission and LP mode

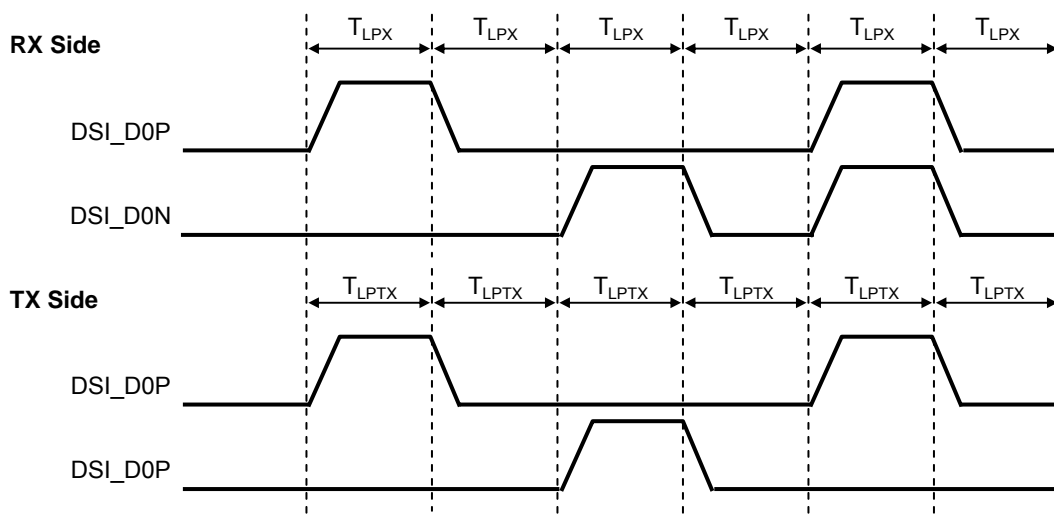

Fig.E DSI LP Mode

8.2.3 Reset input timing

Item	Symbol	Condition	Rating			Unit	Remark
			MIN	TYP	MAX		
Reset Low Pulse width	tRW		10	-	-	us	
Reset Complete time	tRT	during Sleep In	-	-	5	ms	
		during Sleep Out	-	-	120	ms	

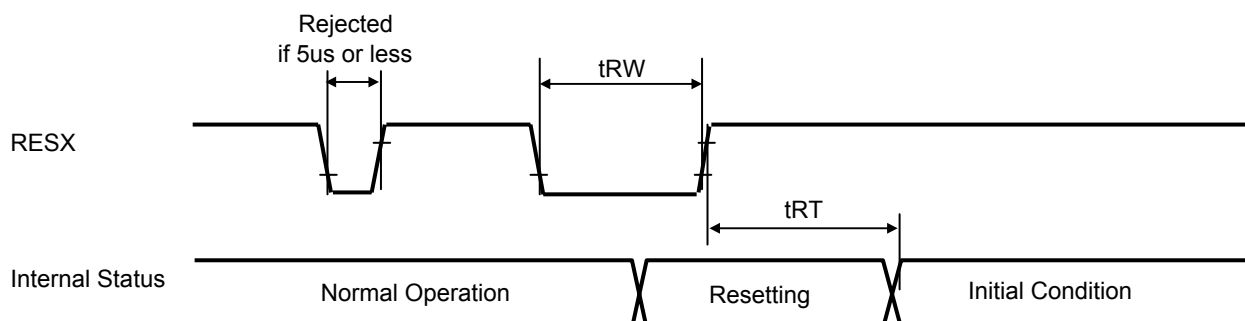

Fig.F RESETB input timing

8.3 Input Timing Characteristics

Item	Symbol	Condition	Rating			Unit	Remark
			MIN	TYP	MAX		
CLK Frequency	fPCLK	Fig.G	16.2	22.4	26.3	MHz	PCLK
VSYNC Frequency	Note fVSYNC		57	59.6	63	Hz	VSYNC
VSYNC Cycle	tv		--	712	---	H	
VSYNC Pulse Width	tvS		2	4	4	H	
Vertical Back Porch	tvb		4	16	--	H	
Vertical Front Porch	tvf		2	52	--	H	
Vertical Blanking Period	tvb+tvf		6	--	--	H	
VS Pulse & Vertical Back Porch	ts+tvb		20	20	20	H	
Vertical Display Period	tvdp		--	640	--	H	
HSYNC frequency	fHSYNC		--	42.4	--	kHz	HSYNC
HSYNC Cycle	th		--	528	--	CLK	
HSYNC Pulse Width	ths		5	16	80	CLK	
Horizontal Back Porch	thb		10	16	85	CLK	
Horizontal Front Porch	thf	5	16	80	CLK		
Horizontal Blanking Period	thb+thf	15	--	90	CLK		
Horizontal Display Period	thdp	--	480	--	CLK		

Note: This is recommended spec to get high quality picture on display. It is customer's risk to use out of this frequency.

8.4 Input Signal Timing Chart

-Vertical Timing

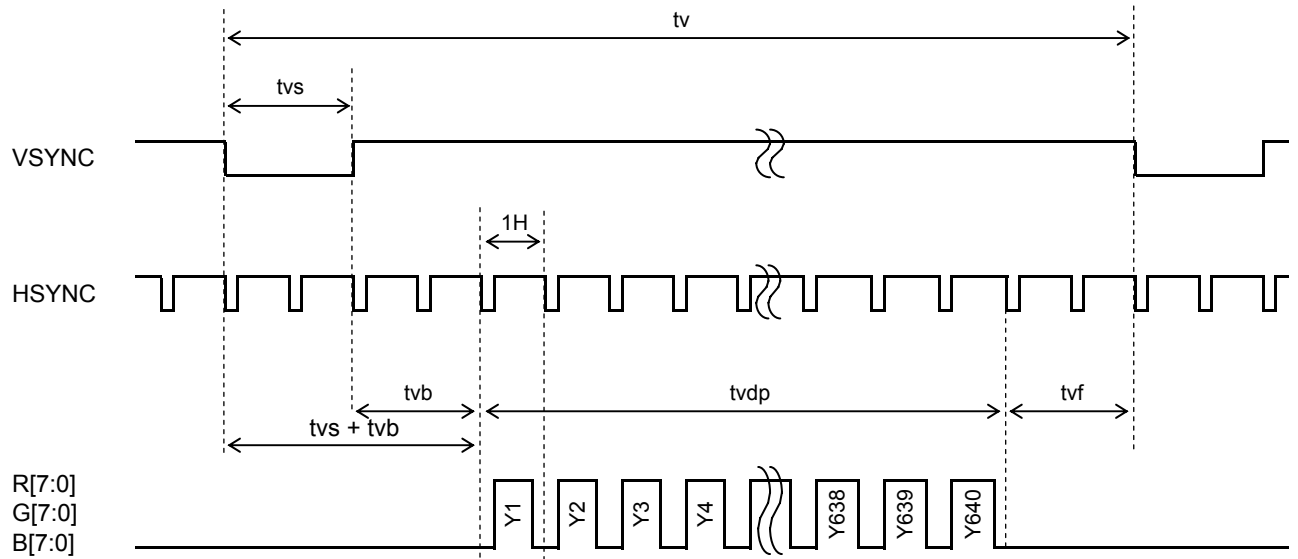

-Horizontal Timing

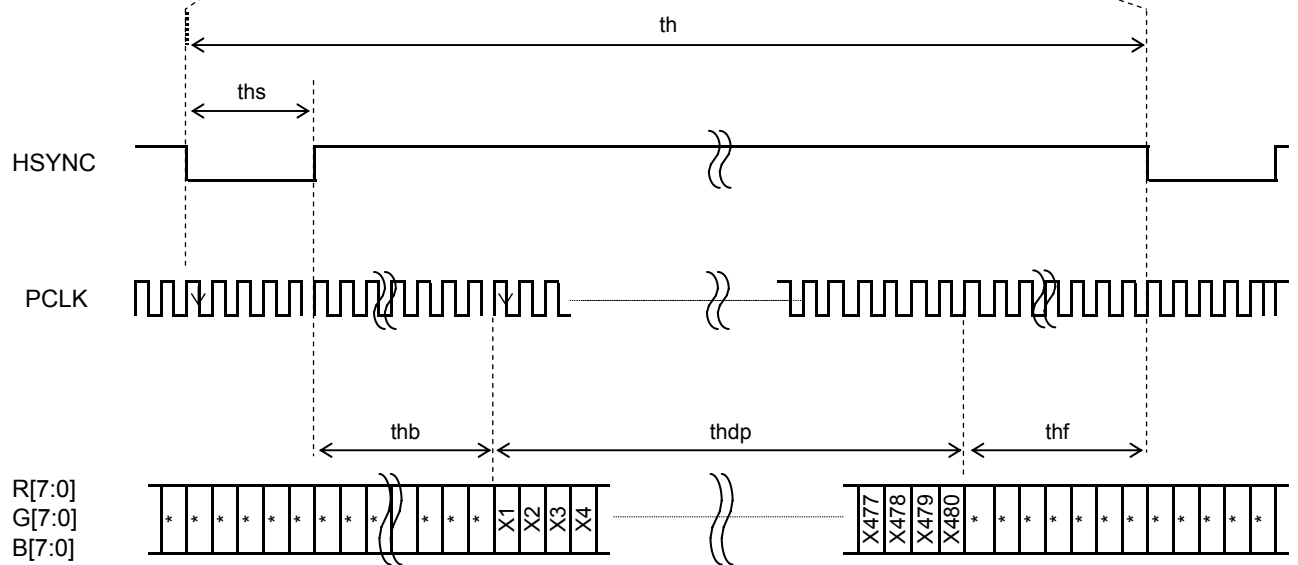

Fig.G Timing Characteristics of input signals

9. About MIPI Interface

9.1 Version

The DSI incorporated in the LCD-Driver complies with the following standards.

MIPI DSI : Version 1.01.00

MIPI D-PHY : Version 1.00.00

Data transfer mode : Video mode only.

9.2 DSI protocol

- Short packets specify the payload length using the Data Type field and are from 2 to 9 bytes in length. Short packets is used for most Command Mode commands and associated parameters.

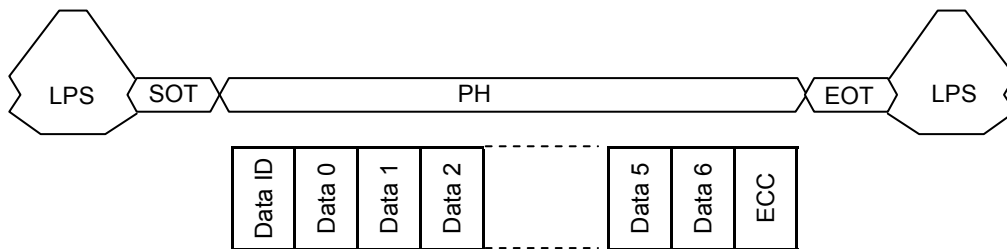

LPS : Low power state

SOT : Start of Transmission

PH : Packet Header

DI(Data ID) : Contain Virtual Channel Identifier and Data Type

ECC : Error Correction Code

- Long packets specify the payload length using a two-byte Word Count field and then the payload maybe 0 to 65,541 bytes in length. Long packets permit transmission of large blocks of pixel or other data.

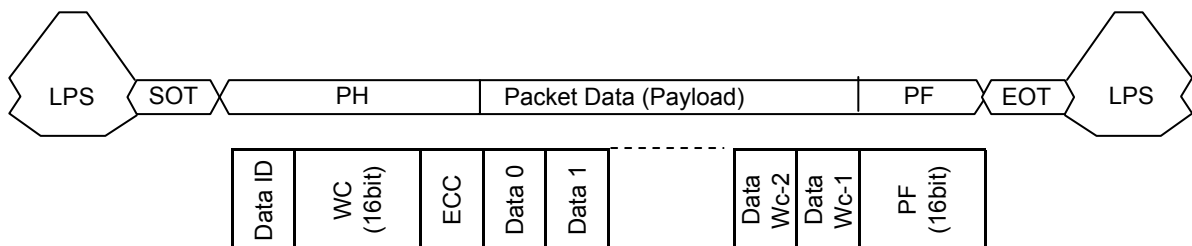

LPS : Low power state

SOT : Start of Transmission

PH : Packet Header

DI(Data ID) : Contain Virtual Channel Identifier and Data Type

WC(Word Count) : The receiver use WC to define packet end.

ECC : Error Correction Code

PF(Packet Footer) : Mean 16-bit Checksum.

9.3 Packet data types

LCD-Driver has the following restriction.

Generic short / Long Write Cmd is not supported.

It is only DCS Short / Long Write Cmd.

Processor to peripheral direction

Data Type Hex	Description	Size
08 h	End of Transmission Packet (08,0F,0F,01)	Short
05 h	DCS WRITE , no parameters	Short
15 h	DCS WRITE , one parameters	Short
06 h	DCS READ , no parameters	Short
37 h	Set Maximum Return Packet Size	Short
09 h	Null Packet , no data	Long
39 h	DCS Long Write Command Packet	Long

Peripheral to processor direction

Data Type Hex	Description	Size
02 h	Acknowledge with Error Report	Short
1C h	DCS Long READ Response	Long
21 h	DCS Read Short Response, 1 byte returned	Short
22 h	DCS Read Short Response, 2 byte returned	Short

9.4 Packet Footer on the long packet

After Packet Data, Packet Footer is added in Long packet. Packet Footer adds CRC calculated from Packet Data as Checksum.

Checksum(2byte) = CRC(Packet Data)

$CRC = X^{16} + X^{12} + X^5 + X^0$

9.5 Instruction List

[Page 0]

Register	DNC	D7	D6	D5	D4	D3	D2	D1	D0
00h	NOP	0	0	0	0	0	0	0	0
01h	Software Reset	0	0	0	0	0	0	0	1
05h	Read Number of the Errors on DSI	0	0	0	0	0	0	1	0
	1st Parameter	-	P[7:0]						
0Ah	Read Display Power Mode	0	0	0	0	0	1	0	1
	1st Parameter	-	BSTON	0	0	SLPOUT	NORON	DISON	0
0Bh	Read Address Mode	0	0	0	0	0	1	0	1
	1st Parameter	-	0	0	0	0	BGR	0	SS
0Ch	Read Pixel Format	0	0	0	0	0	1	1	0
	1st Parameter	-	0	DPI[2:0]		0	0	0	0
0Dh	Read Display Image Mode	0	0	0	0	0	1	1	0
	1st Parameter	-	0	0	INVON	ALLPON	ALLPOFF	GCS[2:0]	
0Eh	Read Display signal Mode	0	0	0	0	0	1	1	1
	1st Parameter	-	TEON	0	HSON	VSON	PCLKON	DEON	0
0Fh	Read Display Self-Diagnostic Result	0	0	0	0	0	1	1	1
	1st Parameter	-	REGLD	FUNDT	0	0	0	0	0
10h	Sleep In	0	0	0	0	1	0	0	0
11h	Sleep Out	0	0	0	0	1	0	0	0
13h	Normal Display Mode On	0	0	0	0	1	0	0	1
20h	Display Inversion Off	0	0	0	1	0	0	0	0
21h	Display Inversion ON	0	0	0	1	0	0	0	0
22h	All Pixel Off	0	0	0	1	0	0	0	1
23h	All Pixel On	0	0	0	1	0	0	0	1
26h	Gamma Curve Set	0	0	0	1	0	0	1	1
	1st Parameter	1	GC[7:0]						
	recommend (01h)		0	0	0	0	0	0	0
28h	Display Off	0	0	0	1	0	1	0	0
29h	Display ON	0	0	0	1	0	1	0	0
34h	Tearing Effect Line OFF	0	0	0	1	1	0	1	0
35h	Tearing Effect Line ON	0	0	0	1	1	0	1	0
36h	Display Access Control	0	0	0	1	1	0	1	1
	1st Parameter	1	0	0	0	0	BGR	0	SS
	recommend (00h)		0	0	0	0	0	0	0
3Ah	Interface Pixel Format	0	0	0	1	1	1	0	1
	1st Parameter	1	0	DPI[2:0]		0	0	0	0
	recommend (60h)		0	1	1	0	0	0	0
51h	Write Display Brightness	0	0	1	0	1	0	0	0
	1st Parameter	1	DBV[7:0]						
	recommend (00h)		0	0	0	0	0	0	0
52h	Read Display Brightness Value	0	0	1	0	1	0	0	1
	1st Parameter	-	DBV[7:0]						
53h	Write CTRL Display	0	0	1	0	1	0	0	1
	1st Parameter	1	0	0	BCTRL	0	DD	BL	0
	recommend (00h)		0	0	0	0	0	0	0
54h	Read CTRL Display	0	0	1	0	1	0	1	0
	1st Parameter	-	0	0	BCTRL	0	DD	BL	0
55h	Write Content Adaptive Brightness	0	0	1	0	1	0	1	0
	1st Parameter	1	C[7:4]			C[3:0]			
	recommend (00h)		0	0	0	0	0	0	0
56h	Read Content Adaptive Brightness	0	0	1	0	1	0	1	1
	1st Parameter	-	C[7:4]			C[3:0]			
5Eh	Write CAB Minimum Brightness	0	0	1	0	1	1	1	1
	1st Parameter	1	CMB[7:0]						
	recommend (00h)		0	0	0	0	0	0	0
5Fh	Read CAB Minimum Brightness	0	0	1	0	1	1	1	1
	1st Parameter	-	CMB[7:0]						
68h	Read Automatic Brightness Control Self-Diagnostic Result Result	0	0	1	1	0	1	0	0
	1st Parameter	-	D[7:6]		0	0	0	0	0

Register		DNC	D7	D6	D5	D4	D3	D2	D1	D0
DAh	Read ID1	0	1	1	0	1	1	0	1	0
	1st Parameter	-	ID1[7:0]							
DBh	Read ID2	0	1	1	0	1	1	0	1	1
	1st Parameter	-	ID2[7:0]							
DCh	Read ID3	0	1	1	0	1	1	1	0	0
	1st Parameter	-	ID3[7:0]							
FEh	Read EXTC Command In SPI	0	1	1	1	1	1	1	1	0
	1st Parameter	1	EXT_S P	EXT_SPI_CNT[6:0]						
	recommend (00h)		0	0	0	0	0	0	0	0
FFh	EXTC Command Set enable register	0	1	1	1	1	1	1	1	1
	1st Parameter	1	1	1	1	1	1	1	1	1
	recommend (FFh)		1	1	1	1	1	1	1	1
	2nd Parameter	1	1	0	0	1	1	0	0	0
	recommend (98h)		1	0	0	1	1	0	0	0
	3rd Parameter	1	0	0	0	0	0	1	1	0
	recommend (06h)		0	0	0	0	0	1	1	0
	4th Parameter	1	0	0	0	0	0	1	0	0
	recommend (04h)		0	0	0	0	0	1	0	0
5th Parameter	1	PAGE[7:0]								
recommend (00h)		0	0	0	0	0	0	0	0	

[Page 1]

Register		DNC	D7	D6	D5	D4	D3	D2	D1	D0
00h	Read ID4	0	0	0	0	0	0	0	0	0
	1st Parameter	-	1	0	0	1	1	0	0	0
01h	Read ID4	0	0	0	0	0	0	0	0	1
	1st Parameter	-	0	0	0	0	0	1	1	0
02h	Read ID4	0	0	0	0	0	0	0	1	0
	1st Parameter	-	0	0	0	0	0	1	0	0
08h	Interface Mode Control 1	0	0	0	0	0	1	0	0	0
	1st Parameter	1	0	0	0	SDO_S TATUS	SEPT_ SDIO	0	0	0
	recommend (18h)		0	0	0	1	1	0	0	0
0Ah	Interface Mode Control 2	0	0	0	0	0	1	0	1	0
	1st Parameter	1	0	0	0	0	0	0	0	2LANE
	recommend (00h)		0	0	0	0	0	0	0	0
20h	Display Function Control 1	0	0	0	1	0	0	0	0	0
	1st Parameter	1	0	0	0	0	0	0	0	SYNC MODE
	recommend (00h)		0	0	0	0	0	0	0	0
21h	Display Function Control 2	0	0	0	1	0	0	0	0	1
	1st Parameter	1	0	0	0	0	VSP_L	HSPL	DPL	EPL
	recommend (01h)		0	0	0	0	0	0	0	1
22h	Set panel operation mode1	0	0	0	1	0	0	0	1	0
	1st Parameter	1	0	0	0	0	BGR_ Panel	0	SS_ Panel	GS_ Panel
	recommend (00h)		0	0	0	0	0	0	0	0
23h	Set panel operation mode2	0	0	0	1	0	0	0	1	1
	1st Parameter	1	0	0	0	0	0	0	REV	0
	recommend (00h)		0	0	0	0	0	0	0	0
24h	Data Complement Setting	0	0	0	1	0	0	1	0	0
	1st Parameter	1	0	0	0	0	0	0	EPF[1 : 0]	
	recommend (03h)		0	0	0	0	0	0	1	1
25h	Blanking Porch 1	0	0	0	1	0	0	1	0	1
	1st Parameter	1	0	VFP[6:0]						
	recommend (04h)		0	0	0	0	0	1	0	0
26h	Blanking Porch 2	0	0	0	1	0	0	1	1	0
	1st Parameter	1	0	VBP[6:0]						
	recommend (14h)		0	0	0	1	0	1	0	0
27h	Blanking Porch 3	0	0	0	1	0	0	1	1	1
	1st Parameter	1	HBP[7:0]							
	recommend (0Fh)		0	0	0	0	1	1	1	1

Register	DNC	D7	D6	D5	D4	D3	D2	D1	D0
28h	Blanking Porch 4	0	0	0	1	0	1	0	0
	1st Parameter	1	0	0	0	0	0	HBP[9:8]	
	recommend (00h)		0	0	0	0	0	0	0
30h	Resolution Control	0	0	0	1	1	0	0	0
	1st Parameter	1	0	0	0	0	0	RES[2:0]	
	recommend (03h)		0	0	0	0	0	0	1
31h	Display Inversion Control	0	0	0	1	1	0	0	1
	1st Parameter	1	0	0	0	0	NLA[3:0]		
	recommend (00h)		0	0	0	0	0	0	0
34h	Dithering Enable	0	0	0	1	1	0	1	0
	1st Parameter	1	0	0	0	0	0	0	Dith_en
	recommend (00h)		0	0	0	0	0	0	0
35h	Source Signal Adjust	0	0	0	1	1	0	1	0
	1st Parameter	1	0	0	0	0	CHOPPER SEL_REG[2:0]		
	recommend (06h)		0	0	0	0	0	1	1
40h	Power Control 1	0	0	1	0	0	0	0	0
	1st Parameter	1	EXB1T	0	EXT_CPCK_SE L		BT[3:0]		
	recommend (30h)		0	0	1	1	0	0	0
41h	Power Control 2	0	0	1	0	0	0	0	1
	1st Parameter	1	0	DDVDH_CLP[2:0]		0	DDVDL_CLP[2:0]		
	recommend (44h)		0	1	0	0	0	1	0
42h	Power Control 3	0	0	1	0	0	0	0	1
	1st Parameter	1	0	0	VGH_CP[1:0]		0	VGL_CP[1:0]	
	recommend (00h)		0	0	0	0	0	0	0
43h	Power Control 4	0	0	1	0	0	0	0	1
	1st Parameter	1	VGH_ CLP EN	0	0	0	VGH_CLP[3:0]		
	recommend (89h)		1	0	0	0	1	0	0
44h	Power Control 5	0	0	1	0	0	0	1	0
	1st Parameter	1	VGL_ CLP EN	0	0	0	VGL_CLP[3:0]		
	recommend (8Eh)		1	0	0	0	1	1	1
45h	Power Control 6	0	0	1	0	0	0	1	0
	1st Parameter	1	VGH_REG[3:0]			VGL_REG[3:0]			
	recommend (D9h)		1	1	0	1	1	0	0
46h	Power Control 7	0	0	1	0	0	0	1	1
	1st Parameter	1	0	DDVDH_PK1[2:0]		0	DDVDL_PK2[2:0]		
	recommend (33h)		0	0	1	1	0	0	1
47h	Power Control 8	0	0	1	0	0	0	1	1
	1st Parameter	1	0	VCL_PK3[2:0]		0	VGHL_PK4[2:0]		
	recommend (33h)		0	0	1	1	0	0	1
50h	Power Control 9	0	0	1	0	1	0	0	0
	1st Parameter	1	VREG1[7:0]						
	recommend (90h)		1	0	0	1	0	0	0
51h	Power Control 10	0	0	1	0	1	0	0	1
	1st Parameter	1	VREG2[7:0]						
	recommend (90h)		1	0	0	1	0	0	0
52h	VCOM Control 1	0	0	1	0	1	0	0	1
	1st Parameter	1	0	0	0	0	0	0	VCM1[8]
	recommend (00h)		0	0	0	0	0	0	0
53h	VCOM Control 2	0	0	1	0	1	0	0	1
	1st Parameter	1	VCM1[7:0]						
	recommend (30h)		0	0	1	1	0	0	0
54h	VCOM Control 3	0	0	1	0	1	0	1	0
	1st Parameter	1	0	0	0	0	0	0	VCM2[8]
	recommend (00h)		0	0	0	0	0	0	0
55h	VCOM Control 4	0	0	1	0	1	0	1	0
	1st Parameter	1	VCM2[7:0]						
	recommend (30h)		0	0	1	1	0	0	0
56h	VCOM Control 5	0	0	1	0	1	0	1	1
	1st Parameter	1	0	0	0	NVM2	0	0	NVM1
	recommend (00h)		0	0	0	0	0	0	0

Register	DNC	D7	D6	D5	D4	D3	D2	D1	D0	
57h	Low Voltage Detection	0	0	1	0	1	0	1	1	1
	1st Parameter	1	0	VDET[2:0]		0	VCORE_VD[2:0]			
	recommend (20h)		0	0	1	0	0	0	0	0
58h	Entry Mode Set	0	0	1	0	1	1	0	0	0
	1st Parameter	1	LVD	0	0	1	0	0	0	DSTB
	recommend (90h)		1	0	0	1	0	0	0	0
60h	Source Timing Adjustment 1	0	0	1	1	0	0	0	0	0
	1st Parameter	1	SDT[7:0]							
	recommend (0Dh)		0	0	0	0	1	1	0	1
61h	Source Timing Adjustment 2	0	0	1	1	0	0	0	0	1
	1st Parameter	1	CRT[7:0]							
	recommend (08h)		0	0	0	0	1	0	0	0
62h	Source Timing Adjustment 3	0	0	1	1	0	0	0	1	0
	1st Parameter	1	EQT[7:0]							
	recommend (08h)		0	0	0	0	1	0	0	0
63h	Source Timing Adjustment 4	0	0	1	1	0	0	0	1	1
	1st Parameter	1	0	0	PCT[5:0]					
	recommend (09h)		0	0	0	0	1	0	0	1
80h	Synchronization Timing Adjust 1	0	1	0	0	0	0	0	0	0
	1st Parameter	1	TOUCH_OPT[1:	VSOD[1:0]		HOSM[1:0]		HS_OPT		
	recommend (00h)		0	0	0	0	0	0	0	0
81h	Synchronization Timing Adjust 2	0	1	0	0	0	0	0	0	1
	1st Parameter	1	0	HSOD[6:0]						
	recommend (05h)		0	0	0	0	0	1	0	1
82h	Synchronization Timing Adjust 3	0	1	0	0	0	0	0	1	0
	1st Parameter	1	HSOHW[7:0]							
	recommend (19h)		0	0	0	1	1	0	0	1
A0h	Positive Gamma Correction 1	0	1	0	1	0	0	0	0	0
	1st Parameter	1	0	0	VP0[5:0]					
	recommend (00h)		0	0	0	0	0	0	0	0
A1h	Positive Gamma Correction 2	0	1	0	1	0	0	0	0	1
	1st Parameter	1	0	0	VP4[5:0]					
	recommend (0Ch)		0	0	0	0	1	1	0	0
A2h	Positive Gamma Correction 3	0	1	0	1	0	0	0	1	0
	1st Parameter	1	0	0	VP8[5:0]					
	recommend (13h)		0	0	0	1	0	0	1	1
A3h	Positive Gamma Correction 4	0	1	0	1	0	0	0	1	1
	1st Parameter	1	0	0	VP16[4:0]					
	recommend (0Fh)		0	0	0	0	1	1	1	1
A4h	Positive Gamma Correction 5	0	1	0	1	0	0	1	0	0
	1st Parameter	1	0	0	VP32[4:0]					
	recommend (0Ah)		0	0	0	0	1	0	1	0
A5h	Positive Gamma Correction 6	0	1	0	1	0	0	1	0	1
	1st Parameter	1	0	0	VP52[4:0]					
	recommend (0Dh)		0	0	0	0	1	1	0	1
A6h	Positive Gamma Correction 7	0	1	0	1	0	0	1	1	0
	1st Parameter	1	0	0	VP80[3:0]					
	recommend (0Ch)		0	0	0	0	1	1	0	0
A7h	Positive Gamma Correction 8	0	1	0	1	0	0	1	1	1
	1st Parameter	1	0	0	VP108[3:0]					
	recommend (0Bh)		0	0	0	0	1	0	1	1
A8h	Positive Gamma Correction 9	0	1	0	1	0	1	0	0	0
	1st Parameter	1	0	0	VP147[3:0]					
	recommend (01h)		0	0	0	0	0	0	0	1
A9h	Positive Gamma Correction 10	0	1	0	1	0	1	0	0	1
	1st Parameter	1	0	0	VP175[3:0]					
	recommend (06h)		0	0	0	0	0	1	1	0
AAh	Positive Gamma Correction 11	0	1	0	1	0	1	0	1	0
	1st Parameter	1	0	0	VP203[4:0]					
	recommend (15h)		0	0	0	1	0	1	0	1
ABh	Positive Gamma Correction 12	0	1	0	1	0	1	0	1	1
	1st Parameter	1	0	0	VP231[4:0]					
	recommend (07h)		0	0	0	0	0	1	1	1

Register		DNC	D7	D6	D5	D4	D3	D2	D1	D0
ACh	Positive Gamma Correction 13	0	1	0	1	0	1	1	0	0
	1st Parameter	1	0	0	0	VP239[4:0]				
	recommend (12h)		0	0	0	1	0	0	1	0
ADh	Positive Gamma Correction 14	0	1	0	1	0	1	1	0	1
	1st Parameter	1	0	0	VP247[5:0]					
	recommend (28h)		0	0	1	0	1	0	0	0
AEh	Positive Gamma Correction 15	0	1	0	1	0	1	1	1	0
	1st Parameter	1	0	0	VP251[5:0]					
	recommend (20h)		0	0	1	0	0	0	0	0
AFh	Positive Gamma Correction 16	0	1	0	1	0	1	1	1	1
	1st Parameter	1	0	0	VP255[5:0]					
	recommend (14h)		0	0	0	1	0	1	0	0
C0h	Negative Gamma Correction	0	1	1	0	0	0	0	0	0
	1st Parameter	1	0	0	VN0[5:0]					
	recommend (00h)		0	0	0	0	0	0	0	0
C1h	Negative Gamma Correction 2	0	1	1	0	0	0	0	0	1
	1st Parameter	1	0	0	VN4[5:0]					
	recommend (0Ch)		0	0	0	0	1	1	0	0
C2h	Negative Gamma Correction 3	0	1	1	0	0	0	0	1	0
	1st Parameter	1	0	0	VN8[5:0]					
	recommend (13h)		0	0	0	1	0	0	1	1
C3h	Negative Gamma Correction 4	0	1	1	0	0	0	0	1	1
	1st Parameter	1	0	0	VN16[4:0]					
	recommend (0Fh)		0	0	0	0	1	1	1	1
C4h	Negative Gamma Correction 5	0	1	1	0	0	0	1	0	0
	1st Parameter	1	0	0	VN32[4:0]					
	recommend (09h)		0	0	0	0	1	0	0	1
C5h	Negative Gamma Correction 6	0	1	1	0	0	0	1	0	1
	1st Parameter	1	0	0	VN52[4:0]					
	recommend (0Dh)		0	0	0	0	1	1	0	1
C6h	Negative Gamma Correction 7	0	1	1	0	0	0	1	1	0
	1st Parameter	1	0	0	VN80[3:0]					
	recommend (0Ch)		0	0	0	0	1	1	0	0
C7h	Negative Gamma Correction 8	0	1	1	0	0	0	1	1	1
	1st Parameter	1	0	0	VN108[3:0]					
	recommend (0Bh)		0	0	0	0	1	0	1	1
C8h	Negative Gamma Correction 9	0	1	1	0	0	1	0	0	0
	1st Parameter	1	0	0	VN147[3:0]					
	recommend (01h)		0	0	0	0	0	0	0	1
C9h	Negative Gamma Correction 10	0	1	1	0	0	1	0	0	1
	1st Parameter	1	0	0	VN175[3:0]					
	recommend (06h)		0	0	0	0	0	1	1	0
CAh	Negative Gamma Correction 11	0	1	1	0	0	1	0	1	0
	1st Parameter	1	0	0	VN203[4:0]					
	recommend (14h)		0	0	0	1	0	1	0	0
CBh	Negative Gamma Correction 12	0	1	1	0	0	1	0	1	1
	1st Parameter	1	0	0	VN231[4:0]					
	recommend (07h)		0	0	0	0	0	1	1	1
CCh	Negative Gamma Correction 13	0	1	1	0	0	1	1	0	0
	1st Parameter	1	0	0	VN239[4:0]					
	recommend (0Fh)		0	0	0	0	1	1	1	1
CDh	Negative Gamma Correction 14	0	1	1	0	0	1	1	0	1
	1st Parameter	1	0	0	VN247[5:0]					
	recommend (21h)		0	0	1	0	0	0	0	1
CEh	Negative Gamma Correction 15	0	1	1	0	0	1	1	1	0
	1st Parameter	1	0	0	VN251[5:0]					
	recommend (17h)		0	0	0	1	0	1	1	1
CFh	Negative Gamma Correction 16	0	1	1	0	0	1	1	1	1
	1st Parameter	1	0	0	VN255[5:0]					
	recommend (0Ah)		0	0	0	0	1	0	1	0

Register		DNC	D7	D6	D5	D4	D3	D2	D1	D0
E0h	NV Memory Write 1	0	1	1	1	0	0	0	0	0
	1st Parameter	1	PGM_DATA[7:0]							
	recommend (00h)		0	0	0	0	0	0	0	0
E1h	NV Memory Write 2	0	1	1	1	0	0	0	0	1
	1st Parameter	1	PGM_ADR[7:0] / NVM_READ_ADR[7:0]							
	recommend (03h)		0	0	0	0	0	0	1	1
E3h	NV Memory Protection Key 1	0	1	1	1	0	0	0	1	1
	1st Parameter	1	KEY[23:16]							
	recommend (55h)		0	1	0	1	0	1	0	1
E4h	NV Memory Protection Key 1	0	1	1	1	0	0	1	0	0
	1st Parameter	1	KEY[15:8]							
	recommend (AAh)		1	0	1	0	1	0	1	0
E5h	NV Memory Protection Key 1	0	1	1	1	0	0	1	0	1
	1st Parameter	1	KEY[7:0]							
	recommend (66h)		0	1	1	0	0	1	1	0
E6h	NV Memory Status Read 1	0	1	1	1	0	0	1	1	0
	1st Parameter	1	0	ID2_Mk[2:0]			0	ID1_Mk[2:0]		
E7h	NV Memory Status Read 2	0	1	1	1	0	0	1	1	1
	1st Parameter	1	0	0	0	0	ID3_Mk[2:0]			
E8h	NV Memory Status Read 3	0	1	1	1	0	1	0	0	0
	1st Parameter	1	GMAP_MK	GMAN_MK	VCM2_Mk[2:0]			VCM1_Mk[2:0]		
	recommend (00h)									
E9h	NV Memory Status Read 4	0	1	1	1	0	1	0	0	1
	1st Parameter	1	OTP	0	0	0	0	0	0	0
EAh	NV Memory Status Read 5	0	1	1	1	0	1	0	1	0
	1st Parameter	1	NVM_READ_DATA[7:0]							

[Page 2]

Register		DNC	D7	D6	D5	D4	D3	D2	D1	D0
00h	Digital Gamma Control 1	0	0	0	0	0	0	0	0	0
	1st Parameter	1	RCA0[3:0]			BCA0[3:0]				
	recommend (00h)									
⋮										
3Fh	Digital Gamma Control 1	0	0	0	1	1	1	1	1	1
	1st Parameter	1	RCA63[3:0]				BCA63[3:0]			
	recommend (00h)									
40h	Digital 3 Gamma Enable	0	0	1	0	0	0	0	0	0
	1st Parameter	1	0	0	0	0	0	0	0	EN_3G
	recommend (00h)		0	0	0	0	0	0	0	0

[Page 3]

Register		DNC	D7	D6	D5	D4	D3	D2	D1	D0
00h	Digital Gamma Control 2	0	0	0	0	0	0	0	0	0
	1st Parameter	1	RFA0[3:0]			BFA0[3:0]				
	recommend (00h)									
⋮										
7Fh	Digital Gamma Control 2	0	0	1	1	1	1	1	1	1
	1st Parameter	1	RFA127[3:0]				BFA127[3:0]			
	recommend (00h)									

[Page 4]

Register		DNC	D7	D6	D5	D4	D3	D2	D1	D0
00h	Digital Gamma Control 3	0	0	0	0	0	0	0	0	0
	1st Parameter	1	RFA128[3:0]			BFA128[3:0]				
	recommend (00h)									
⋮										
7Fh	Digital Gamma Control 3	0	0	1	1	1	1	1	1	1
	1st Parameter	1	RFA255[3:0]				BFA255[3:0]			
	recommend (00h)									

[Page 5]

Register	DNC	D7	D6	D5	D4	D3	D2	D1	D0	
00h	Backlight Control 1	0	0	0	0	0	0	0	0	
	1st Parameter	1	PWM_DIV[7:0]							
	recommend (E8h)		1	1	1	0	1	0	0	
01h	Backlight Control 2	0	0	0	0	0	0	0	1	
	1st Parameter	1	THRES_MOV[3:0]			THRES_STILL[3:0]				
	recommend (BBh)		1	0	1	1	1	0	1	
02h	Backlight Control 3	0	0	0	0	0	0	1	0	
	1st Parameter	1	0	0	0	0	THRES_UI[3:0]			
	recommend (0Bh)		0	0	0	0	1	0	1	
03h	Backlight Control 4	0	0	0	0	0	0	1	1	
	1st Parameter	1	DTH_MOV[3:0]			DTH_STILL[3:0]				
	recommend (A8h)		1	0	1	0	1	0	0	
04h	Backlight Control 5	0	0	0	0	0	0	1	0	
	1st Parameter	1	0	0	0	0	DTH_UI[3:0]			
	recommend (04h)		0	0	0	0	0	1	0	
05h	Backlight Control 6	0	0	0	0	0	0	1	1	
	1st Parameter	1	0	DIM_MOV[2:0]		0	DIM_STILL[2:0]			
	recommend (43h)		0	1	0	0	0	0	1	
06h	Backlight Control 7	0	0	0	0	0	0	1	0	
	1st Parameter	1	DIM_MIN[3:0]			0	DIM_UI[2:0]			
	recommend (02h)		0	0	0	0	0	0	1	
07h	Backlight Control 8	0	0	0	0	0	0	1	1	
	1st Parameter	1	LABC_SRE_THR[3:0]			LABC_SRE_ENABLE	LED_ONR	LEDON_POL	PWM_POL	
	recommend (B0h)		1	0	1	1	0	0	0	
08h	Backlight Control 9	0	0	0	0	0	1	0	0	
	1st Parameter	1	SREABC_BOOSTEN	1	1	1	SREABC_EN	1	0	
	recommend (74h)		0	1	1	1	0	1	0	
09h	Backlight Control 10	0	0	0	0	0	1	0	1	
	1st Parameter	1	ALS8BIT[7:0]							
	recommend (90h)		1	0	0	1	0	0	0	
25h	Color Enhancement Control 1	0	0	0	1	0	0	1	1	
	1st Parameter	1	0	0	0	FIRST_AXIS_1[4:0]				
	recommend (00h)		0	0	0	0	0	0	0	
26h	Color Enhancement Control 2	0	0	0	1	0	0	1	0	
	1st Parameter	1	0	0	0	FIRST_AXIS_2[4:0]				
	recommend (00h)		0	0	0	0	0	0	0	
27h	Color Enhancement Control 3	0	0	0	1	0	0	1	1	
	1st Parameter	1	0	0	0	FIRST_AXIS_3[4:0]				
	recommend (00h)		0	0	0	0	0	0	0	
28h	Color Enhancement Control 4	0	0	0	1	0	1	0	0	
	1st Parameter	1	0	0	0	FIRST_AXIS_4[4:0]				
	recommend (00h)		0	0	0	0	0	0	0	
29h	Color Enhancement Control 5	0	0	0	1	0	1	0	1	
	1st Parameter	1	0	0	0	SECOND_AXIS_1[4:0]				
	recommend (00h)		0	0	0	0	0	0	0	
2Ah	Color Enhancement Control 6	0	0	0	1	0	1	0	0	
	1st Parameter	1	0	0	0	SECOND_AXIS_2[4:0]				
	recommend (00h)		0	0	0	0	0	0	0	
2Bh	Color Enhancement Control 7	0	0	0	1	0	1	0	1	
	1st Parameter	1	0	0	0	SECOND_AXIS_3[4:0]				
	recommend (00h)		0	0	0	0	0	0	0	
2Ch	Color Enhancement Control 8	0	0	0	1	0	1	1	0	
	1st Parameter	1	0	0	0	SECOND_AXIS_4[4:0]				
	recommend (00h)		0	0	0	0	0	0	0	
2Dh	Color Enhancement Control 9	0	0	0	1	0	1	1	1	
	1st Parameter	1	0	0	0	THIRD_AXIS_1[4:0]				
	recommend (00h)		0	0	0	0	0	0	0	
2Eh	Color Enhancement Control 10	0	0	0	1	0	1	1	0	
	1st Parameter	1	0	0	0	THIRD_AXIS_2[4:0]				
	recommend (00h)		0	0	0	0	0	0	0	

Register		DNC	D7	D6	D5	D4	D3	D2	D1	D0
2Fh	Color Enhancement Control 11	0	0	0	1	0	1	1	1	1
	1st Parameter	1	0	0	0	THIRD_AXIS_3[4:0]				
	recommend (00h)		0	0	0	0	0	0	0	0
30h	Color Enhancement Control 12	0	0	0	1	1	0	0	0	0
	1st Parameter	1	0	0	0	THIRD_AXIS_4[4:0]				
	recommend (00h)		0	0	0	0	0	0	0	0
31h	Color Enhancement Control 13	0	0	0	1	1	0	0	0	1
	1st Parameter	1	0	0	0	FOURTH_AXIS_1[4:0]				
	recommend (00h)		0	0	0	0	0	0	0	0
32h	Color Enhancement Control 14	0	0	0	1	1	0	0	1	0
	1st Parameter	1	0	0	0	FOURTH_AXIS_2[4:0]				
	recommend (00h)		0	0	0	0	0	0	0	0
33h	Color Enhancement Control 15	0	0	0	1	1	0	0	1	1
	1st Parameter	1	0	0	0	FOURTH_AXIS_3[4:0]				
	recommend (00h)		0	0	0	0	0	0	0	0
34h	Color Enhancement Control 16	0	0	0	1	1	0	1	0	0
	1st Parameter	1	0	0	0	FOURTH_AXIS_4[4:0]				
	recommend (00h)		0	0	0	0	0	0	0	0
35h	Color Enhancement Control 17	0	0	0	1	1	0	1	0	1
	1st Parameter	1	0	0	0	FIFTH_AXIS_1[4:0]				
	recommend (00h)		0	0	0	0	0	0	0	0
36h	Color Enhancement Control 18	0	0	0	1	1	0	1	1	0
	1st Parameter	1	0	0	0	FIFTH_AXIS_2[4:0]				
	recommend (00h)		0	0	0	0	0	0	0	0
37h	Color Enhancement Control 19	0	0	0	1	1	0	1	1	1
	1st Parameter	1	0	0	0	FIFTH_AXIS_3[4:0]				
	recommend (00h)		0	0	0	0	0	0	0	0
38h	Color Enhancement Control 20	0	0	0	1	1	1	0	0	0
	1st Parameter	1	0	0	0	FIFTH_AXIS_4[4:0]				
	recommend (00h)		0	0	0	0	0	0	0	0
39h	Color Enhancement Control 21	0	0	0	1	1	1	0	0	1
	1st Parameter	1	0	0	0	SIXTH_AXIS_1[4:0]				
	recommend (00h)		0	0	0	0	0	0	0	0
3Ah	Color Enhancement Control 22	0	0	0	1	1	1	0	1	0
	1st Parameter	1	0	0	0	SIXTH_AXIS_2[4:0]				
	recommend (00h)		0	0	0	0	0	0	0	0
3Bh	Color Enhancement Control 23	0	0	0	1	1	1	0	1	1
	1st Parameter	1	0	0	0	SIXTH_AXIS_3[4:0]				
	recommend (00h)		0	0	0	0	0	0	0	0
3Ch	Color Enhancement Control 24	0	0	0	1	1	1	1	0	0
	1st Parameter	1	0	0	0	SIXTH_AXIS_4[4:0]				
	recommend (00h)		0	0	0	0	0	0	0	0

[Page 6]

Register		DNC	D7	D6	D5	D4	D3	D2	D1	D0
00h	GIP Control 1	0	0	0	0	0	0	0	0	0
	1st Parameter	1	STV_A_Rise[10:8]			GIP_0_SET0				
	recommend (20h)		0	0	1	0	0	0	0	0
01h	GIP Control 1	0	0	0	0	0	0	0	0	1
	1st Parameter	1	STV_A_Rise[7:0]							
	recommend (02h)		0	0	0	0	0	0	1	0
02h	GIP Control 1	0	0	0	0	0	0	0	1	0
	1st Parameter	1	GIP_0_SET1							
	recommend (00h)		0	0	0	0	0	0	0	0
03h	GIP Control 1	0	0	0	0	0	0	0	1	1
	1st Parameter	1	GIP_0_SET2							
	recommend (02h)		0	0	0	0	0	0	1	0
04h	GIP Control 1	0	0	0	0	0	0	1	0	0
	1st Parameter	1	GIP_0_SET3							
	recommend (01h)		0	0	0	0	0	0	0	1
05h	GIP Control 1	0	0	0	0	0	0	1	0	1
	1st Parameter	1	GIP_0_SET4							
	recommend (01h)		0	0	0	0	0	0	0	1

Register		DNC	D7	D6	D5	D4	D3	D2	D1	D0
06h	GIP Control 1	0	0	0	0	0	0	1	1	0
	1st Parameter	1	CLK_A_Rise[10:8]			GIP_0_SET5				
	recommend (88h)		1	0	0	0	1	0	0	0
07h	GIP Control 1	0	0	0	0	0	0	1	1	1
	1st Parameter	1	CLK_A_Rise[7:0]							
	recommend (00h)		0	0	0	0	0	0	0	0
08h	GIP Control 1	0	0	0	0	0	1	0	0	0
	1st Parameter	1	GIP_0_SET6							
	recommend (01h)		0	0	0	0	0	0	0	1
09h	GIP Control 1	0	0	0	0	0	1	0	0	1
	1st Parameter	1	GIP_0_SET7							
	recommend (80h)		1	0	0	0	0	0	0	0
0Ah	GIP Control 1	0	0	0	0	0	1	0	1	0
	1st Parameter	1	GIP_0_SET8							
	recommend (00h)		0	0	0	0	0	0	0	0
0Bh	GIP Control 1	0	0	0	0	0	1	0	1	1
	1st Parameter	1	GIP_0_SET9							
	recommend (00h)		0	0	0	0	0	0	0	0
0Ch	GIP Control 1	0	0	0	0	0	1	1	0	0
	1st Parameter	1	GIP_0_SET10							
	recommend (01h)		0	0	0	0	0	0	0	1
0Dh	GIP Control 1	0	0	0	0	0	1	1	0	1
	1st Parameter	1	GIP_0_SET11							
	recommend (01h)		0	0	0	0	0	0	0	1
0Eh	GIP Control 1	0	0	0	0	0	1	1	1	0
	1st Parameter	1	GIP_0_SET12							
	recommend (00h)		0	0	0	0	0	0	0	0
0Fh	GIP Control 1	0	0	0	0	0	1	1	1	1
	1st Parameter	1	GIP_0_SET13							
	recommend (00h)		0	0	0	0	0	0	0	0
10h	GIP Control 1	0	0	0	0	1	0	0	0	0
	1st Parameter	1	GIP_0_SET14							
	recommend (55h)		0	1	0	1	0	1	0	1
11h	GIP Control 1	0	0	0	0	1	0	0	0	1
	1st Parameter	1	GIP_0_SET15							
	recommend (50h)		0	1	0	1	0	0	0	0
12h	GIP Control 1	0	0	0	0	1	0	0	1	0
	1st Parameter	1	GIP_0_SET16							
	recommend (01h)		0	0	0	0	0	0	0	1
13h	GIP Control 1	0	0	0	0	1	0	0	1	1
	1st Parameter	1	GIP_0_SET17							
	recommend (00h)		0	0	0	0	0	0	0	0
14h	GIP Control 1	0	0	0	0	1	0	1	0	0
	1st Parameter	1	GIP_0_SET18							
	recommend (00h)		0	0	0	0	0	0	0	0
15h	GIP Control 1	0	0	0	0	1	0	1	0	1
	1st Parameter	1	GIP_0_SET19							
	recommend (43h)		0	1	0	0	0	0	1	1
16h	GIP Control 1	0	0	0	0	1	0	1	1	0
	1st Parameter	1	GIP_0_SET20							
	recommend (0Bh)		0	0	0	0	1	0	1	1
17h	GIP Control 1	0	0	0	0	1	0	1	1	1
	1st Parameter	1	GIP_0_SET21							
	recommend (00h)		0	0	0	0	0	0	0	0
18h	GIP Control 1	0	0	0	0	1	1	0	0	0
	1st Parameter	1	GIP_0_SET22							
	recommend (00h)		0	0	0	0	0	0	0	0
19h	GIP Control 1	0	0	0	0	1	1	0	0	1
	1st Parameter	1	GIP_0_SET23							
	recommend (00h)		0	0	0	0	0	0	0	0
1Ah	GIP Control 1	0	0	0	0	1	1	0	1	0
	1st Parameter	1	GIP_0_SET24							
	recommend (00h)		0	0	0	0	0	0	0	0

Register		DNC	D7	D6	D5	D4	D3	D2	D1	D0
1Bh	GIP Control 1	0	0	0	0	1	1	0	1	1
	1st Parameter	1	GIP_0_SET25							
	recommend (00h)		0	0	0	0	0	0	0	0
1Ch	GIP Control 1	0	0	0	0	1	1	1	0	0
	1st Parameter	1	GIP_0_SET26							
	recommend (00h)		0	0	0	0	0	0	0	0
1Dh	GIP Control 1	0	0	0	0	1	1	1	0	1
	1st Parameter	1	GIP_0_SET27							
	recommend (00h)		0	0	0	0	0	0	0	0
20h	GIP Control 2	0	0	0	1	0	0	0	0	0
	1st Parameter	1	GIP_1_SET0							
	recommend (01h)		0	0	0	0	0	0	0	1
21h	GIP Control 2	0	0	0	1	0	0	0	0	1
	1st Parameter	1	GIP_1_SET1							
	recommend (23h)		0	0	1	0	0	0	1	1
22h	GIP Control 2	0	0	0	1	0	0	0	1	0
	1st Parameter	1	GIP_1_SET2							
	recommend (45h)		0	1	0	0	0	1	0	1
23h	GIP Control 2	0	0	0	1	0	0	0	1	1
	1st Parameter	1	GIP_1_SET3							
	recommend (67h)		0	1	1	0	0	1	1	1
24h	GIP Control 2	0	0	0	1	0	0	1	0	0
	1st Parameter	1	GIP_1_SET4							
	recommend (01h)		0	0	0	0	0	0	0	1
25h	GIP Control 2	0	0	0	1	0	0	1	0	1
	1st Parameter	1	GIP_1_SET5							
	recommend (23h)		0	0	1	0	0	0	1	1
26h	GIP Control 2	0	0	0	1	0	0	1	1	0
	1st Parameter	1	GIP_1_SET6							
	recommend (45h)		0	1	0	0	0	1	0	1
27h	GIP Control 2	0	0	0	1	0	0	1	1	1
	1st Parameter	1	GIP_1_SET7							
	recommend (67h)		0	1	1	0	0	1	1	1
30h	GIP Control 3	0	0	0	1	1	0	0	0	0
	1st Parameter	1	GIP_2_SET0							
	recommend (02h)		0	0	0	0	0	0	1	0
31h	GIP Control 3	0	0	0	1	1	0	0	0	1
	1st Parameter	1	GIP_2_SET1							
	recommend (22h)		0	0	1	0	0	0	1	0
32h	GIP Control 3	0	0	0	1	1	0	0	1	0
	1st Parameter	1	GIP_2_SET2							
	recommend (22h)		0	0	1	0	0	0	1	0
33h	GIP Control 3	0	0	0	1	1	0	0	1	1
	1st Parameter	1	GIP_2_SET3							
	recommend (88h)		1	0	0	0	1	0	0	0
34h	GIP Control 3	0	0	0	1	1	0	1	0	0
	1st Parameter	1	GIP_2_SET4							
	recommend (AAh)		1	0	1	0	1	0	1	0
35h	GIP Control 3	0	0	0	1	1	0	1	0	1
	1st Parameter	1	GIP_2_SET5							
	recommend (BBh)		1	0	1	1	1	0	1	1
36h	GIP Control 3	0	0	0	1	1	0	1	1	0
	1st Parameter	1	GIP_2_SET6							
	recommend (66h)		0	1	1	0	0	1	1	0
37h	GIP Control 3	0	0	0	1	1	0	1	1	1
	1st Parameter	1	GIP_2_SET7							
	recommend (22h)		0	0	1	0	0	0	1	0
38h	GIP Control 3	0	0	0	1	1	1	0	0	0
	1st Parameter	1	GIP_2_SET8							
	recommend (22h)		0	0	1	0	0	0	1	0
39h	GIP Control 3	0	0	0	1	1	1	0	0	1
	1st Parameter	1	GIP_2_SET9							
	recommend (22h)		0	0	1	0	0	0	1	0

Register		DNC	D7	D6	D5	D4	D3	D2	D1	D0
3Ah	GIP Control 3	0	0	0	1	1	1	0	1	0
	1st Parameter	1	GIP_2_SET10							
	recommend (22h)		0	0	1	0	0	0	1	0
3Bh	GIP Control 3	0	0	0	1	1	1	0	1	1
	1st Parameter	1	GIP_2_SET11							
	recommend (22h)		0	0	1	0	0	0	1	0
3Ch	GIP Control 3	0	0	0	1	1	1	1	0	0
	1st Parameter	1	GIP_2_SET12							
	recommend (22h)		0	0	1	0	0	0	1	0
3Dh	GIP Control 3	0	0	0	1	1	1	1	0	1
	1st Parameter	1	GIP_2_SET13							
	recommend (22h)		0	0	1	0	0	0	1	0
3Eh	GIP Control 3	0	0	0	1	1	1	1	1	0
	1st Parameter	1	GIP_2_SET14							
	recommend (22h)		0	0	1	0	0	0	1	0
3Fh	GIP Control 3	0	0	0	1	1	1	1	1	1
	1st Parameter	1	GIP_2_SET15							
	recommend (22h)		0	0	1	0	0	0	1	0
40h	GIP Control 3	0	0	1	0	0	0	0	0	0
	1st Parameter	1	GIP_2_SET16							
	recommend (22h)		0	0	1	0	0	0	1	0
53h	GOUT_VGLO Control	0	0	1	0	1	0	0	1	1
	1st Parameter	1	0	0	0	1	GOUT_VGLO[3:0]			
	recommend (12h)		0	0	0	1	0	0	1	0
54h	GOUT_VGHO Control	0	0	1	0	1	0	1	0	0
	1st Parameter	1	0	GOUT_VGHO[2:0]			0	0	0	1
	recommend (11h)		0	0	0	1	0	0	0	1

[Page 7]

Register		DNC	D7	D6	D5	D4	D3	D2	D1	D0
06h	VCL Control	0	0	0	0	0	0	1	1	0
	1st Parameter	1	0	0	0	VCLOPT	0	0	VCL_CLP[1:0]	
	recommend (00h)		0	0	0	0	0	0	0	0
17h	VGL_REG EN	0	0	0	0	1	0	1	1	1
	1st Parameter	1	0	0	1	VGLRE G	0	0	1	0
	recommend (32h)		0	0	1	1	0	0	1	0
18h	VREG1/2OUT ENABLE	0	0	0	0	1	1	0	0	0
	1st Parameter	1	0	0	0	VREG_ EN	1	1	0	1
	recommend (1Dh)		0	0	0	1	1	1	0	1

10. Sequence

10.1 Power-ON Sequence

PH :Packet Header

PD :Packet Data

PF:Packet Footer (=Checksum)

No.		Function	DNC	Command /Parameter	Type	Command/Parameter
		RESX=0				
		Wait		wait 1 msec or more		
		Power on		VDD, VCCIO on		
		Wait		wait 10 usec or more		
		RESX=1				
		MIPI signal state		keep CLK_N, CLK_P, D0_N, D0_P, D1_N, D1_P in STOP state(LP-11)		
		Wait		wait 10 msec or more		
1	EXTC Command Set enable register Page1	EXTC Command Set enable register	0	FFh	PH	[39 06 00 30]
		1st Parameter	1	FFh	PD	[FF FF 98 06 04 01]
		2nd Parameter	1	98h	PF	[XX XX]
		3rd Parameter	1	06h		
		4th Parameter	1	04h		
		5th Parameter	1	01h		
2	Interface Setting	Interface Mode Control 1	0	08h	PH	[15 08 18 0B]
		1st Parameter	1	18h		
		Display Function Control 2	0	21h	PH	[15 21 01 1B]
		1st Parameter	1	01h		
3	Panel Setting	Resolution Control	0	30h	PH	[15 30 03 15]
		1st Parameter	1	03h		
		Display Inversion Control	0	31h	PH	[15 31 00 0C]
		1st Parameter	1	00h		
		Source Timing Adjustment 1	0	60h	PH	[15 60 0D 27]
		1st Parameter	1	0Dh		
		Source Timing Adjustment 2	0	61h	PH	[15 61 08 38]
		1st Parameter	1	08h		
		Source Timing Adjustment 3	0	62h	PH	[15 62 08 3E]
		1st Parameter	1	08h		
		Source Timing Adjustment 4	0	63h	PH	[15 63 09 15]
		1st Parameter	1	09h		
4	Power control	Power Control 1	0	40h	PH	[15 40 30 03]
		1st Parameter	1	30h		
		Power Control 2	0	41h	PH	[15 41 44 2A]
		1st Parameter	1	44h		
		Power Control 3	0	42h	PH	[15 42 00 2F]
		1st Parameter	1	00h		
		Power Control 4	0	43h	PH	[15 43 89 07]
		1st Parameter	1	89h		
		Power Control 5	0	44h	PH	[15 44 8E 15]
		1st Parameter	1	8Eh		
		Power Control 6	0	45h	PH	[15 45 D9 00]
		1st Parameter	1	D9h		
		Power Control 7	0	46h	PH	[15 46 33 3F]
		1st Parameter	1	33h		
		Power Control 8	0	47h	PH	[15 47 33 25]
		1st Parameter	1	33h		
		Power Control 9	0	50h	PH	[15 50 90 21]
		1st Parameter	1	90h		
		Power Control 10	0	51h	PH	[15 51 90 3B]
		1st Parameter	1	90h		
		VCOM Control 5	0	56h	PH	[15 56 00 2A]
		1st Parameter	1	00h		

PH :Packet Header
 PD :Packet Data
 PF:Packet Footer (=Checksum)

No.	Function	DNC	Command /Parameter	Type	Command/Parameter	
5	Gamma setting	Positive Gamma Correction 1	0	A0h	PH	[15 A0 00 1C]
		1st Parameter	1	00h		
	Positive Gamma Correction 2	0	A1h	PH	[15 A1 0C 0A]	
		1st Parameter	1	0Ch		
	Positive Gamma Correction 3	0	A2h	PH	[15 A2 13 0C]	
		1st Parameter	1	13h		
	Positive Gamma Correction 4	0	A3h	PH	[15 A3 0F 15]	
		1st Parameter	1	0Fh		
	Positive Gamma Correction 5	0	A4h	PH	[15 A4 0A 35]	
		1st Parameter	1	12h		
	Positive Gamma Correction 6	0	A5h	PH	[15 A5 0D 18]	
		1st Parameter	1	0Dh		
	Positive Gamma Correction 7	0	A6h	PH	[15 A6 0C 2F]	
		1st Parameter	1	0Ch		
	Positive Gamma Correction 8	0	A7h	PH	[15 A7 0B 02]	
		1st Parameter	1	0Bh		
	Positive Gamma Correction 9	0	A8h	PH	[15 A8 01 08]	
		1st Parameter	1	01h		
	Positive Gamma Correction 10	0	A9h	PH	[15 A9 06 25]	
		1st Parameter	1	06h		
	Positive Gamma Correction 11	0	AAh	PH	[15 AA 15 2F]	
		1st Parameter	1	15h		
	Positive Gamma Correction 12	0	ABh	PH	[15 AB 07 08]	
		1st Parameter	1	16h		
	Positive Gamma Correction 13	0	ACh	PH	[15 AC 12 27]	
		1st Parameter	1	12h		
	Positive Gamma Correction 14	0	ADh	PH	[15 AD 28 07]	
		1st Parameter	1	28h		
	Positive Gamma Correction 15	0	A Eh	PH	[15 AE 20 39]	
		1st Parameter	1	20h		
	Positive Gamma Correction 16	0	AFh	PH	[15 AF 14 27]	
		1st Parameter	1	14h		
	Negative Gamma Correction	0	C0h	PH	[15 C0 00 1F]	
		1st Parameter	1	00h		
	Negative Gamma Correction 2	0	C1h	PH	[15 C1 0C 09]	
		1st Parameter	1	0Ch		
	Negative Gamma Correction 3	0	C2h	PH	[15 C2 13 0F]	
		1st Parameter	1	13h		
	Negative Gamma Correction 4	0	C3h	PH	[15 C3 0F 16]	
		1st Parameter	1	0Fh		
	Negative Gamma Correction 5	0	C4h	PH	[15 C4 09 35]	
		1st Parameter	1	11h		
	Negative Gamma Correction 6	0	C5h	PH	[15 C5 0D 1B]	
		1st Parameter	1	0Dh		
	Negative Gamma Correction 7	0	C6h	PH	[15 C6 0C 2C]	
		1st Parameter	1	0Ch		
	Negative Gamma Correction 8	0	C7h	PH	[15 C7 0B 01]	
		1st Parameter	1	0Bh		
Negative Gamma Correction 9	0	C8h	PH	[15 C8 01 0B]		
	1st Parameter	1	01h			
Negative Gamma Correction 10	0	C9h	PH	[15 C9 06 26]		
	1st Parameter	1	06h			
Negative Gamma Correction 11	0	CAh	PH	[15 CA 14 1D]		
	1st Parameter	1	14h			
Negative Gamma Correction 12	0	CBh	PH	[15 CB 07 0B]		
	1st Parameter	1	16h			
Negative Gamma Correction 13	0	CCh	PH	[15 CC 0F 16]		
	1st Parameter	1	0Fh			
Negative Gamma Correction 14	0	CDh	PH	[15 CD 21 0D]		
	1st Parameter	1	21h			
Negative Gamma Correction 15	0	C Eh	PH	[15 CE 17 3D]		
	1st Parameter	1	17h			
Negative Gamma Correction 16	0	CFh	PH	[15 CF 0A 15]		
	1st Parameter	1	0Ah			

PH :Packet Header
 PD :Packet Data
 PF:Packet Footer (=Checksum)

No.		Function	DNC	Command /Parameter	Type	Command/Parameter
6	EXTC Command Set enable register Page7	EXTXC Command Set enable register	0	FFh	PH	[39 06 00 30]
		1st Parameter	1	FFh	PD	[FF FF 98 06 04 07]
		2nd Parameter	1	98h	PF	[XX XX]
		3rd Parameter	1	06h		
		4th Parameter	1	04h		
		5th Parameter	1	07h		
7	Power control	VCL Control	0	06h	PH	[15 06 00 26]
		1st Parameter	1	11h		
		VREG1/2OUT ENABLE	0	18h	PH	[15 18 1D 28]
		1st Parameter	1	1Dh		
		VGL_REG EN	0	17h	PH	[15 17 32 18]
		1st Parameter	1	32h		
8	EXTXC Command Set enable register Page6	EXTXC Command Set enable register	0	FFh	PH	[39 06 00 30]
		1st Parameter	1	FFh	PD	[FF FF 98 06 04 06]
		2nd Parameter	1	98h	PF	[XX XX]
		3rd Parameter	1	06h		
		4th Parameter	1	04h		
		5th Parameter	1	06h		
9	GIP setting	GIP Control 1	0	00h	PH	[15 00 20 26]
		1st Parameter	1	20h		
		GIP Control 1	0	01h	PH	[15 01 02 31]
		1st Parameter	1	02h		
		GIP Control 1	0	02h	PH	[15 02 00 05]
		1st Parameter	1	00h		
		GIP Control 1	0	03h	PH	[15 03 02 2D]
		1st Parameter	1	02h		
		GIP Control 1	0	04h	PH	[15 04 01 0B]
		1st Parameter	1	01h		
		GIP Control 1	0	05h	PH	[15 05 01 11]
		1st Parameter	1	01h		
		GIP Control 1	0	06h	PH	[15 06 88 25]
		1st Parameter	1	88h		
		GIP Control 1	0	07h	PH	[15 07 00 3C]
		1st Parameter	1	00h		
		GIP Control 1	0	08h	PH	[15 08 01 0D]
		1st Parameter	1	01h		
		GIP Control 1	0	09h	PH	[15 09 80 1D]
		1st Parameter	1	80h		
		GIP Control 1	0	0Ah	PH	[15 0A 00 20]
		1st Parameter	1	00h		
		GIP Control 1	0	0Bh	PH	[15 0B 00 3A]
		1st Parameter	1	00h		
		GIP Control 1	0	0Ch	PH	[15 0C 01 2E]
		1st Parameter	1	01h		
		GIP Control 1	0	0Dh	PH	[15 0D 01 34]
		1st Parameter	1	01h		
		GIP Control 1	0	0Eh	PH	[15 0E 00 03]
		1st Parameter	1	00h		
		GIP Control 1	0	0Fh	PH	[15 0F 00 19]
		1st Parameter	1	00h		
		GIP Control 1	0	10h	PH	[15 10 55 02]
		1st Parameter	1	55h		
		GIP Control 1	0	11h	PH	[15 11 50 1D]
		1st Parameter	1	50h		
		GIP Control 1	0	12h	PH	[15 12 01 12]
		1st Parameter	1	01h		
		GIP Control 1	0	13h	PH	[15 13 00 39]
		1st Parameter	1	00h		
GIP Control 1	0	14h	PH	[15 14 00 1C]		
1st Parameter	1	00h				
GIP Control 1	0	15h	PH	[15 15 43 32]		
1st Parameter	1	43h				
GIP Control 1	0	16h	PH	[15 16 0B 3B]		
1st Parameter	1	0Bh				

PH :Packet Header
 PD :Packet Data
 PF:Packet Footer (=Checksum)

No.	Function	DNC	Command /Parameter	Type	Command/Parameter
	GIP Control 1	0	17h	PH	[15 17 00 1A]
	1st Parameter	1	00h		
	GIP Control 1	0	18h	PH	[15 18 00 1A]
	1st Parameter	1	00h		
	GIP Control 1	0	19h	PH	[15 19 00 00]
	1st Parameter	1	00h		
	GIP Control 1	0	1Ah	PH	[15 1A 00 06]
	1st Parameter	1	00h		
	GIP Control 1	0	1Bh	PH	[15 1B 00 1C]
	1st Parameter	1	00h		
	GIP Control 1	0	1Ch	PH	[15 1C 00 39]
	1st Parameter	1	00h		
	GIP Control 1	0	1Dh	PH	[15 1D 00 23]
	1st Parameter	1	00h		
	GIP Control 2	0	20h	PH	[15 20 01 01]
	1st Parameter	1	01h		
	GIP Control 2	0	21h	PH	[15 21 23 16]
	1st Parameter	1	23h		
	GIP Control 2	0	22h	PH	[15 22 45 1E]
	1st Parameter	1	45h		
	GIP Control 2	0	23h	PH	[15 23 67 09]
	1st Parameter	1	67h		
	GIP Control 2	0	24h	PH	[15 24 01 22]
	1st Parameter	1	01h		
	GIP Control 2	0	25h	PH	[15 25 23 35]
	1st Parameter	1	23h		
	GIP Control 2	0	26h	PH	[15 26 45 3D]
	1st Parameter	1	45h		
	GIP Control 2	0	27h	PH	[15 27 67 2A]
	1st Parameter	1	67h		
	GIP Control 3	0	30h	PH	[15 30 02 24]
	1st Parameter	1	02h		
	GIP Control 3	0	31h	PH	[15 31 22 01]
	1st Parameter	1	22h		
	GIP Control 3	0	32h	PH	[15 32 22 07]
	1st Parameter	1	22h		
	GIP Control 3	0	33h	PH	[15 33 88 13]
	1st Parameter	1	88h		
	GIP Control 3	0	34h	PH	[15 34 AA 3B]
	1st Parameter	1	AAh		
	GIP Control 3	0	35h	PH	[15 35 BB 1F]
	1st Parameter	1	BBh		
	GIP Control 3	0	36h	PH	[15 36 66 27]
	1st Parameter	1	66h		
	GIP Control 3	0	37h	PH	[15 37 22 3E]
	1st Parameter	1	22h		
	GIP Control 3	0	38h	PH	[15 38 22 3E]
	1st Parameter	1	22h		
	GIP Control 3	0	39h	PH	[15 39 22 24]
	1st Parameter	1	22h		
	GIP Control 3	0	3Ah	PH	[15 3A 22 22]
	1st Parameter	1	22h		
	GIP Control 3	0	3Bh	PH	[15 3B 22 38]
	1st Parameter	1	22h		
	GIP Control 3	0	3Ch	PH	[15 3C 22 1D]
	1st Parameter	1	22h		
	GIP Control 3	0	3Dh	PH	[15 3D 22 07]
	1st Parameter	1	22h		
	GIP Control 3	0	3Eh	PH	[15 3E 22 01]
	1st Parameter	1	22h		
	GIP Control 3	0	3Fh	PH	[15 3F 22 1B]
	1st Parameter	1	22h		
	GIP Control 3	0	40h	PH	[15 40 22 3E]
	1st Parameter	1	22h		
	GOUT VGLO Control	0	53h	PH	[15 53 12 2E]
	1st Parameter	1	12h		

PH :Packet Header
 PD :Packet Data
 PF:Packet Footer (=Checksum)

No.	Function	DNC	Command /Parameter	Type	Command/Parameter	
10	EXTC Command Set enable register Page0	EXTXC Command Set enable register	0	FFh	PH	[39 06 00 30]
		1st Parameter	1	FFh	PD	[FF FF 98 06 04 00]
		2nd Parameter	1	98h	PF	[XX XX]
		3rd Parameter	1	06h		
		4th Parameter	1	04h		
		5th Parameter	1	00h		
11	Interface Pixel Format	Interface Pixel Format	0	3Ah	PH	[15 3A 60 27]
		1st Parameter	1	60h		
12	Sleep Out Wait	recommend	0	11h	PH	[05 11 00 36]
		wait 120 msec or more				
13	Display on	Digital Gamma Control 1	0	29h	PH	[05 29 00 1C]

10.2 Power-OFF Sequence

No.	Function	DNC	Command /Parameter	Type	Command/Parameter	
1	Display off	Display off	0	28h	PH	[05 28 00 06]
	Wait	wait 5 msec or more				
2	Sleep in	Sleep in	0	10h	PH	[05 10 00 2C]
	Wait	wait 2 frames or more				
3	Video signals	Video signals stop				

↓
Power off

10.3 Sleep Sequence

No.	Function	DNC	Command /Parameter	Type	Command/Parameter	
1	Display off	Display off	0	28h	PH	[05 28 00 06]
	Wait	wait 5 msec or more				
2	Sleep in	Sleep in	0	10h	PH	[05 10 00 2C]
	Wait	wait 2 frames or more				
3	Video signals	Video signals stop				

10.4 Sleep Release Sequence

No.	Function	DNC	Command /Parameter	Type	Command/Parameter	
1	Video signals	Video signals start				
	Wait	wait 2 frames or more				
2	Sleep out	Sleep out	0	11h	PH	[05 11 00 36]
	Wait	wait 120 msec or more				
3	Display on	Display on	0	29h	PH	[05 29 00 1C]

10.5 ID Read Sequence

No.	Function	DNC	Command /Parameter	Type	Command/Parameter	
1	EXTXC Command Set enable register Page1	EXTXC Command Set enable register	0	FFh	PH	[39 06 00 30]
		1st Parameter	1	FFh	PD	[FF FF 98 06 04 01]
		2nd Parameter	1	98h	PF	[XX XX]
		3rd Parameter	1	06h		
		4th Parameter	1	04h		
		5th Parameter	1	01h		
2	Set Maximum Return Packet Size	-	-	PH	[37 01 00 1D]	
3	DCS Read, No Parameter	0	00h	PH	[06 00 00 06]	
4	Set Maximum Return Packet Size	-	-	PH	[37 01 00 1D]	
5	DCS Read, No Parameter	0	01h	PH	[06 01 01 2D]	
6	Set Maximum Return Packet Size	-	-	PH	[37 01 00 1D]	
7	DCS Read, No Parameter	0	02h	PH	[06 02 02 28]	
8	EXTXC Command Set enable register Page0	EXTXC Command Set enable register	0	FFh	PH	[39 06 00 30]
		1st Parameter	1	FFh	PD	[FF FF 98 06 04 00]
		2nd Parameter	1	98h	PF	[XX XX]
		3rd Parameter	1	06h		
		4th Parameter	1	04h		
		5th Parameter	1	00h		

10.6 Power ON/OFF timing

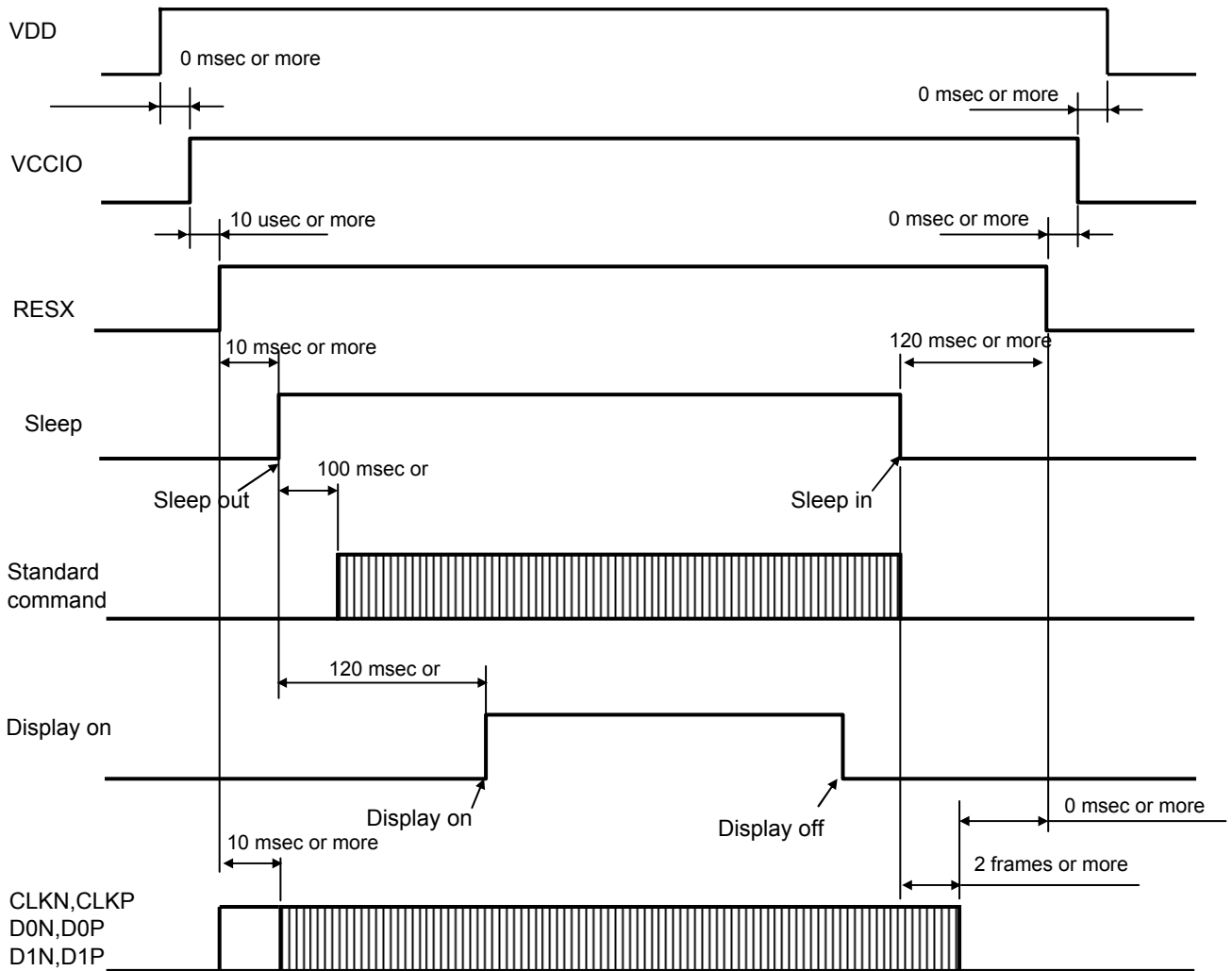

10.7 Refresh Sequence

PH :Packet Header

PD :Packet Data

PF:Packet Footer (=Checksum)

No.	Function	DNC	Command /Parameter	Type	Command/Parameter	
1	EXTC Command Set enable register Page1	EXTC Command Set enable register	0	FFh	PH	[39 06 00 30]
		1st Parameter	1	FFh	PD	[FF FF 98 06 04 01]
		2nd Parameter	1	98h	PF	[XX XX]
		3rd Parameter	1	06h		
		4th Parameter	1	04h		
		5th Parameter	1	01h		
2	Interface Setting	Interface Mode Control 1	0	08h	PH	[15 08 18 0B]
		1st Parameter	1	18h		
		Display Function Control 2	0	21h	PH	[15 21 01 1B]
		1st Parameter	1	01h		
3	Panel Setting	Resolution Control	0	30h	PH	[15 30 03 15]
		1st Parameter	1	03h		
		Display Inversion Control	0	31h	PH	[15 31 00 0C]
		1st Parameter	1	00h		
		Source Timing Adjustment 1	0	60h	PH	[15 60 0D 27]
		1st Parameter	1	0Dh		
		Source Timing Adjustment 2	0	61h	PH	[15 61 08 38]
		1st Parameter	1	08h		
		Source Timing Adjustment 3	0	62h	PH	[15 62 08 3E]
		1st Parameter	1	08h		
		Source Timing Adjustment 4	0	63h	PH	[15 63 09 15]
		1st Parameter	1	09h		
4	Power control	Power Control 1	0	40h	PH	[15 40 30 03]
		1st Parameter	1	30h		
		Power Control 2	0	41h	PH	[15 41 44 2A]
		1st Parameter	1	44h		
		Power Control 3	0	42h	PH	[15 42 00 2F]
		1st Parameter	1	00h		
		Power Control 4	0	43h	PH	[15 43 89 07]
		1st Parameter	1	89h		
		Power Control 5	0	44h	PH	[15 44 8E 15]
		1st Parameter	1	8Eh		
		Power Control 6	0	45h	PH	[15 45 D9 00]
		1st Parameter	1	D9h		
		Power Control 7	0	46h	PH	[15 46 33 3F]
		1st Parameter	1	33h		
		Power Control 8	0	47h	PH	[15 47 33 25]
		1st Parameter	1	33h		
		Power Control 9	0	50h	PH	[15 50 90 21]
		1st Parameter	1	90h		
		Power Control 10	0	51h	PH	[15 51 90 3B]
		1st Parameter	1	90h		
	VCOM Control 5	0	56h	PH	[15 56 00 2A]	
	1st Parameter	1	00h			

PH :Packet Header
 PD :Packet Data
 PF:Packet Footer (=Checksum)

No.	Function	DNC	Command /Parameter	Type	Command/Parameter
5	Gamma setting				
	Positive Gamma Correction 1	0	A0h	PH	[15 A0 00 1C]
	1st Parameter	1	00h		
	Positive Gamma Correction 2	0	A1h	PH	[15 A1 0C 0A]
	1st Parameter	1	0Ch		
	Positive Gamma Correction 3	0	A2h	PH	[15 A2 13 0C]
	1st Parameter	1	13h		
	Positive Gamma Correction 4	0	A3h	PH	[15 A3 0F 15]
	1st Parameter	1	0Fh		
	Positive Gamma Correction 5	0	A4h	PH	[15 A4 0A 35]
	1st Parameter	1	12h		
	Positive Gamma Correction 6	0	A5h	PH	[15 A5 0D 18]
	1st Parameter	1	0Dh		
	Positive Gamma Correction 7	0	A6h	PH	[15 A6 0C 2F]
	1st Parameter	1	0Ch		
	Positive Gamma Correction 8	0	A7h	PH	[15 A7 0B 02]
	1st Parameter	1	0Bh		
	Positive Gamma Correction 9	0	A8h	PH	[15 A8 01 08]
	1st Parameter	1	01h		
	Positive Gamma Correction 10	0	A9h	PH	[15 A9 06 25]
	1st Parameter	1	06h		
	Positive Gamma Correction 11	0	AAh	PH	[15 AA 15 2F]
	1st Parameter	1	15h		
	Positive Gamma Correction 12	0	ABh	PH	[15 AB 07 08]
	1st Parameter	1	16h		
	Positive Gamma Correction 13	0	ACh	PH	[15 AC 12 27]
	1st Parameter	1	12h		
	Positive Gamma Correction 14	0	ADh	PH	[15 AD 28 07]
	1st Parameter	1	28h		
	Positive Gamma Correction 15	0	A Eh	PH	[15 AE 20 39]
	1st Parameter	1	20h		
	Positive Gamma Correction 16	0	A Fh	PH	[15 AF 14 27]
	1st Parameter	1	14h		
	Negative Gamma Correction	0	C0h	PH	[15 C0 00 1F]
	1st Parameter	1	00h		
	Negative Gamma Correction 2	0	C1h	PH	[15 C1 0C 09]
	1st Parameter	1	0Ch		
	Negative Gamma Correction 3	0	C2h	PH	[15 C2 13 0F]
	1st Parameter	1	13h		
	Negative Gamma Correction 4	0	C3h	PH	[15 C3 0F 16]
	1st Parameter	1	0Fh		
	Negative Gamma Correction 5	0	C4h	PH	[15 C4 09 35]
	1st Parameter	1	11h		
	Negative Gamma Correction 6	0	C5h	PH	[15 C5 0D 1B]
	1st Parameter	1	0Dh		
	Negative Gamma Correction 7	0	C6h	PH	[15 C6 0C 2C]
	1st Parameter	1	0Ch		
	Negative Gamma Correction 8	0	C7h	PH	[15 C7 0B 01]
1st Parameter	1	0Bh			
Negative Gamma Correction 9	0	C8h	PH	[15 C8 01 0B]	
1st Parameter	1	01h			
Negative Gamma Correction 10	0	C9h	PH	[15 C9 06 26]	
1st Parameter	1	06h			
Negative Gamma Correction 11	0	CAh	PH	[15 CA 14 1D]	
1st Parameter	1	14h			
Negative Gamma Correction 12	0	CBh	PH	[15 CB 07 0B]	
1st Parameter	1	16h			
Negative Gamma Correction 13	0	CCh	PH	[15 CC 0F 16]	
1st Parameter	1	0Fh			
Negative Gamma Correction 14	0	CDh	PH	[15 CD 21 0D]	
1st Parameter	1	21h			
Negative Gamma Correction 15	0	C Eh	PH	[15 CE 17 3D]	
1st Parameter	1	17h			
Negative Gamma Correction 16	0	C Fh	PH	[15 CF 0A 15]	
1st Parameter	1	0Ah			

PH :Packet Header
 PD :Packet Data
 PF:Packet Footer (=Checksum)

No.		Function	DNC	Command /Parameter	Type	Command/Parameter
6	EXTC Command Set enable register Page7	EXTC Command Set enable register	0	FFh	PH	[39 06 00 30]
		1st Parameter	1	FFh	PD	[FF FF 98 06 04 07]
		2nd Parameter	1	98h	PF	[XX XX]
		3rd Parameter	1	06h		
		4th Parameter	1	04h		
		5th Parameter	1	07h		
7	Power control	VCL Control	0	06h	PH	[15 06 00 26]
		1st Parameter	1	11h		
		VREG1/2OUT ENABLE	0	18h	PH	[15 18 1D 28]
		1st Parameter	1	1Dh		
		VGL_REG EN	0	17h	PH	[15 17 32 18]
		1st Parameter	1	32h		
8	EXTC Command Set enable register Page6	EXTC Command Set enable register	0	FFh	PH	[39 06 00 30]
		1st Parameter	1	FFh	PD	[FF FF 98 06 04 06]
		2nd Parameter	1	98h	PF	[XX XX]
		3rd Parameter	1	06h		
		4th Parameter	1	04h		
		5th Parameter	1	06h		
9	GIP setting	GIP Control 1	0	00h	PH	[15 00 20 26]
		1st Parameter	1	20h		
		GIP Control 1	0	01h	PH	[15 01 02 31]
		1st Parameter	1	02h		
		GIP Control 1	0	02h	PH	[15 02 00 05]
		1st Parameter	1	00h		
		GIP Control 1	0	03h	PH	[15 03 02 2D]
		1st Parameter	1	02h		
		GIP Control 1	0	04h	PH	[15 04 01 0B]
		1st Parameter	1	01h		
		GIP Control 1	0	05h	PH	[15 05 01 11]
		1st Parameter	1	01h		
		GIP Control 1	0	06h	PH	[15 06 88 25]
		1st Parameter	1	88h		
		GIP Control 1	0	07h	PH	[15 07 00 3C]
		1st Parameter	1	00h		
		GIP Control 1	0	08h	PH	[15 08 01 0D]
		1st Parameter	1	01h		
		GIP Control 1	0	09h	PH	[15 09 80 1D]
		1st Parameter	1	80h		
		GIP Control 1	0	0Ah	PH	[15 0A 00 20]
		1st Parameter	1	00h		
		GIP Control 1	0	0Bh	PH	[15 0B 00 3A]
		1st Parameter	1	00h		
		GIP Control 1	0	0Ch	PH	[15 0C 01 2E]
		1st Parameter	1	01h		
		GIP Control 1	0	0Dh	PH	[15 0D 01 34]
		1st Parameter	1	01h		
		GIP Control 1	0	0Eh	PH	[15 0E 00 03]
		1st Parameter	1	00h		
		GIP Control 1	0	0Fh	PH	[15 0F 00 19]
		1st Parameter	1	00h		
		GIP Control 1	0	10h	PH	[15 10 55 02]
		1st Parameter	1	55h		
		GIP Control 1	0	11h	PH	[15 11 50 1D]
		1st Parameter	1	50h		
		GIP Control 1	0	12h	PH	[15 12 01 12]
		1st Parameter	1	01h		
		GIP Control 1	0	13h	PH	[15 13 00 39]
		1st Parameter	1	00h		
GIP Control 1	0	14h	PH	[15 14 00 1C]		
1st Parameter	1	00h				
GIP Control 1	0	15h	PH	[15 15 43 32]		
1st Parameter	1	43h				
GIP Control 1	0	16h	PH	[15 16 0B 3B]		
1st Parameter	1	0Bh				

PH :Packet Header
 PD :Packet Data
 PF:Packet Footer (=Checksum)

No.	Function	DNC	Command /Parameter	Type	Command/Parameter
	GIP Control 1	0	17h	PH	[15 17 00 1A]
	1st Parameter	1	00h		
	GIP Control 1	0	18h	PH	[15 18 00 1A]
	1st Parameter	1	00h		
	GIP Control 1	0	19h	PH	[15 19 00 00]
	1st Parameter	1	00h		
	GIP Control 1	0	1Ah	PH	[15 1A 00 06]
	1st Parameter	1	00h		
	GIP Control 1	0	1Bh	PH	[15 1B 00 1C]
	1st Parameter	1	00h		
	GIP Control 1	0	1Ch	PH	[15 1C 00 39]
	1st Parameter	1	00h		
	GIP Control 1	0	1Dh	PH	[15 1D 00 23]
	1st Parameter	1	00h		
	GIP Control 2	0	20h	PH	[15 20 01 01]
	1st Parameter	1	01h		
	GIP Control 2	0	21h	PH	[15 21 23 16]
	1st Parameter	1	23h		
	GIP Control 2	0	22h	PH	[15 22 45 1E]
	1st Parameter	1	45h		
	GIP Control 2	0	23h	PH	[15 23 67 09]
	1st Parameter	1	67h		
	GIP Control 2	0	24h	PH	[15 24 01 22]
	1st Parameter	1	01h		
	GIP Control 2	0	25h	PH	[15 25 23 35]
	1st Parameter	1	23h		
	GIP Control 2	0	26h	PH	[15 26 45 3D]
	1st Parameter	1	45h		
	GIP Control 2	0	27h	PH	[15 27 67 2A]
	1st Parameter	1	67h		
	GIP Control 3	0	30h	PH	[15 30 02 24]
	1st Parameter	1	02h		
	GIP Control 3	0	31h	PH	[15 31 22 01]
	1st Parameter	1	22h		
	GIP Control 3	0	32h	PH	[15 32 22 07]
	1st Parameter	1	22h		
	GIP Control 3	0	33h	PH	[15 33 88 13]
	1st Parameter	1	88h		
	GIP Control 3	0	34h	PH	[15 34 AA 3B]
	1st Parameter	1	AAh		
	GIP Control 3	0	35h	PH	[15 35 BB 1F]
	1st Parameter	1	BBh		
	GIP Control 3	0	36h	PH	[15 36 66 27]
	1st Parameter	1	66h		
	GIP Control 3	0	37h	PH	[15 37 22 3E]
	1st Parameter	1	22h		
	GIP Control 3	0	38h	PH	[15 38 22 3E]
	1st Parameter	1	22h		
	GIP Control 3	0	39h	PH	[15 39 22 24]
	1st Parameter	1	22h		
	GIP Control 3	0	3Ah	PH	[15 3A 22 22]
	1st Parameter	1	22h		
	GIP Control 3	0	3Bh	PH	[15 3B 22 38]
	1st Parameter	1	22h		
	GIP Control 3	0	3Ch	PH	[15 3C 22 1D]
	1st Parameter	1	22h		
	GIP Control 3	0	3Dh	PH	[15 3D 22 07]
	1st Parameter	1	22h		
	GIP Control 3	0	3Eh	PH	[15 3E 22 01]
	1st Parameter	1	22h		
	GIP Control 3	0	3Fh	PH	[15 3F 22 1B]
	1st Parameter	1	22h		
	GIP Control 3	0	40h	PH	[15 40 22 3E]
	1st Parameter	1	22h		
	GOUT VGLO Control	0	53h	PH	[15 53 12 2E]
	1st Parameter	1	12h		

PH :Packet Header
 PD :Packet Data
 PF:Packet Footer (=Checksum)

No.		Function	DNC	Command /Parameter	Type	Command/Parameter
10	EXTC Command Set enable register Page0	EXTC Command Set enable register	0	FFh	PH	[39 06 00 30]
		1st Parameter	1	FFh	PD	[FF FF 98 06 04 00]
		2nd Parameter	1	98h	PF	[XX XX]
		3rd Parameter	1	06h		
		4th Parameter	1	04h		
		5th Parameter	1	00h		
11	Interface Pixel Format	Interface Pixel Format	0	3Ah	PH	[15 3A 60 27]
		1st Parameter	1	60h		
12	Sleep Out Wait	recommend	0	11h	PH	[05 11 00 36]
		wait 120 msec or more				
13	Display on	Digital Gamma Control 1	0	29h	PH	[05 29 00 1C]

11. Characteristics

11.1 Optical Characteristics

< Measurement Condition >

Measuring instruments: CS1000 (KONICA MINOLTA), LCD7200(OTSUKA ELECTRONICS),
EZcontrast160D (ELDIM)

Driving condition: VDD = 2.8V, VCCIO = 1.8V
Optimized VCOMDC

Backlight: IL=20.0mA

Measured temperature: Ta=25° C

Item		Symbol	Condition	MIN	TYP	MAX	Unit	Note No.	Remark
Response time	Rise time	TON	[Data]= 00h→FFh	—	—	40	ms	1	※
	Fall time	TOFF	[Data]= FFh→00h	—	—	60	ms		
Contrast ratio	Backlight ON	CR	[Data]= FFh / 00h	630	900	—		2	
	Backlight OFF				2				
Viewing angle	Left	θL	[Data]= FFh / 00h CR ≥ 10	80	—	—	deg	3	
	Right	θR		80	—	—	deg		
	Up	φU		80	—	—	deg		
	Down	φD		80	—	—	deg		
White Chromaticity	x	[Data]= FFh	White chromaticity range					4	
	y								
Burn-in				No noticeable burn-in image should be observed after 2 hours of window pattern display.				5	
Center brightness			[Data]= FFh	650	900	—	cd/m ²	6	
Brightness distribution			[Data]= FFh	70	—	—	%	7	

* Note number 1 to 7: Refer to the APPENDIX of "Reference Method for Measuring Optical Characteristics".

※ Measured in the form of LCD module.

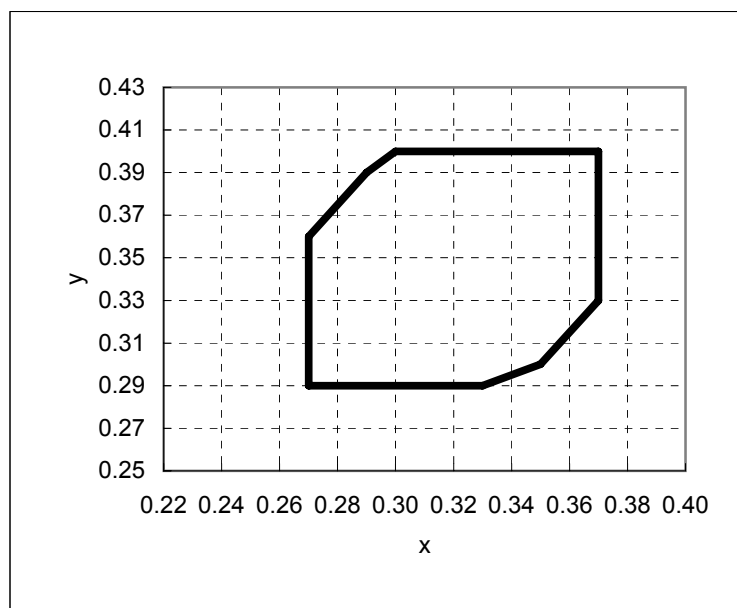

White Chromaticity Range

【White Chromaticity Range】

x	y
0.30	0.40
0.29	0.39
0.27	0.36
0.27	0.29
0.33	0.29
0.35	0.30
0.37	0.33
0.37	0.40

11.2 Temperature Characteristics

< Measurement Condition >

Measuring instruments: CS1000 (KONICA MINOLTA), LCD7200(OTSUKA ELECTRONICS)

Driving condition: VDD = 2.8V, VCCIO = 1.8V

Optimized VCOMDC

Backlight: IL=20.0mA

Item		Specification		Remark	
		Ta = -10 °C	Ta = 70 °C		
Contrast ratio	CR	40 or more	40 or more	Backlight ON	
Response time	Rise time	TON	200 msec or less	30 msec or less	※
	Fall time	TOFF	300 msec or less	50 msec or less	※
Display Quality		No noticeable display defect or nonuniformity should be observed.		Use the criteria for judgment specified in the section 12.	

※ Measured in the form of LCD module.

12. Criteria of Judgment

12.1 Defective Display and Screen Quality

Test Condition:	Observed TFT-LCD monitor from front during operation with the following conditions
Driving Signal	Raster Patter (RGB, white, black)
Signal condition	[Data]: 00h, 94h, FFh (3steps)
Observation distance	30 cm
Illuminance	200 to 350 lx
Backlight	IL=20.0mA

Defect item	Defect content	Criteria		
Display Quality	Line defect	Black, white or color line, 3 or more neighboring defective dots	Not exists	
	Dot defect	Uneven brightness on dot-by-dot base due to defective TFT or CF, or dust is counted as dot defect (brighter dot, darker dot)	Refer to table 1	
		High bright dot: Visible through 2% ND filter at [Data]=00h		
		Low bright dot: Visible through 5% ND filter at [Data]=00h Dark dot: Appear dark through white display at [Data]=94h Invisible through 5% ND filter at [Data]=00h		ignored
Screen Quality	Dirt	Uneven brightness (white stain, black stain etc)	Invisible through 1% ND filter	
	Foreign particle	Point-like	$0.25\text{mm} < \varphi$	$N=0$
			$0.20\text{mm} < \varphi \leq 0.25\text{mm}$	$N \leq 2$
			$\varphi \leq 0.20\text{mm}$	Ignored
		Liner	$3.0\text{mm} < \text{length and } 0.08\text{mm} < \text{width}$	$N=0$
	$\text{length} \leq 3.0\text{mm}$ or $\text{width} \leq 0.08\text{mm}$		Ignored	
Others		Use boundary sample for judgment when necessary		

φ (mm): Average diameter = (major axis + minor axis)/2
Permissible number: N

Table 1

Area	High bright dot	Low bright dot	Dark dot	Total	Criteria
A	0	2	2	3	Permissible distance between same color bright dots (includes neighboring dots): 3 mm or more Permissible distance between same color high bright dots (includes neighboring dots): 5 mm or more
B	2	4	4	6	
Total	2	4	4	7	

<Portrait model>

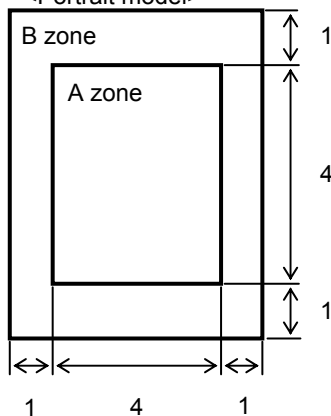

Division of A and B areas

B area: Active area

Dimensional ratio between A and B areas: 1: 4: 1 (Refer to the left figure)

12.2 Screen and Other Appearance

Testing conditions

Observation distance 30cm
 Illuminance 1200~2000 lx

Item	Criteria	Remark
Polarizer Flaw Stain Bubble Dust Dent	Ignore invisible defect when the backlight is on.	Applicable area: Active area only (Refer to the section 3.2 "Outward form")
S-case	No functional defect occurs	
FPC cable	No functional defect occurs	

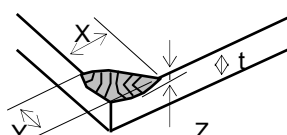
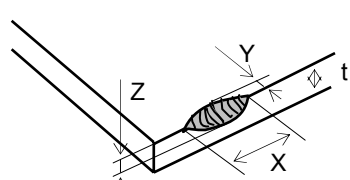
Item	Appearance	Criteria
Glass Chipping	Corner area 	Unit: mm $X \leq 3$ $Y \leq 3$ $Z \leq t$ (t:glass thickness) $X, Y \leq 0.5$ is ignored.
	Others 	Unit: mm $X \leq 5$ $Y \leq 1$ $Z \leq t$ (t:glass thickness) $X, Y \leq 0.5$ is ignored.
	Progressive crack	None

13. Reliability Test

Test item		Test condition		number of failures /number of examinations
Durability test	High temperature storage	Ta=80° C	240h	0 / 3
	Low temperature storage	Ta=-30° C	240h	0 / 3
	High temperature & high humidity storage	Ta=60° C, RH=90% non condensing	240h	0 / 3
	High temperature operation	Tp=70° C	240h	0 / 3
	Low temperature operation	Tp=-20° C	240h	0 / 3
	High temp & humid operation	Tp=40° C, RH=90% non condensing	240h	0 / 3
	Thermal shock storage	-30←→80° C(30min/30min)	100 cycles	0 / 3
Mechanical environmental test	Electrostatic discharge test (Non operation)	Confirms to EIAJ ED-4701/300 C=200pF,R=0Ω,V=±200V Each 3 times of discharge on and power supply and other terminals.		0 / 3
	Surface discharge test (Non operation)	C=250pF, R=100Ω, V=±8kV Each 5 times of discharge in both polarities on the center of screen with the case grounded.		0 / 3
	Vibration test	Total amplitude 1.5mm, f=10~55Hz, X,Y,Z directions for each 2 hours		0 / 3
	Impact test	Use ORTUS TECHNOLOGY original jig (see next page)and make an impact with peak acceleration of 1000m/s ² for 6 msec with half sine-curve at 3 times to each X, Y, Z directions in conformance with JIS C 60068-2-27-2011.		0 / 3
Packing test	Packing vibration-proof test	Acceleration of 19.6m/s ² with frequency of 10→55→10Hz, X,Y, Zdirection for each 30 minutes		0 / 1 packing
	Packing drop test	Drop from 75cm high. 1 time to each 6 surfaces, 3 edges, 1 corner		0 / 1 packing

Note: Ta=ambient temperature Tp=Panel temperature

※ The profile of high temperature/humidity storage and High Temperature/humidity operation (Pure water of over 10MΩ·cm shall be used.)

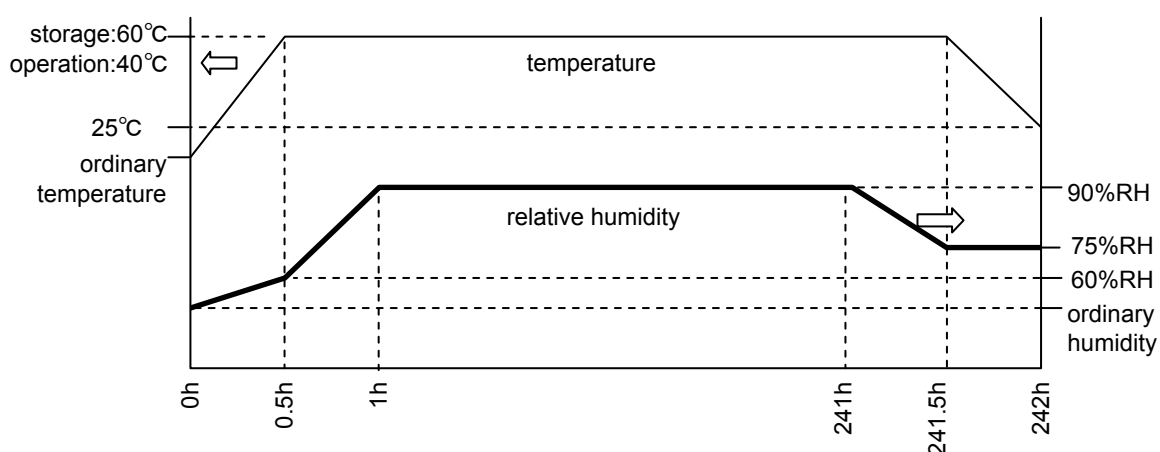
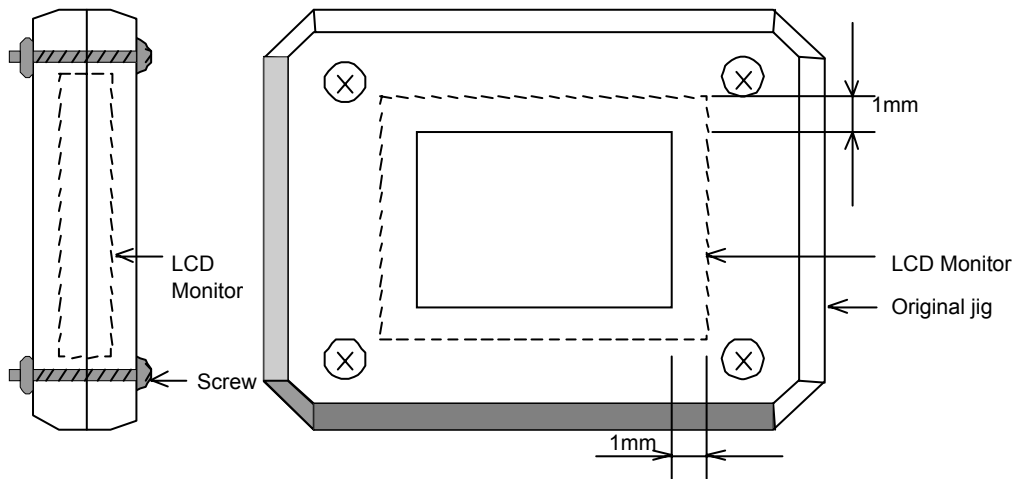

Table2.Reliability Criteria

The parameters should be measured after leaving the monitor at the ordinary temperature for 24 hours or more after the test completion.

item	Standard	Remarks
Display quality	No visible abnormality shall be seen. (Except for unevenness by PoI deterioration.)	
Contrast ratio	40 or more	Backlight ON

ORTUS TECHNOLOGY Original Jig



14. Packing Specifications

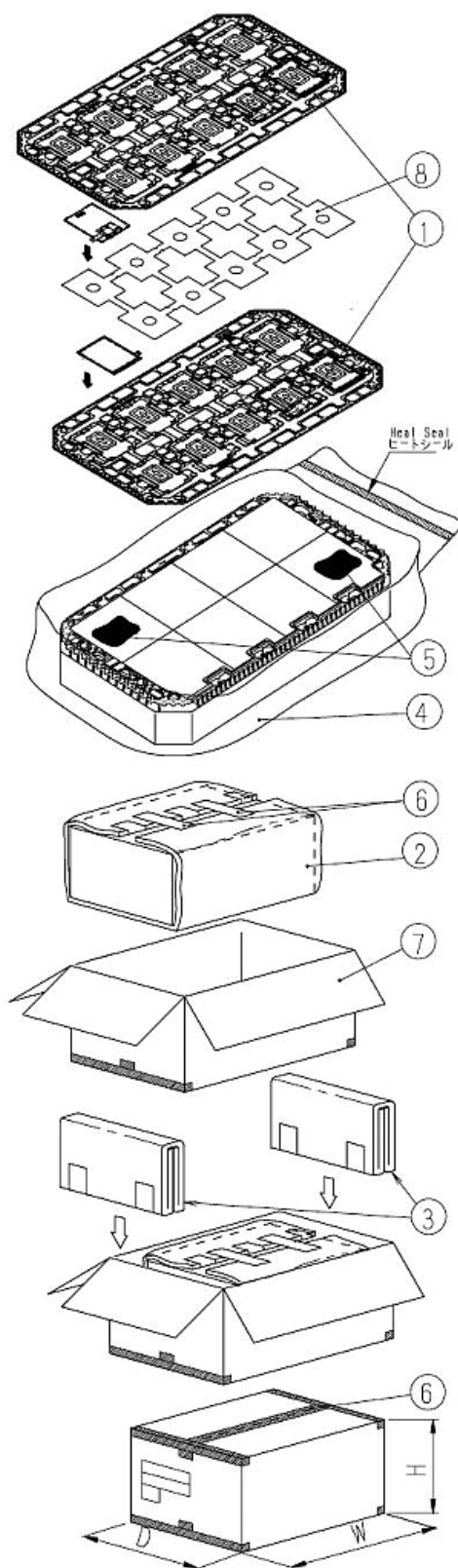

- [Step1] • Each product is to be placed on the tray with it's the display surface facing upward. (10 products per the first step.)
 • Foam sheet is to be placed on the products in the tray.
 • Each product is to be placed on the tray with it's the display surface facing downward. (10 products per the second step.)
 • Foam sheet is to be placed on the products in the tray.
- [Step2] • Trays be in a stack of 8.
 • One empty tray is to be put on the top of stack of 8 packed trays.
- [Step3] • 2 packs of moisture absorbers are to be placed on the top tray as shown in drawing.
 • Put piled trays into a sealing bag.
- [Step4] • Vacuum and seal the sealing bag with the vacuum sealing machine.
- [Step5] • Put in the sealing bag in the center of the B SHEET C.
 • The piled trays are to be wrapped with the B SHEET C, and to be fixed with adhesive tape.
- [Step6] • The wrapped trays are placed in the outer carton.
- [Step7] • B SHEET D is to be inserted into a outer carton with same orientation.
 • The outer carton is to be sealed in H-shape with packing tape as shown in the drawing.
- [Step8] • The model number, quantity of products, and shipping date are to be printed on the 2 opposite sides of the outer carton with black ink.
 • If necessary, shipping labels or impression marking are to be put on the outer carton.

Remark: The return of packing materials is not required.

	Packing item name	Specs., Material
①	Tray	A-PET
②	B SHEET C	Anti-static air babble sheet
③	B SHEET D	Anti-static air babble sheet
④	Sealing bag	
⑤	Drier	Moisture absorber
⑥	Adhesive tape.	
⑦	Outer carton	Corrugated cardboard
⑧	Foam sheet	Anti-static polyethylene

Dimension of extra outer carton	
D : Approx.	(356mm)
W : Approx.	(664mm)
H : Approx.	(182mm)
Quantity of products packed in one carton:	10 pcs × 2 stacks × 8 trays = 160 pieces
Gross weight : Approx.	7.2Kg

15. Handling Instruction

15.1 Cautions for Handling LCD panels

**Caution**

- (1) Do not make an impact on the LCD panel glass because it may break and you may get injured from it.
- (2) If the glass breaks, do not touch it with bare hands.
(Fragment of broken glass may stick you or you cut yourself on it.)
- (3) If you get injured, receive adequate first aid and consult a medial doctor.
- (4) Do not let liquid crystal get into your mouth.
(If the LCD panel glass breaks, try not let liquid crystal get into your mouth even toxic property of liquid crystal has not been confirmed.)
- (5) If liquid crystal adheres, rinse it out thoroughly.
(If liquid crystal adheres to your cloth or skin, wipe it off with rubbing alcohol or wash it thoroughly with soap. If liquid crystal gets into eyes, rinse it with clean water for at least 15 minutes and consult an eye doctor.)
- (6) If you scrap this products, follow a disposal standard of industrial waste that is legally valid in the community, country or territory where you reside.
- (7) Do not connect or disconnect this product while its application products is powered on.
- (8) Do not attempt to disassemble or modify this product as it is precision component.
- (9) If a part of soldering part has been exposed, and avoid contact (short-circuit) with a metallic part of the case etc. about FPC of this model, please.
Please insulate it with the insulating tape etc. if necessary.
The defective operation is caused, and there is a possibility to generation of heat and the ignition.
- (10) Since excess current protection circuit is not built in this TFT module, there is the possibility that LCD module or peripheral circuit become feverish and burned in case abnormal operation is generated.
We recommend you to add excess current protection circuit to power supply.
- (11) The devices on the FPC are damageable to electrostatic discharge, because the terminals of the devices are exposed.
Wear grounded wrist-straps and use electrostatic neutralization blowers to prevent static charge and discharge when handling the TFT monitors.
Designate an appropriate operating area, and set equipment, tools, and machines properly when handling this product.

**Caution**

This mark is used to indicate a precaution or an instruction which, if not correctly observed, may result in bodily injury, or material damages alone.

15.2 Precautions for Handling

- 1) Wear finger tips at incoming inspection and for handling the TFT monitors to keep display quality and keep the working area clean.
Do not touch the surface of the monitor as it is easily scratched.
- 2) Wear grounded wrist-straps and use electrostatic neutralization blowers to prevent static charge and discharge when handling the TFT monitors as the LED in this TFT monitors is damageable to electrostatic discharge.
Designate an appropriate operating area, and set equipment, tools, and machines properly when handling this product.
- 3) Avoid strong mechanical shock including knocking, hitting or dropping to the TFT monitors for protecting their glass parts. Do not use the TFT monitors that have been experienced dropping or strong mechanical shock.
- 4) Do not use or storage the TFT monitors at high temperature and high humidity environment. Particularly, never use or storage the TFT monitors at a location where condensation builds up.
- 5) Avoid using and storing TFT monitors at a location where they are exposed to direct sunlight or ultraviolet rays to prevent the LCD panels from deterioration by ultraviolet rays.
- 6) Do not stain or damage the contacts of the FPC cable .
FPC cable needs to be inserted until it can reach to the end of connector slot.
During insertion, make sure to keep the cable in a horizontal position to avoid an oblique insertion.
Otherwise, it may cause poor contact or deteriorate reliability of the FPC cable.
- 7) The FPC cable is a design very weak to the bend and the pull as it is fixed with the tape.
Do not bend or pull the FPC cable or carry the TFT monitor by holding the FPC cable.
- 8) Peel off the protective film on the TFT monitors during mounting process.
Refer to the section 15.5 on how to peel off the protective film.
We are not responsible for electrostatic discharge failures or other defects occur when peeling off the protective film.
- 9) Please make it to the structure to suppress surroundings of the front polarizer for the display irregularity prevention.

15.3 Precautions for Operation

- 1) Since this TFT monitors are not equipped with light shielding for the driver IC, do not expose the driver IC to strong lights during operation as it may cause functional failures.
- 2) In case of powering up or powering off this LCD module, be sure to comply the sequence as instructed in this specification.
- 3) Optimize VCOMDC within recommended operating conditions.
* When VCOMDC is not an optimal value, flicker and image sticking will be occurred.
- 4) Do not plug in or out the FPC cable while power supply is switch on.
Plug the FPC cable in and out while power supply is switched off.
- 5) Do not operate the TFT monitors in the strong magnetic field. It may break the TFT monitors.
- 6) Do not display a fixed image on the screen for a long time.
Use a screen-saver or other measures to avoid a fixed image displayed on the screen for a long time.
Otherwise, it may cause burn-in image on the screen due the characteristics of liquid crystal.

15.4 Storage Condition for Shipping Cartons

Storage environment

- Temperature 0 to 40° C
- Humidity 60%RH or less
No-condensing occurs under low temperature with high humidity condition.
- Atmosphere No poisonous gas that can erode electronic components and/or wiring materials should be detected.
- Time period 3 months
- Unpacking To prevent damages caused by static electricity, anti-static precautionary measures (e.g. earthing, anti-static mat) should be implemented.
After unpack, keep product in the appropriate condition, otherwise bubble seal of Protective film may be printed on Polarizer.
- Maximum piling up 7 cartons

15.5 Precautions for Peeling off the Protective film

The followings work environment and work method are recommended to prevent the TFT monitors from static damage or adhesion of dust when peeling off the protective films.

A) Work Environment

- a) Humidity: 50 to 70 %RH, Temperature 15 to 27° C
- b) Operators should wear conductive shoes, conductive clothes, conductive finger tips and grounded wrist-straps. Anti-static treatment should be implemented to work area's floor.
- c) Use a room shielded against outside dust with sticky floor mat laid at the entrance to eliminate dirt.

B) Work Method

The following procedures should be taken to prevent the driver ICs from charging and discharging.

- a) Use an electrostatic neutralization blower to blow air on the TFT monitors to its lower right when FPC is placed at the right.

Optimize direction of the blowing air and the distance between the TFT monitors and the electrostatic neutralization blower.

- b) Put an adhesive tape (Scotch tape, etc) at the lower left corner area of the protective film to prevent scratch on surface of TFT monitors.
- c) Peel off the adhesive tape slowly (spending more than 2 secs to complete) by pulling it to opposite direction.

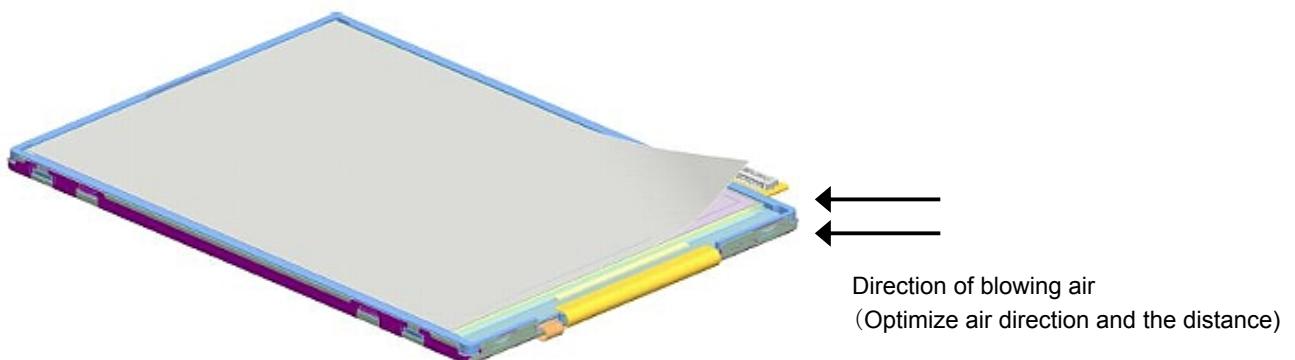

APPENDIX

Reference Method for Measuring Optical Characteristics and Performance

1. Measurement Condition (Backlight ON)

Measuring instruments: CS1000 (KONICA MINOLTA) , LCD7200(OTSUKA ELECTRONICS) ,EZcontrast160D (ELDIM)

Driving condition: Refer to the section "Optical Characteristics"

Measured temperature: 25° C unless specified

Measurement system: See the chart below. The luminance meter is placed on the normal line of measurement system.

Measurement point: At the center of the screen unless otherwise specified

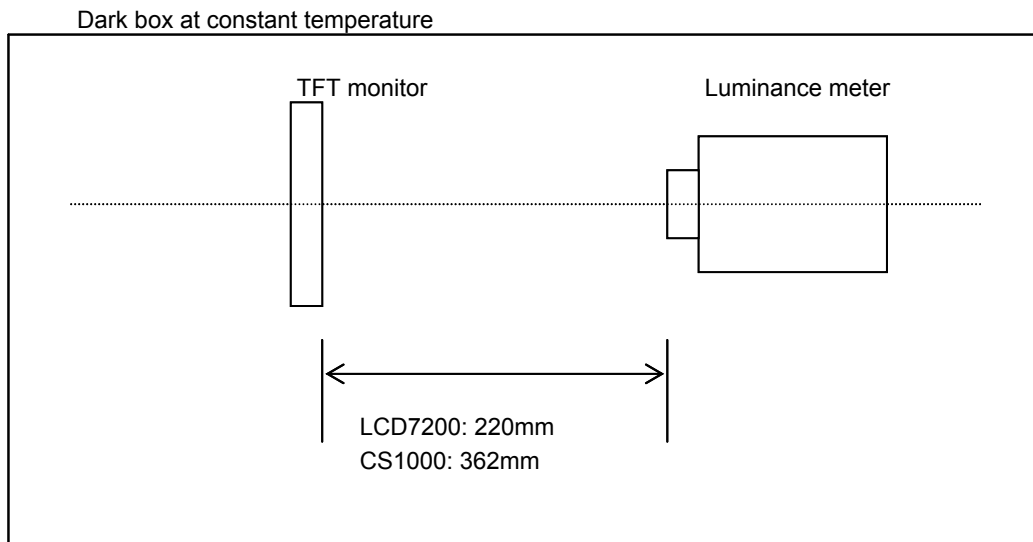

Measurement is made after 30 minutes of lighting of the backlight.

Measurement point: At the center point of the screen

Brightness distribution: 9 points shown in the following drawing.

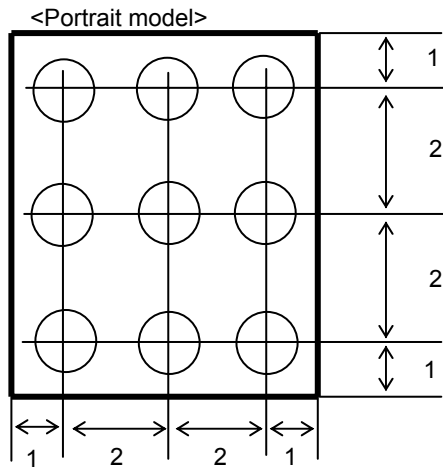

Dimensional ratio of active area

Backlight IL=20.0mA

Measurement Condition (Contrast ratio Backlight OFF only)

- Measuring instruments: LCD7200(OTSUKA ELECTRONICS),Ring Light(30,000lx,φ58)
- Driving condition: Refer to the section "Optical Characteristics"
- Measured temperature: 25° C unless specified
- Measurement system: See the chart below.
- Measurement point: At the center of the screen.

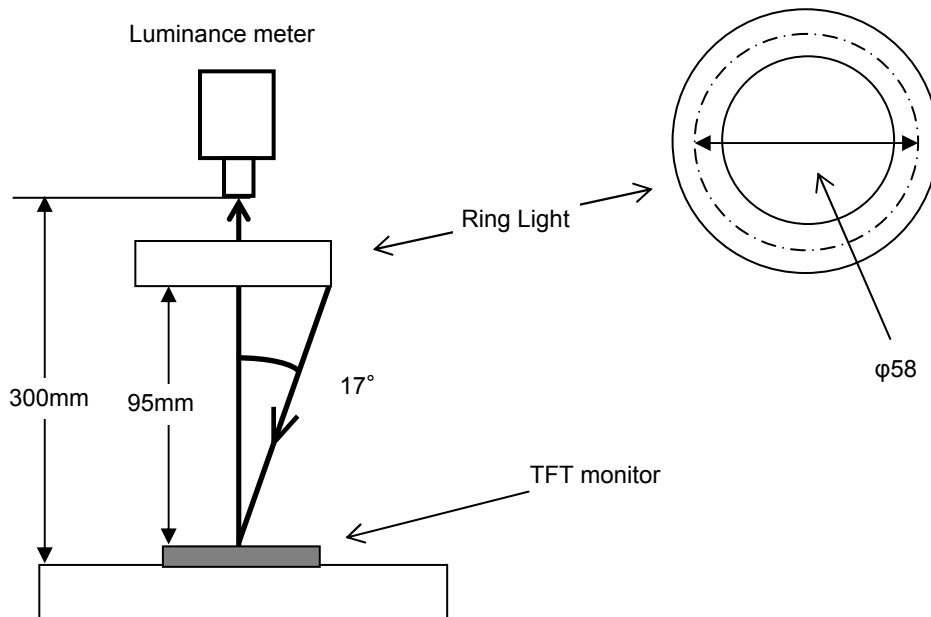

2. Test Method

Notice	Item	Test method	Measuring instrument	Remark
1	Response time	<p>Measure output signal waveform by the luminance meter when raster of window pattern is changed from white to black and from black to white.</p> <p style="text-align: center;">Black White Black</p> <p>White brightness</p> <p>100%</p> <p>90%</p> <p>10%</p> <p>0%</p> <p>Black brightness</p> <p>TON</p> <p>TOFF</p>	LCD7200	<p>Black display [Data]=00h</p> <p>White display [Data]=FFh</p> <p>TON</p> <p>Rise time</p> <p>TOFF</p> <p>Fall time</p>
2	Contrast ratio	<p>Measure maximum luminance Y1([Data]=FFh) and minimum luminance Y2([Data]=00h) at the center of the screen by displaying raster or window pattern. Then calculate the ratio between these two values.</p> <p style="text-align: center;">Contrast ratio = Y1/Y2</p> <p style="text-align: center;">Diameter of measuring point: 8mmφ</p>	CS1000 LCD7200	Backlight ON Backlight OFF
3	Viewing angle Horizontalθ Verticalφ	Move the luminance meter from right to left and up and down and determine the angles where contrast ratio is 10.	EZcontrast160D	
4	White chromaticity	<p>Measure chromaticity coordinates x and y of CIE1931 colorimetric system at [Data] = FFh</p> <p style="text-align: center;">Color matching faction: 2°view</p>	CS1000	
5	Burn-in	Visually check burn-in image on the screen after (2hours of "window display" ([Data]=FFh/00h).		At optimized VCOMDC
6	Center brightness	Measure the brightness at the center of the screen.	CS1000	
7	Brightness distribution	<p>(Brightness distribution) = 100 x B/A %</p> <p>A : max. brightness of the 9 points</p> <p>B : min. brightness of the 9 points</p>	CS1000	

Our company network supports you worldwide with offices in Germany, Austria, Switzerland, Great Britain and the USA. For more information please contact:

Headquarters

Germany



FORTEC Elektronik AG

Lechwiesenstr. 9
86899 Landsberg am Lech

Phone: +49 8191 91172-0
E-Mail: sales@forteca.de
Internet: www.forteca.de

Fortec Group Members

Austria



FORTEC Elektronik AG

Office Vienna

Nuschinggasse 12
1230 Wien

Phone: +43 1 8673492-0
E-Mail: office@fortec.at
Internet: www.fortec.at

Germany



Distec GmbH

Augsburger Str. 2b
82110 Germering

Phone: +49 89 894363-0
E-Mail: info@distec.de
Internet: www.distec.de

Switzerland



ALTRAC AG

Bahnhofstraße 3
5436 Würenlos

Phone: +41 44 7446111
E-Mail: info@altrac.ch
Internet: www.altrac.ch

United Kingdom



Display Technology Ltd.

5 The Oaks Business Village
Revenge Road, Lordswood
Chatham, Kent, ME5 8LF

Phone: +44 1634 62755
E-Mail: info@displaytechnology.co.uk
Internet: www.displaytechnology.co.uk

USA



Apollo Display Technologies, Corp.

87 Raynor Avenue,
Unit 1 Ronkonkoma,
NY 11779

Phone: +1 631 5804360
E-Mail: info@apolloDisplays.com
Internet: www.apolloDisplays.com