



OUR GLOBAL
COMPETENCE
CENTRES

 APOLLO DISPLAY
TECHNOLOGIES



 DISTEC



 DISPLAY
TECHNOLOGY



Datasheet

AUO

G170HAN01.1

UP-02-208



Product Specification

G170HAN01.1

AU OPTRONICS CORPORATION

(v) Preliminary Specifications

() Final Specifications

Module	17.0 Inch Color TFT-LCD
Model Name	G170HAN01.1

Customer	Date
_____	_____
Checked & Approved by	Date
_____	_____
Customer's sign back page	

Approved by	Date
Flossie Chuang	2020/04/20
Prepared by	Date
Nina ST Chang	2020/04/20
General Display Business Division / AU Optronics corporation	



Contents

- 1. Operating Precautions4**
- 2. General Description5**
 - 2.1 Display Characteristics..... 5
 - 2.2 Optical Characteristics 6
- 3. Functional Block Diagram9**
- 4. Absolute Maximum Ratings10**
 - 4.1 Absolute Ratings of TFT LCD Module..... 10
 - 4.2 Absolute Ratings of Environment..... 10
- 5. Electrical Characteristics11**
 - 5.1 TFT LCD Module and Backlight Unit..... 11
- 6. Signal Characteristic15**
 - 6.1 Pixel Format Image..... 15
 - 6.2 Scanning Direction 15
 - 6.3 Signal Description 16
 - 6.4 Interface Timing 18
 - 6.5 Power ON/OFF Sequence 19
- 7. Connector & Pin Assignment.....20**
 - 7.1 TFT LCD Module: eDP Connector 20
- 8. Reliability Test Criteria21**
- 9. Mechanical Characteristics.....22**
 - 9.1 LCM Outline Dimension22**
- 10. Label and Packaging23**
 - 10.1 Shipping Label (on the rear side of TFT-LCD display) 23
 - 10.2 Carton Package 23
- 11 Safety24**
 - 11.1 Sharp Edge Requirements 25
 - 11.2 Materials..... 25
 - 11.3 Capacitors 25
 - 11.4 National Test Lab Requirement 25



Product Specification

G170HAN01.1

AU OPTRONICS CORPORATION

Record of Revision

Version	Date (yyyy/m/d)	Page	Old description	New Description
0.1	2020.04.20	All	Preliminary specification	

AUO Confidential
For DISTEC Internal Use Only
20200622 21:59:55

AUO Confidential
For DISTEC Internal Use Only
20200622 21:59:55

AUO Confidential
For DISTEC Internal Use Only
20200622 21:59:55

AUO Confidential
For DISTEC Internal Use Only
20200622 21:59:55

1. Operating Precautions

- 1) Since polarizer is easily damaged, do not touch or press the surface of polarizer with hand.
- 2) Be sure to turn off power supply when inserting or disconnecting from input connector.
- 3) When the panel surface is soiled, use special screen cleaning roller to clean. Do not use anything to wipe panel surface. (ex : absorbent cotton, soft cloth, any solution...). If the surface is contaminated by solution, cover absorbent cotton or other soft cloth to adsorption the solution.
- 4) Since the panel is made of glass, it may break or crack if dropped or bumped on hard surface.
- 5) Since CMOS LSI is used in this module, take care of static electricity and insure human earth when handling.
- 6) Do not open or modify the Module Assembly.
- 7) Do not press the reflector sheet at the back of the module to any directions.
- 8) In case if a TFT-LCD Module has to be put back into the packing container slot after once it was taken out from the container, do not press the center of the LED lightbar edge. Otherwise the TFT-LCD Module may be damaged.
- 9) Insert or pull out the interface connector, be sure not to rotate nor tilt it of the TFT-LCD Module.
- 10) Do not twist nor bend the TFT -LCD Module even momentary. It should be taken into consideration that no bending/twisting forces are applied to the TFT-LCD Module from outside. Otherwise the TFT-LCD Module may be damaged.
- 11) Small amount of materials having no flammability grade is used in the LCD module. The LCD module should be supplied by power complied with requirements of Limited Power Source (IEC60950 or UL1950), or be applied exemption.
- 12) Please avoid touching COF position while you are doing mechanical design.
- 13) When storing modules as spares for a long time, the following precaution is necessary: Store them in a dark place. Do not expose the module to sunlight or fluorescent light. Keep the temperature between 5°C and 35°C at normal humidity.
- 14) Severe temperature condition may result in different luminance, response time and LED life time.
- 15) The data on this specification sheet is applicable when LCD module is placed in landscape position.
- 16) Continuous displaying fixed pattern may induce image sticking. It is recommended to use screen saver or shuffle content periodically if fixed pattern is displayed on the screen.
- 17) When this reverse-type model(PCBA on bottom side) is used as forward-type model(PCBA on top side) , AUO can not guarantee any defects of LCM .

2. General Description

This specification applies to the 17 inch square Color TFT-LCD Module G170HAN01.1. The display supports the resolution - 1920(H) x 1920(V) and 16.7M colors (RGB 8-bits data). All input signals are 4 lanes eDP (1.3) interface. LED driver board is included.

2.1 Display Characteristics

The following items are characteristics summary on the table under 25 °C condition:

ITEMS	Unit	SPECIFICATIONS
Screen Diagonal	[mm]	431.67(17.0")
Active Area	[mm]	305.28(H) x 305.28(V)
Pixels H x V		1920(xRGB) x 1920
Pixel Pitch	[mm]	0.159 (per one triad) x0.159
Pixel Arrangement		R.G.B. Vertical Stripe
Display Mode		AHVA Mode, Normally Black
White Luminance (Center)	[cd/m ²]	350 (Typ.)
Contrast Ratio		1000: 1
Optical Response Time	[msec]	25 (On/Off, Typ.)
Nominal Input Voltage VDD	[Volt]	12
Power Consumption	[Watt]	15.36 (Typ.)
Weight	[g]	1200g (Max.)
Physical Size	[mm]	325.01(H) x 319.33(V) x 11.93(D) (Typ.)
Electrical Interface		4 lanes eDP (1.3)
Support Color		16.7M colors (true 8-bit)
Surface Treatment		Anti-Glare, Anti-Reflection, 2H
Temperature Range		
Operating	[°C]	-20 to +60
Storage (Shipping)	[°C]	-20 to +70
RoHS Compliance		RoHS Compliance

2.2 Optical Characteristics

The optical characteristics are measured under stable conditions at 25 °C (Room Temperature):

Item	Unit	Conditions	Min.	Typ.	Max.	Note
Central Luminance	[cd/m ²]	I _F = 47 mA	280	350	-	1
Uniformity	%	5 Points	75	80	-	1, 2, 3
Contrast Ratio			600	1000	-	4
Response Time	[msec]	Rising	-	13	23	5
		Falling	-	12	22	
		Rising + Falling	-	25	45	
Viewing Angle	[degree]	Horizontal (Right) CR = 10 (Left)	85	89	-	6
	[degree]		85	89	-	
	[degree]	Vertical (Upper) CR = 10 (Lower)	85	89	-	
	[degree]		85	89	-	
Color / Chromaticity Coordinates (CIE 1931)		Red x	-0.05	0.634	+0.05	
		Red y		0.333		
		Green x		0.305		
		Green y		0.612		
		Blue x		0.154		
		Blue y		0.060		
		White x		0.313		
		White y		0.329		
Color Gamut	%			72	-	

Note 1: Measurement method

Equipment Pattern Generator, Power Supply, Digital Voltmeter, Luminance meter (SR_3 or equivalent)

Aperture 1° with 50cm viewing distance

Test Point Center

Environment < 1 lux

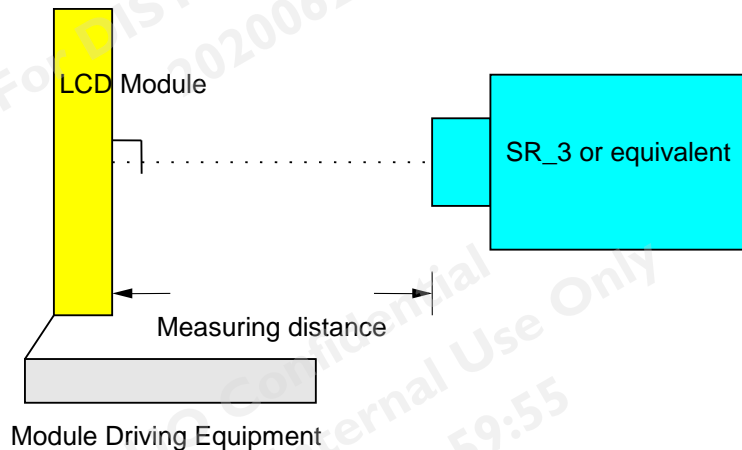

Note 2: Definition of 5 points position. Display active area

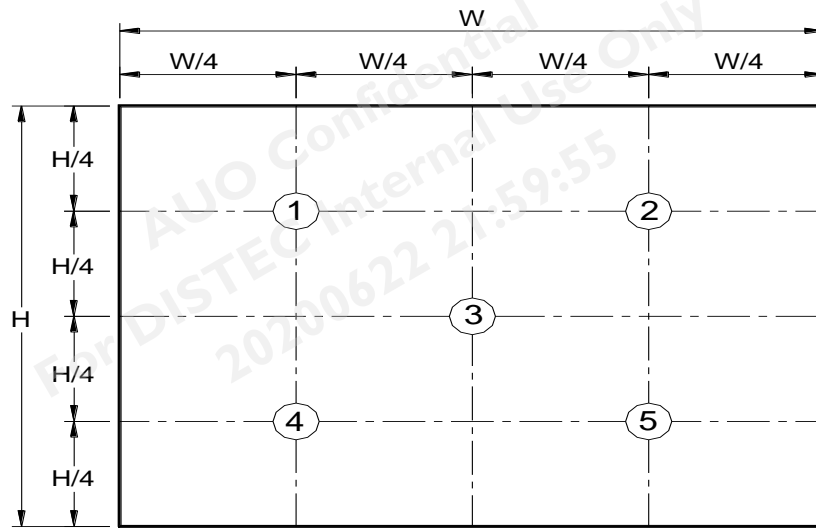

Note 3: The luminance uniformity of 5 points is defined by dividing the minimum luminance values by the maximum test point luminance

$$\delta_{w5} = \frac{\text{Minimum Brightness of five points}}{\text{Maximum Brightness of five points}}$$

Note 4: Definition of contrast ratio (CR):

$$\text{Contrast ratio (CR)} = \frac{\text{Brightness on the "White" state}}{\text{Brightness on the "Black" state}}$$

Note 5: Definition of response time:

The output signals of photo detector are measured when the input signals are changed from "White" to "Black" (falling time) and from "Black" to "White" (rising time), respectively. The response time interval is between 10% and 90% of amplitudes. Please refer to the figure as below.

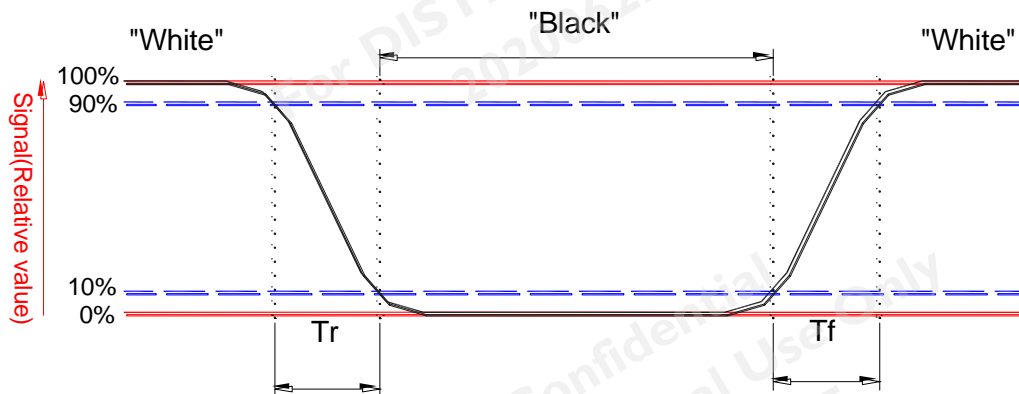

Note 6: Definition of viewing angle

Viewing angle is the measurement of contrast ratio ≥ 10 , at the screen center, over a 180° horizontal and 180°

vertical range (off-normal viewing angles). The 180° viewing angle range is broken down as below: 90° (θ) horizontal left and right, and 90° (Φ) vertical high (up) and low (down). The measurement direction is typically perpendicular to the display surface with the screen rotated to its center to develop the desired measurement viewing angle.

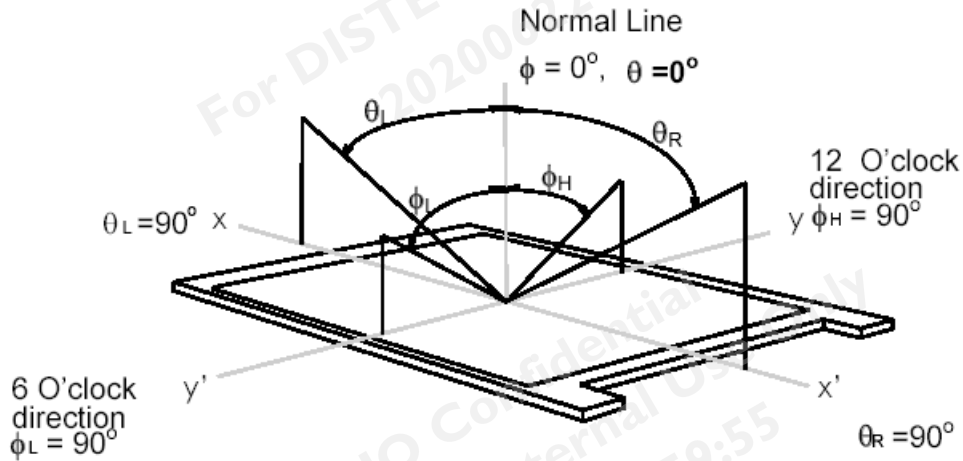

3. Functional Block Diagram

The following diagram shows the functional block of the 17.0 inch color TFT/LCD module:

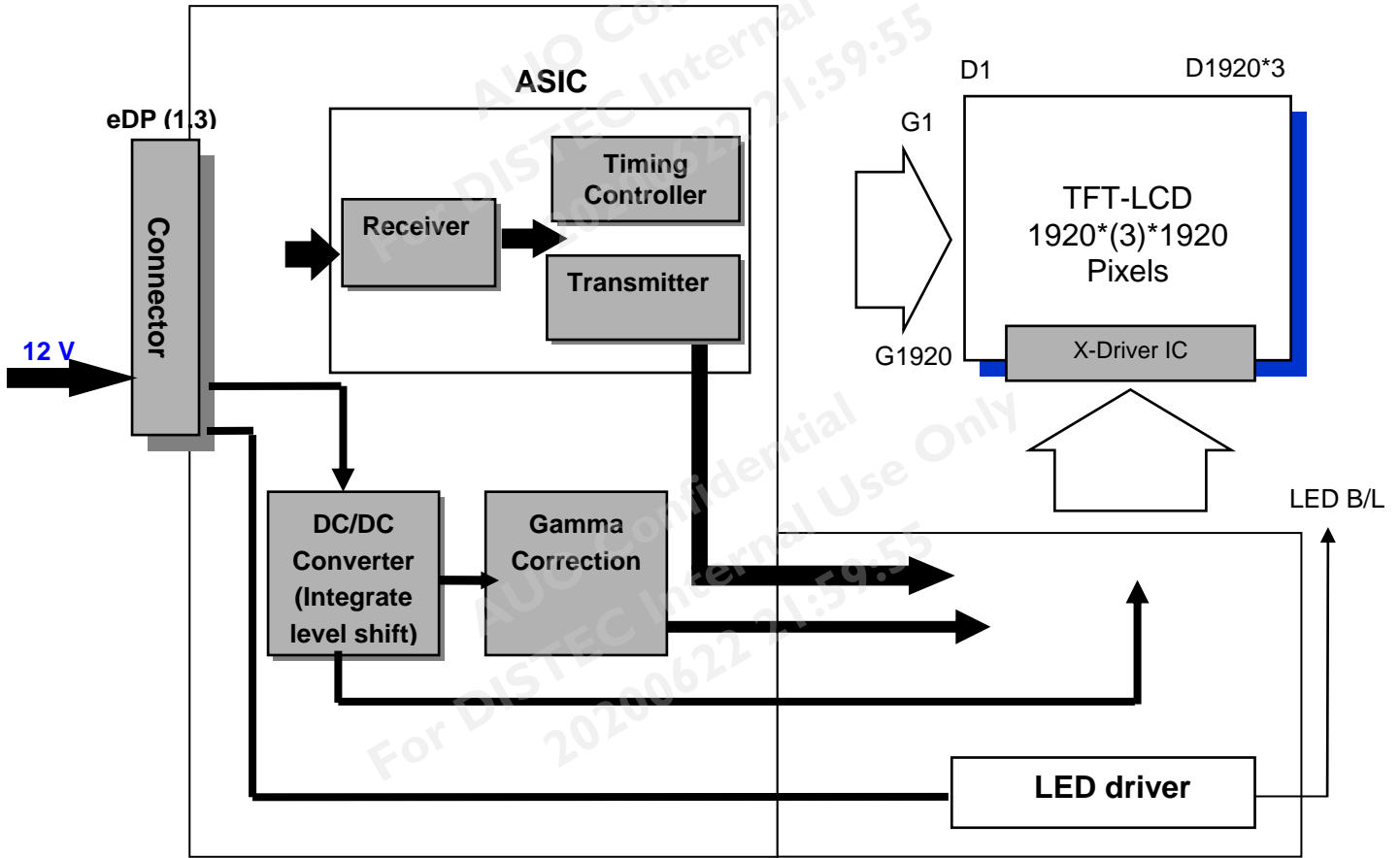

4. Absolute Maximum Ratings

4.1 Absolute Ratings of TFT LCD Module

Item	Symbol	Min	Max	Unit
Logic/LCD drive Voltage	Vin	10.8	13.2	[Volt]

4.3 Absolute Ratings of Environment

Item	Symbol	Min	Max	Unit
Operating Temperature	TOP	-20	60	[°C]
Operation Humidity	HOP	5	90	[%RH]
Storage Temperature	TST	-20	70	[°C]
Storage Humidity	HST	5	90	[%RH]

Note 1: With in Ta (25°C)

Note 2: Permanent damage to the device may occur if exceeding maximum values

Note 3: Temperature and relative humidity range are shown as following.

1. 95% RH Max (Ta ≤ 39 °C)
2. Max wet-bulb temperature at 39°C or less. (Ta ≤ 39 °C)
3. No condensation

Note 4: Function Judged only

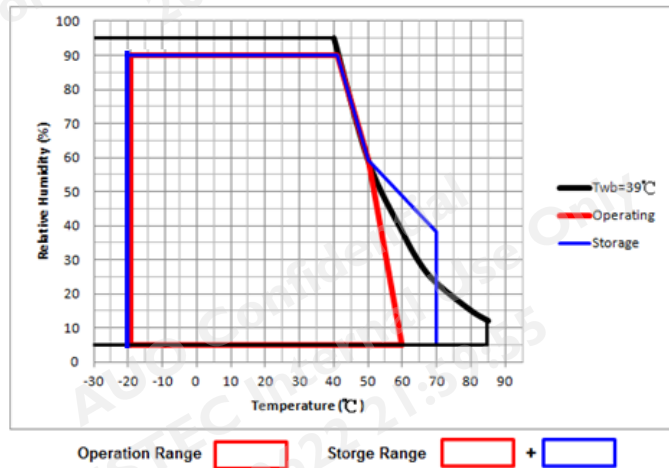

5. Electrical Characteristics

5.1 TFT LCD Module and Backlight Unit

5.1.1 Power Specification

Following characteristics are measured under stable condition at 25°C (Room Temperature).

Symbol	Parameter	Min	Typ	Max	Units	Remark
VDD	Input Voltage	10.8	12	13.2	Volt	
IDD	Input Current	-	1.28	-	A	VDD=12V, All White Pattern AT 60Hz
PDD	Power Consumption		15.36	16.896	Watt	VDD=12V, All White Pattern AT 60Hz
Irush	Inrush Current	-	-	3	A	Note 4
BL_EN	On Control Voltage	1.8	-	-	Volt	
	Off Control Voltage	-	-	0.6	Volt	
PWM	PWM Dimming Frequency	10K	-	20K	Hz	
	Swing Voltage	3	3.3	3.6	Volt	
	Dimming Duty Cycle	5	-	100	%	
I _F	LED Forward Current		47		mA	Ta = 25°C
LTLED	LED Life Time	50,000	-	-	Hrs	Note 4

Note 1: Ta means ambient temperature of TFT-LCD module,

Note 2: If module is driven by high current or at high ambient temperature & humidity condition. The operating life will be reduced.

Note 3: LED light bar structure: (6 strings x 10 pcs / string =60 pcs LED)

Note 4: Definition of life time: Brightness becomes to 50% of its original value. The minimum life time of LED unit is on the condition of I_F = 58 mA and 25±2°C (Room Temperature).

Note 5: Measurement condition:

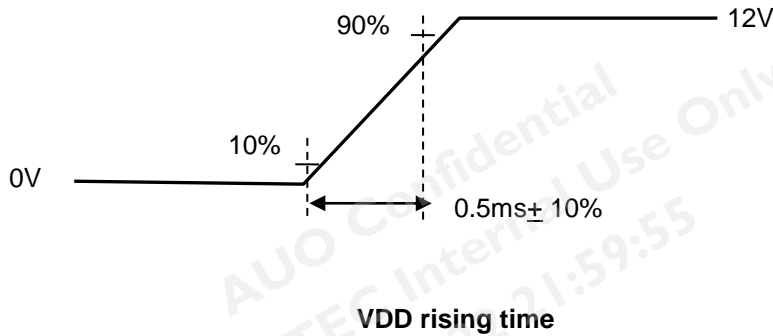
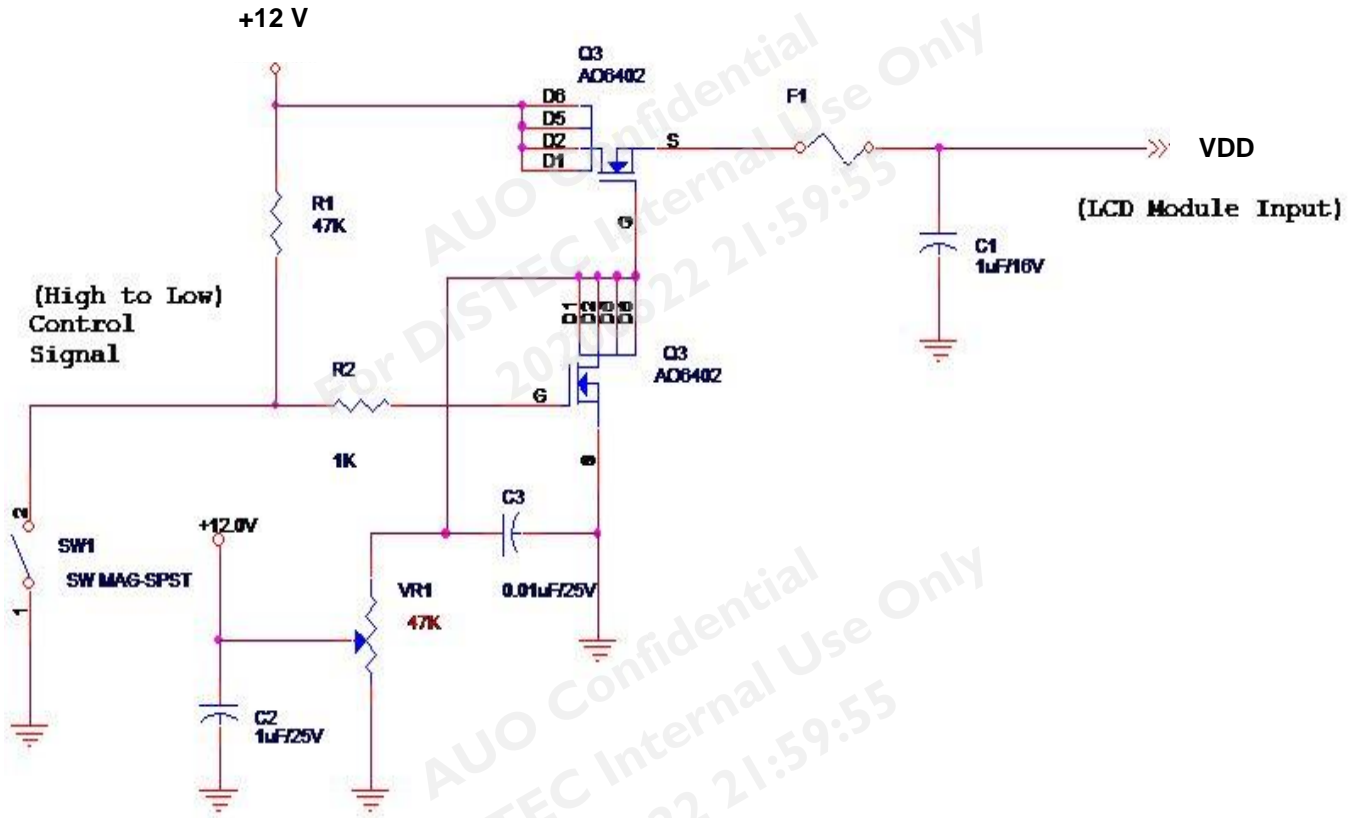

5.1.2 Signal Electrical Characteristics

Input signals shall be low or High-impedance state when VDD is off. Signal electrical characteristics are as follows;

Display Port main link signal:

Differential pair VD+ , VD-
Which is one Display port
Main link

VCM of Display port
Main link

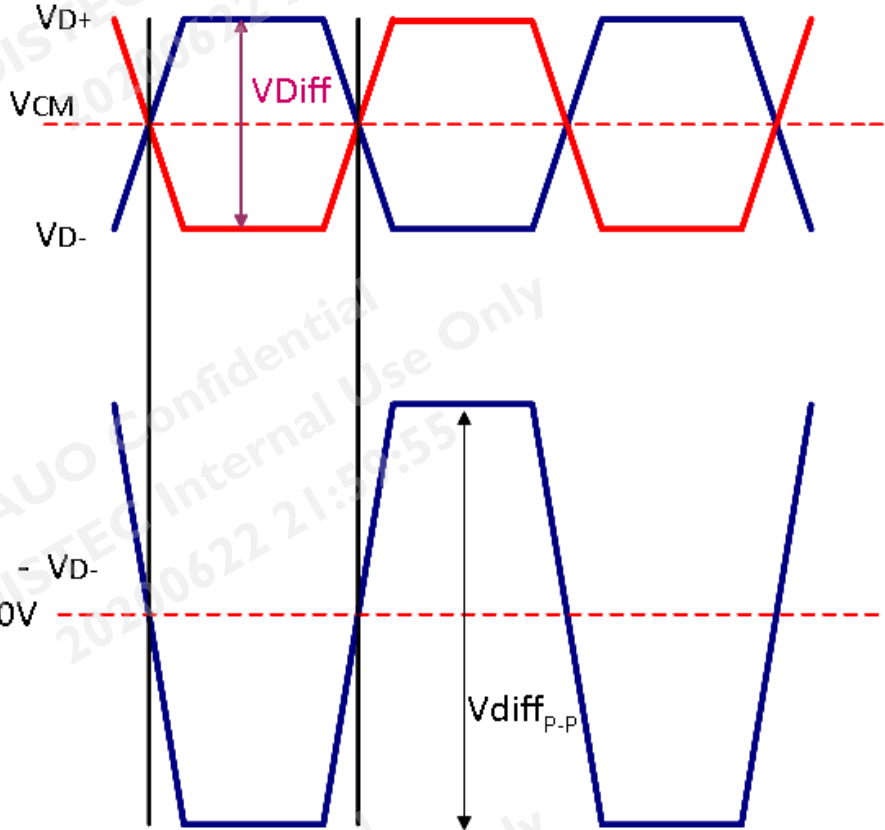

$$V_{diff_{p-p}} = [(VD+) - (VD-)] \times 2$$

$$V_{D+} - V_{D-}$$

0V

Display port main link					
		Min	Typ	Max	unit
VCM	RX input DC Common Mode Voltage		0		V
VDiff _{p-p}	Peak-to-peak Voltage at a receiving Device	120		1320	mV

Follow as VESA display port standard V1.1a.

Display Port AUX_CH signal:

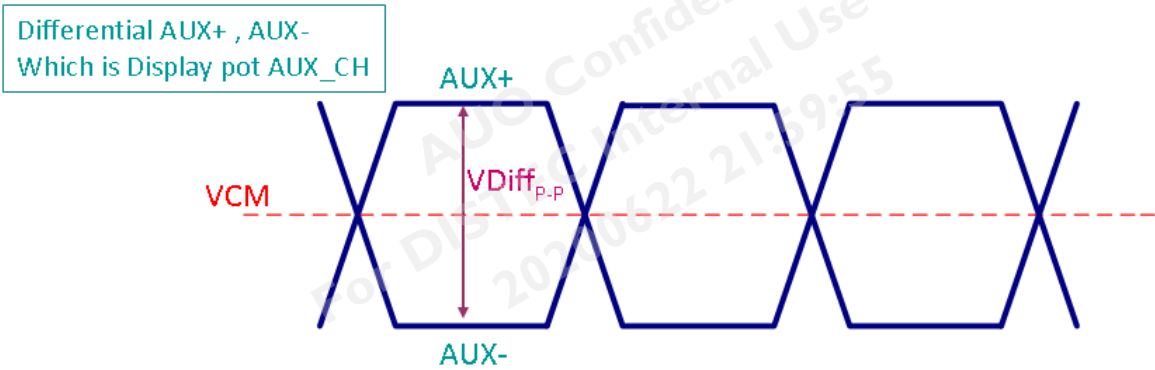

Display port AUX_CH					
		Min	Typ	Max	unit
VCM	AUX DC Common Mode Voltage		0		V
VDiff _{P-P}	AUX Peak-to-peak Voltage at a receiving Device	0.4	0.6	0.8	V

Follow as VESA display port standard V1.1a.

Display Port VHPD signal:

Display Port VHPD					
		Min	Typ	Max	unit
VHPD	HPD voltage	2.25		3.6	V

Follow as VESA display port standard V1.1a.

6. Signal Characteristic

6.1 Pixel Format Image

Following figure shows the relationship between input signal and LCD pixel format.

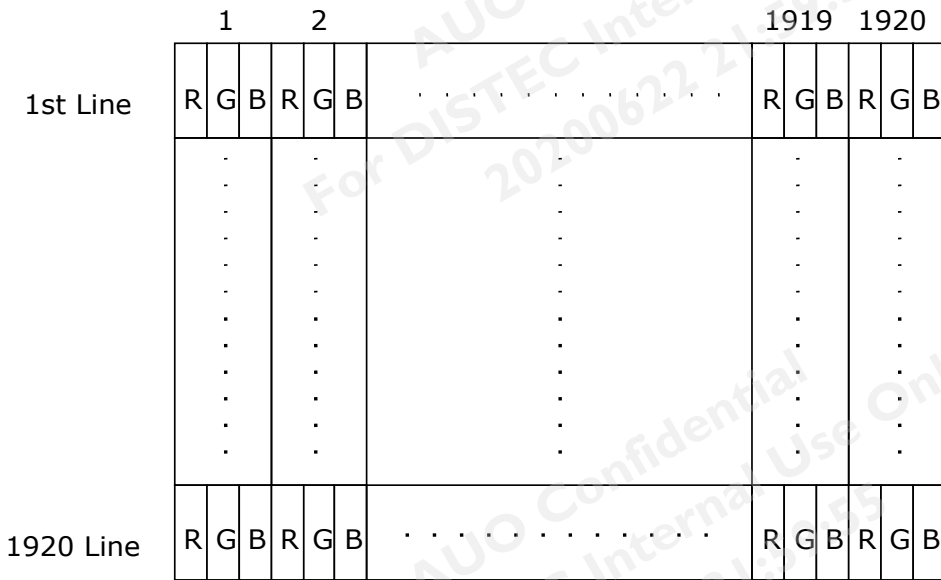

6.2 Scanning Direction

The following figures show the image seen from the front view. The arrow indicates the direction of scan.

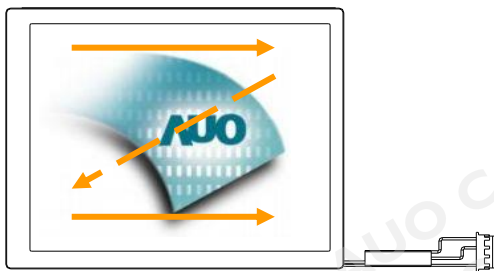

Fig. 1 Normal scan (Pin4, DPS = Low or NC)

6.3 Signal Description

The module uses a LVDS receiver embedded in AUO's ASIC. LVDS is a differential signal technology for LCD interface and a high-speed data transfer device.

PIN #	SIGNAL NAME	DESCRIPTION
1	NC	NC
2	GND	Ground
3	Lane3_N	Signal Link Lane 3_N
4	Lane3_P	Signal Link Lane 3_P
5	GND	Ground
6	Lane2_N	Signal Link Lane 2_N
7	Lane2_P	Signal Link Lane 2_P
8	GND	Ground
9	Lane1_N	Signal Link Lane 1_N
10	Lane1_P	Signal Link Lane 1_P
11	GND	Ground
12	Lane0_N	Signal Link Lane 0_N
13	Lane0_P	Signal Link Lane 0_P
14	GND	Ground
15	AUX_CH_P	Signal Auxiliary Channel P
16	AUX_CH_N	Signal Auxiliary Channel N
17	GND	Ground
18	NC	NC
19	NC	NC
20	NC	NC
21	NC	NC
22	BIST	BIST
23	GND	Ground
24	GND	Ground
25	GND	Ground
26	GND	Ground
27	HPD	HPD signal pin
28	GND	Ground
29	GND	Ground
30	GND	Ground
31	GND	Ground
32	LED_EN	Backlight ON/OFF
33	LED_PWM	System PWM signal input for dimming
34	NC-Reserved	Reserved for LCD manufacture's use(EDID_CLK)
35	NC-Reserved	Reserved for LCD manufacture's use(EDID_DATA)

36	VDD	LCD logic and Backlight power(+12V)
37	VDD	LCD logic and Backlight power(+12V)
38	VDD	LCD logic and Backlight power(+12V)
39	VDD	LCD logic and Backlight power(+12V)
40	NC	NC

Note: "Power Ground" stands for 0V.

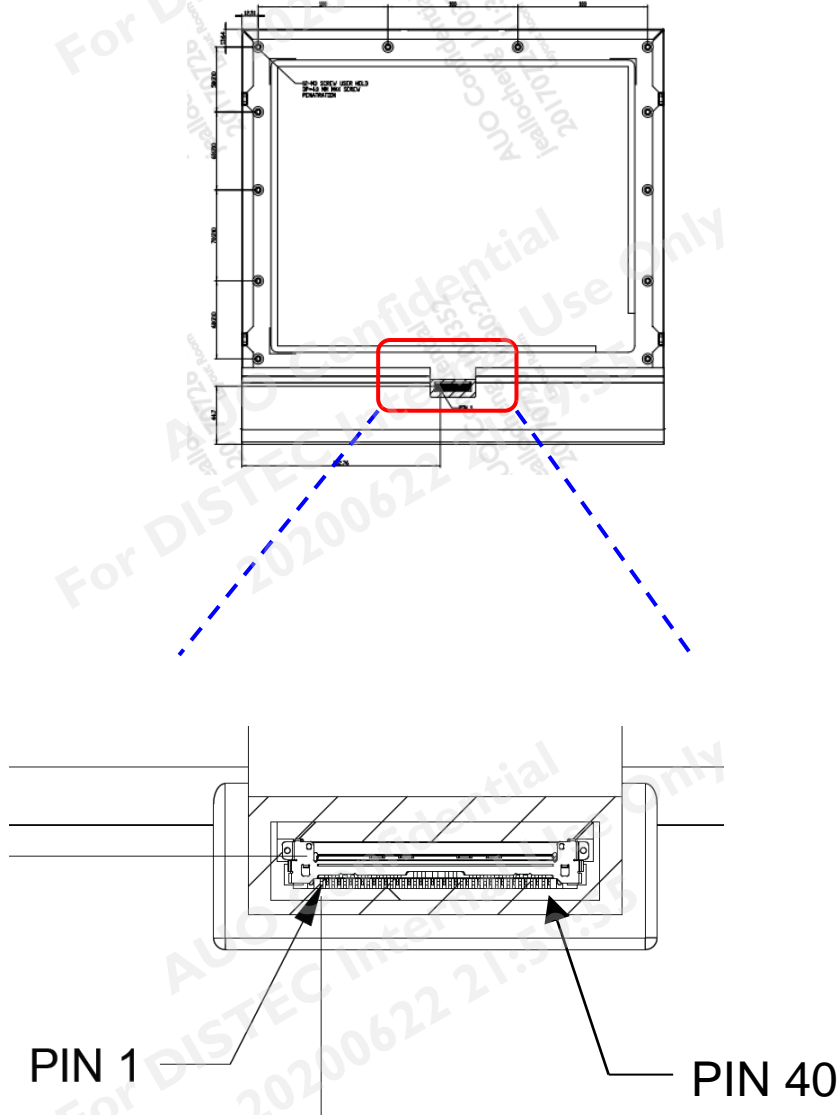

6.4 Interface Timing

6.4.1 Timing Characteristics

Signal	Symbol	Min.	Typ.	Max.	Unit
Clock Frequency	$1/T_{\text{Clock}}$	-	247	-	MHz
Vertical Section	Period	T_V	1969	-	T_{Line}
	Active	T_{VD}	1920	-	
	Blanking	T_{VB}	49	-	
Horizontal Section	Period	T_H	2104	-	T_{Clock}
	Active	T_{HD}	1920	-	
	Blanking	T_{HB}	184	-	
Frame Rate	F	59	60	61	Hz

Note : DE mode only.

6.4.2 Input Timing Diagram

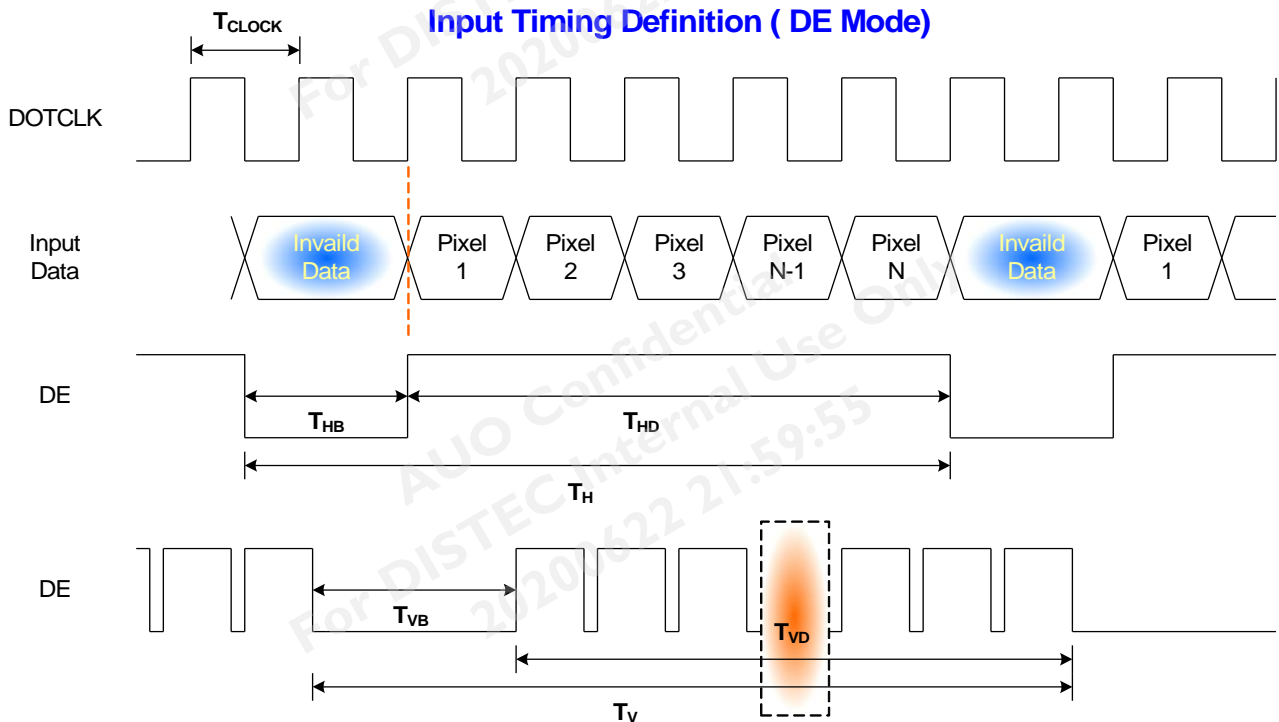

6.5 Power ON/OFF Sequence

VDD power and lamp on/off sequence is as below. Interface signals are also shown in the chart. Signals from any system shall be Hi-Z state or low level when VDD is off.

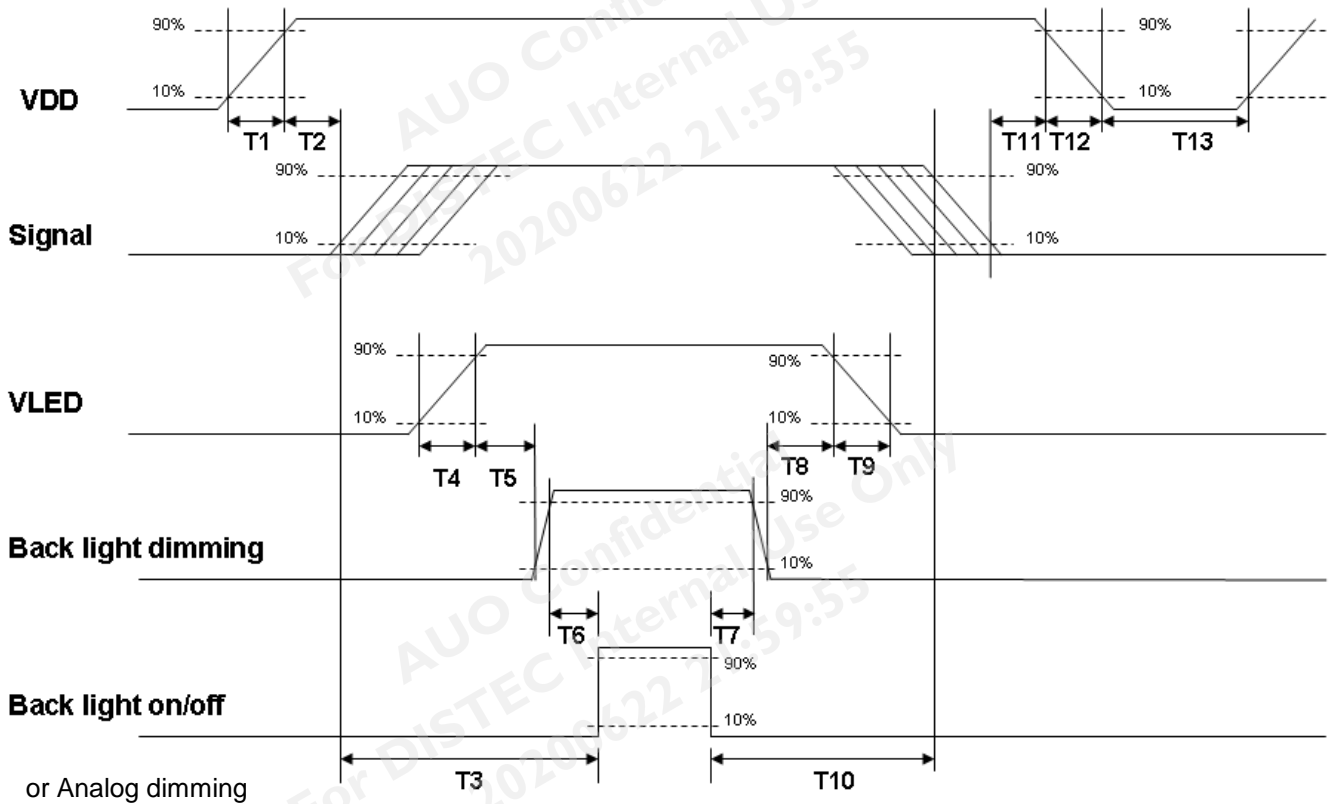

Power ON/OFF sequence timing

Parameter	Value			Units
	Min.	Typ.	Max.	
T1	0.5	-	10	[ms]
T2	30	40	50	[ms]
T3	200	-	-	[ms]
T6	10	-	-	[ms]
T7	0	-	-	[ms]
T10	110	-	-	[ms]
T11	0	16	50	[ms]
T12	0	-	10	[ms]
T13	1000	-	-	[ms]

The above on/off sequence should be applied to avoid abnormal function in the display. Please make sure to turn off the power when you plug the cable into the input connector or pull the cable out of the connector.

7. Connector & Pin Assignment

Physical interface is described as for the connector on module. These connectors are capable of accommodating the following signals and will be following components.

7.1 TFT LCD Module: eDP Connector

Connector Name / Designation	Interface Connector / Interface card
Manufacturer	JAE or compatible
Type Part Number	HD1S040HA1 or equivalent.
Mating Housing Part Number	HD1P040MA1 or compatible

AUO Confidential
For DISTEC Internal Use Only
20200622 21:59:55

AUO Confidential
For DISTEC Internal Use Only
20200622 21:59:55

AUO Confidential
For DISTEC Internal Use Only
20200622 21:59:55

8. Reliability Test Criteria

Items	Required Condition	Note
Temperature Humidity Bias	Ta= 50°C, 80%RH, 300hours	
High Temperature Operation	Ta= 60°C, 300hours	
Low Temperature Operation	Ta= -20°C, 300hours	
Hot Storage	Ta= 70°C, 300hours	
Cold Storage	Ta= -20°C, 300hours	
Thermal Shock Test	-20 °C /30 min ,60 °C /30 min ,100cycles	
Shock Test (Non-Operating)	Acceleration: 50 G Wave: Half-sine Active Time: 20 ms Direction: ±X, ±Y, ±Z (one time for each Axis)	
Vibration Test (Non-Operating)	Acceleration: 1.5 Grms Wave: Random Frequency: 10 - 200 Hz Duration: 30 Minutes each Axis (X, Y, Z)	
On/off test	On/10 sec, Off/10 sec, 30,000 cycles	
ESD	Contact Discharge: ± 8 KV, 150pF(330Ω) 1sec, 8 points, 25 times/ point., Class B	1
	Air Discharge: ± 15 KV, 150pF(330Ω) 1sec, 8 points, 25 times/ point., Class B	

Note 1: According to EN61000-4-2, ESD class B: Some performance degradation allowed. No data lost
Self-recoverable. No hardware failures.

Note2:

- Water condensation is not allowed for each test items.
- Each test is done by new TFT-LCD module. Don't use the same TFT-LCD module repeatedly for reliability test.
- The reliability test is performed only to examine the TFT-LCD module capability.
- To inspect TFT-LCD module after reliability test, please store it at room temperature and room humidity for 24 hours at least in advance.
- No function failure occurs.

10. Label and Packaging

10.1 Shipping Label (on the rear side of TFT-LCD display)

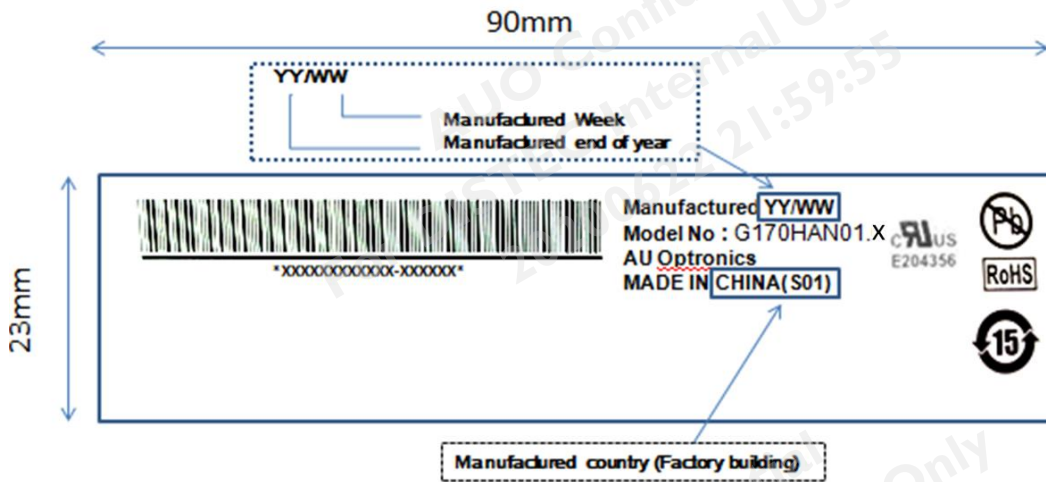

10.2 Carton Package

- Max capacity : 10 TFT-LCD module per carton
- Max weight: 15 kg per carton
- Outside dimension of carton: 508mm(L)* 408mm(W)*279mm(H)
- Pallet size : 1150 mm * 840mm * 132mm

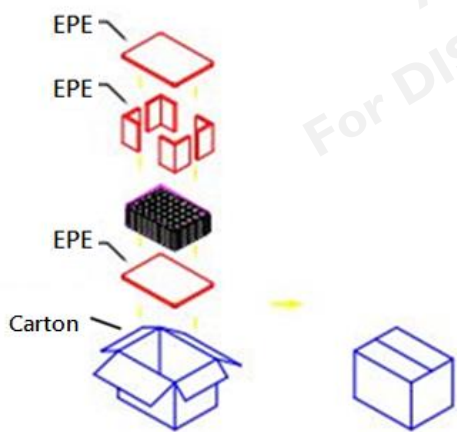
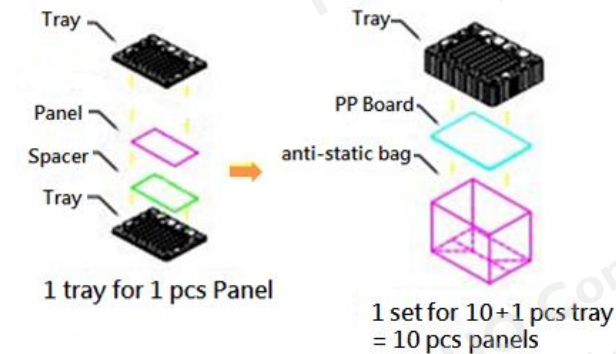



Place PP board

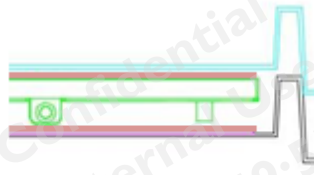

1 tray contains 1pc module and 2pcs EPE (Top & Bot.).

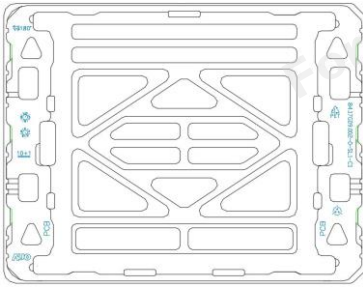
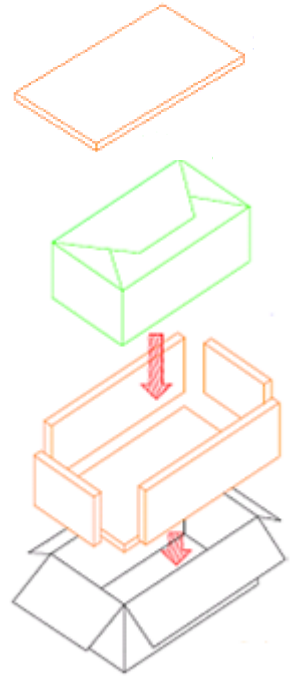

Place tray on the PP board.

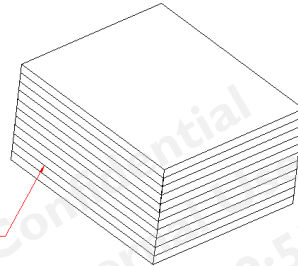

11tray

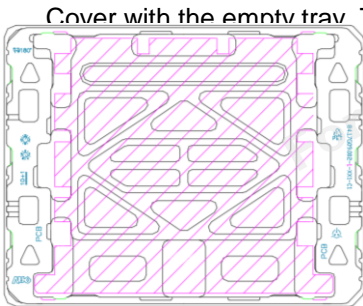

Cover with the empty tray. The (+1) tray should be

Place the EPE around the package.

Put 1pc EPE spacer into the tray.



Seal the carton with packing tape.

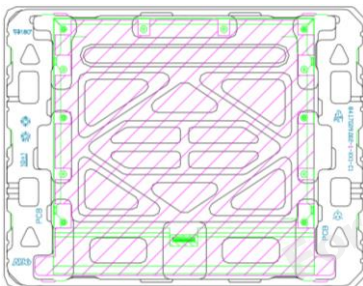

Put 1pc module on EPE.



Put the package into the Antistatic Bag.
Pack the bag and tape the bag with scotch tape.



11 Safety

11.1 Sharp Edge Requirements

There will be no sharp edges or comers on the display assembly that could cause injury.

11.2 Materials

11.2.1 Toxicity

There will be no carcinogenic materials used anywhere in the display module. If toxic materials are used, they will be reviewed and approved by the responsible AUO toxicologist.

11.2.2 Flammability

All components including electrical components that do not meet the flammability grade UL94-V1 in the module will complete the flammability rating exception approval process.

The printed circuit board will be made from material rated 94-V1 or better. The actual UL flammability rating will be printed on the printed circuit board.

11.3 Capacitors

If any polarized capacitors are used in the display assembly, provisions will be made to keep them from being inserted backwards.

11.4 National Test Lab Requirement

The display module will satisfy all requirements for compliance to:

UL 60950-1, Second Edition

U.S.A. Information Technology Equipment

Our company network supports you worldwide with offices in Germany, Austria, Switzerland, the UK and the USA. For more information please contact:

Headquarters

Germany



FORTEC Elektronik AG

Augsburger Str. 2b
82110 Germering

Phone: +49 89 894450-0
E-Mail: info@fortecag.de
Internet: www.fortecag.de

Fortec Group Members

Austria



Distec GmbH Office Vienna

Nuschinggasse 12
1230 Wien

Phone: +43 1 8673492-0
E-Mail: info@distec.de
Internet: www.distec.de

Germany



Distec GmbH

Augsburger Str. 2b
82110 Germering

Phone: +49 89 894363-0
E-Mail: info@distec.de
Internet: www.distec.de

Switzerland



ALTRAC AG

Bahnhofstraße 3
5436 Würenlos

Phone: +41 44 7446111
E-Mail: info@altrac.ch
Internet: www.altrac.ch

United Kingdom



Display Technology Ltd.

Osprey House, 1 Osprey Court
Hichingbrooke Business Park
Huntingdon, Cambridgeshire, PE29 6FN

Phone: +44 1480 411600
E-Mail: info@displaytechnology.co.uk
Internet: www.displaytechnology.co.uk

USA



Apollo Display Technologies, Corp.

87 Raynor Avenue,
Unit 1 Ronkonkoma,
NY 11779

Phone: +1 631 5804360
E-Mail: info@apolloDisplays.com
Internet: www.apolloDisplays.com