



OUR GLOBAL
COMPETENCE
CENTRES

 APOLLO DISPLAY
TECHNOLOGIES



 DISTEC



 DISPLAY
TECHNOLOGY



Datasheet

Distec

DD-0700!AE11

88 !\$/005

PRODUCT SPECIFICATIONS(Preliminary)

For Customer: _____

: APPROVAL FOR SPECIFICATION

Customer Model No. _____

: APPROVAL FOR SAMPLE

Module No.: DD-0700-ME11

Date : 2021-03-03

Table of Contents

No.	Item	Page
1	Cover Sheet(Table of Contents)	P3
2	Revision Record	P4
3	General Specifications	P5
4	Outline Drawing	P6
5	Absolute Maximum Ratings	P7
6	Electrical Specifications	P8-P16
7	Optical Characteristics	P17-P20
8	Reliability Test Items and Criteria	P21
9	Precautions for Use of LCD Modules	P22-P23

For Customer's Acceptance:

Approved By	Comment

PREPARED	CHECKED	VERIFIED BY QA DEPT	VERIFIED BY R&D DEPT
LC			

2. Revision Record

Date	Rev.No.	Page	Revision Items	Prepared
2021.03.03	V0		The first release	LC

3. General Specifications

DD-0700-ME11 is a TFT-LCD module. It is composed of a TFT-LCD panel, driver IC, FPC, a back light and PCB unit . The 7.0" display area contains 800 x (RGB) x 480 pixels and can display up to 16.7M colors. This product is RoHS compliant.

Item	Contents	Unit	Note
LCD Type	TFT	-	
Display color	16.7M		1
Viewing Direction	ALL	O'Clock	
Display Mode	Transmissive, Normally Black		
Operating temperature	-30 ~ +80	°C	
Storage temperature	-30 ~ +80	°C	
Module size	169.80 x 109.70 x 8.90	mm	2
Active Area(W×H)	152.40 x 91.44	mm	
Number of Dots	800 x 480	dots	
TFT Driver IC	HX8290-A-LT & HX8664-B-LT	-	
Power Supply Voltage	3.3	V	
Weight	-	g	
Interface	LVDS	-	
Surface treatment	Anti-Glare and hard-coating 3H		

Note 1: Color tune is slightly changed by temperature and driving voltage.

Note 2: Without FPC and Solder. With PCB.

4.Outline.Drawing

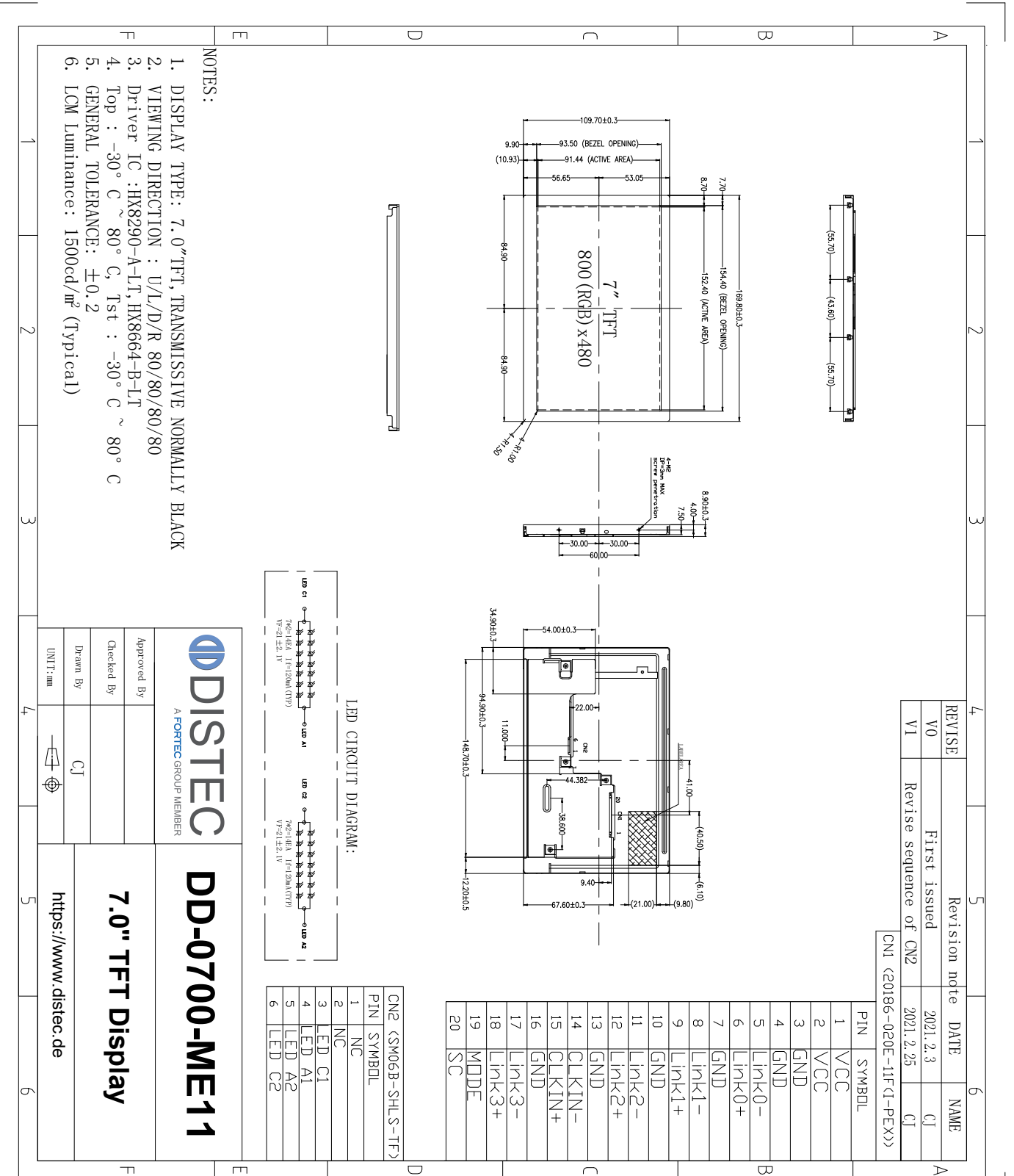

5. Absolute Maximum Ratings($T_a=25\text{ }^\circ\text{C}$)

5.1 Electrical Absolute Maximum Ratings.($V_{SS}=0V, T_a=25\text{ }^\circ\text{C}$)

Item	Symbol	Min.	Max.	Unit	Note
Power Supply Voltage	VCC	-0.3	4.0	V	1, 2

Notes:

1. If the module is above these absolute maximum ratings. It may become permanently damaged. Using the module within the following electrical characteristic conditions are also exceeded, the module will malfunction and cause poor reliability.

2. $V_{CC} > V_{SS}$ must be maintained.

3. Please be sure users are grounded when handing LCD Module.

5.2 Environmental Absolute Maximum Ratings.

Item	Storage		Operating		Note
	MIN.	MAX.	MIN.	MAX.	
Ambient Temperature	-30 $^\circ\text{C}$	80 $^\circ\text{C}$	-30 $^\circ\text{C}$	80 $^\circ\text{C}$	1,2
Humidity	-	-	-	-	3

Notes:

1. The response time will become lower when operated at low temperature.

2. Background color changes slightly depending on ambient temperature.

The phenomenon is reversible.

3. $T_a \leq 40\text{ }^\circ\text{C}$:85%RH MAX.

$T_a > 40\text{ }^\circ\text{C}$:Absolute humidity must be lower than the humidity of 85%RH at 40 $^\circ\text{C}$.

6. Electrical Specifications

6.1 Electrical characteristics ($V_{SS}=0V, T_a=25^\circ C$)

Parameter	Symbol	Condition	Min	Typ	Max	Unit	Note
Power supply	VCC	$T_a=25^\circ C$	3.0	3.3	3.6	V	
Input voltage	'H'	V_{IH}	$T_a=25^\circ C$	0.7VCC	-	VCC	V
	'L'	V_{IL}	$T_a=25^\circ C$	-0.3	-	0.3VCC	V
Current of power supply	ICC	$T_a=25^\circ C$	-	100	-	mA	

6.2 LED backlight specification ($V_{SS}=0V, T_a=25^\circ C$)

Item	Symbol	Condition	Min	Typ	Max	Unit	Note
Supply voltage	Vf	$I_f=240mA$	18.9	21.0	23.1	V	
Uniformity	ΔBp	$I_f=240mA$	75	80	-	%	
Life Time	time	$I_f=240mA$	20K	50K	-	hours	1

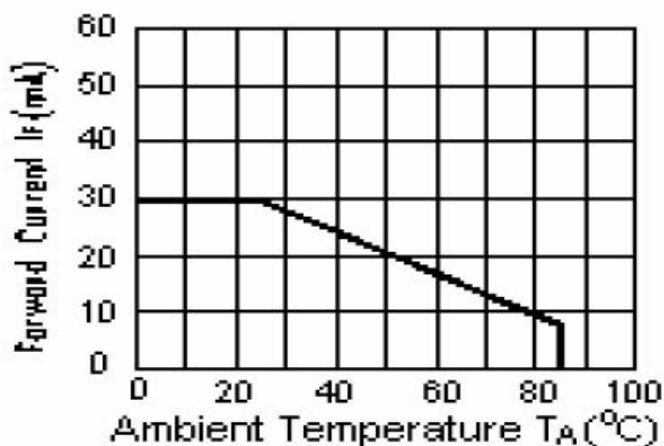

Note 1: Brightness to be decreased to 50% of the initial value at ambient temperature $T_A=25^\circ C$

6.3 Interface signals

6.3.1 CN 1(Interface Signal)

Pin No.	Symbol	I/O	Function	
1-2	VCC	P	Power supply	
3-4	GND	P	Ground.	
5	LINK0-	I	LVDS lane0 input	
6	LINK0+	I		
7	GND	P	Ground.	
8	LINK1-	I	LVDS lane1 input	
9	LINK1+	I		
10	GND	P	Ground.	
11	LINK2-	I	LVDS lane2 input	
12	LINK2+	I		
13	GND	P	Ground.	
14	CLKIN-	I	LVDS CLK input	
15	CLKIN+	I		
16	GND	P	Ground.	
17	LINK3-	I	LVDS lane3 input	
18	LINK3+	I		
19	MODE	I	MODE=1	LVDS 8 BIT
			MODE=0	LVDS 6 BIT
20	SC	I	Scan direction control (Low=Normal, High=Reverse)	

6.3.2 CN 2(Backlight)

Pin No.	Symbol	I/O	Function
1-2	NC	-	No connection
3	LEDC1	P	LED back light(Cathode)
4	LEDA1	P	LED back light(Anode)
5	LEDA2	P	LED back light(Anode)
6	LEDC2	P	LED back light(Cathode)

6.4 AC Characteristics

6.4.1 For the digital circuit: LVDS mode

Parameter	Symbol	Condition	Spec.			Unit
			Min.	Typ.	Max.	
Differential input high Threshold voltage	V _{th}	V _{cm} =1.2V	-	-	+0.1	V
Differential input low threshold voltage	V _{tl}	-	-0.1	-	-	V
Differential input common Mode voltage	V _{CM}	-	1	1.2	1.7- V _{id} /2	V
LVDS input voltage	V _{INLV}	-	0.7	-	1.7	V
Differential input voltage	V _{id}	-	0.1	-	0.6	V
Differential input leakage Current	I _{lvleak}	-	-10	-	+10	μA

Single-ended:
 LVCLKP(R),
 LVCLKN(R),
 LVD[3:0]P(R),
 LVD[3:0]N(R)

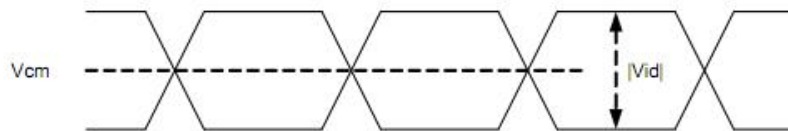

Differential:
 LVCLKP(R)-LVCLKN(R),
 LVD[3:0]P(R)-
 LVD[3:0]N(R)

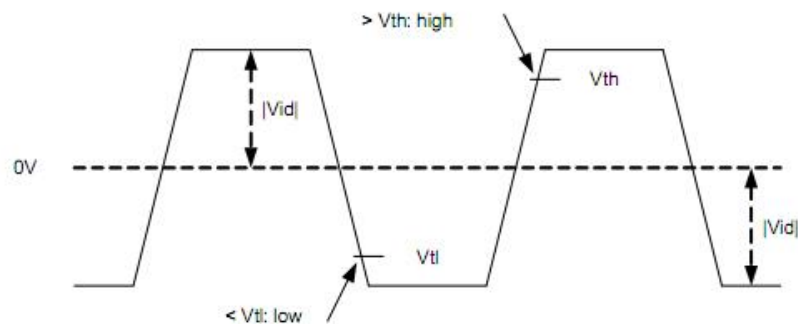

6.4.2 For the analog circuit: Normal mode

Parameter	Symbol	Conditions	Spec.			Unit
			Min.	Typ.	Max.	
Analog positive supply voltage	VSP	VSP is generated by PFM, VSPS[4:0]=14h, with proper settings and components.	6.7	7	7.3	V
Analog negative supply voltage	VSN	VSN is generated by PFM, VSNS[4:0]=14h, with proper settings and components.	-7.3	-7	-6.7	V
Source driver positive supply voltage	VSDP	VSP ≥ 7V, VSDPS[4:0]=14h, loading current=0	6.65	6.8	6.95	V
Source driver negative supply voltage	VSDN	VSN = -7V, VSDNS[4:0]=14h, loading current=0	-6.95	-6.8	-6.65	V
Output for positive gamma reference high voltage	VGMPHO	VSDP ≥ 6.8V, VGMPHS[4:0]=0x1Ah	6.48	6.6	6.72	V
Output for positive gamma reference voltage	VGMPMO	VSDP ≥ 6.8V, VGMPHS[4:0]=0x1Ah, VGMPHS[3:0]=0x00h	3.3	3.4	3.5	V

Output for positive gamma reference low voltage	VGMPLO	VGMPLS[3:0]=0x00h	0.12	0.2	0.28	V
Output for negative gamma reference high voltage	VGMNHO	VSDN \leq -6.8V, VGMNHS[4:0]=0x1Ah	-6.72	-6.6	-6.48	V
Output for negative gamma reference voltage	VGMNMO	VSDN \leq -6.8V, VGMNHS[4:0]=0x1Ah VGMNLS[4:0]=0x00h	-3.5	-3.4	-3.3	V
Output for negative gamma reference low voltage	VGMNLO	VGMNLS[4:0]=0x00h	-0.28	-0.2	-0.12	V
VCOM voltage	VCOM	VCOMS[7:0]=0x80h	-1.53	-1.48	-1.43	V
Source output voltage, positive polarity	V _{SDOP}	-	0.2	-	VSDP-0.2	V
Source output voltage, negative polarity	V _{SDON}	-	VSDN+0.2	-	-0.2	V
Positive power supply	VGH	VGH is generated by charge pump, VGHS[3:0]=0x05h, loading current=0	14.6	15.6	16.6	V
Negative power supply	VGL	VGL is generated by charge pump, VGLS[2:0]=0x02h, loading current=0	-11	-10	-9	V

Parameter	Symbol	Conditions	Spec.			Unit
			Min.	Typ.	Max.	
Source output voltage deviation	V _{OD}	V _{SDOP} =0.5V to VSDP-0.5V, V _{SDON} =VSDN+0.5V to -0.5V	-	-	10	mV
		V _{SDOP} =0.2V to 0.5V or V _{SDOP} =VSDP-0.5V to VSDP-0.2V, V _{SDON} =VSDN+0.2V to VSDN+0.5V or V _{SDON} =-0.5V to -0.2V	-	-	15	mV
Standby current (VCC1 + VCC2)	I _{STBVCC}	"STBYB=0" and all inputs are default.	-	-	100	μ A
Standby current (VSN or VSP)	I _{STB}	"STBYB=0", VSP or VSN external input	-	-	100	μ A

6.4.3 LVDS mode AC electrical characteristics

Parameter	Symbol	Spec.			Unit
		Min.	Typ.	Max.	
Clock frequency	F_{LVDCYC}	20	-	85	MHz
Clock period	T_{LVDCYC}	11.76	-	-	ns
1 data bit time	UI	-	1/7	-	T_{LVDCYC}
Clock high time	T_{LVCH}	2.8	4	4.2	UI
Clock low time	T_{LVCL}	2.8	3	4.2	UI
Position 1	T_{POS1}	-0.2	0	0.2	UI
Position 0	T_{POS0}	0.8	1	1.2	UI
Position 6	T_{POS6}	1.8	2	2.2	UI
Position 5	T_{POS5}	2.8	3	3.2	UI
Position 4	T_{POS4}	3.8	4	4.2	UI
Position 3	T_{POS3}	4.8	5	5.2	UI
Position 2	T_{POS2}	5.8	6	6.2	UI
Input eye width	T_{EYEW}	0.6	-	-	UI
Input eye border	T_{EX}	-	-	0.2	UI
LVDS wake up time	T_{ENLVDS}	-	-	150	us

LVDS with SSC

Parameter	Symbol	Condition	Spec.			Unit
			Min.	Typ.	Max	
Modulation Frequency	SSC_{MF}	LVDS clock frequency center at 80MHz	-	-	200	KHz
		LVDS clock frequency center at 60MHz	-	-	150	KHz
		LVDS clock frequency center at 40MHz	-	-	100	KHz
		LVDS clock frequency center at 20MHz	-	-	50	KHz
Modulation Rate	SSC_{MR}	LVDS clock frequency + SSC_{MR} in the range of 20MHz~85MHz	-	-	±5	%

6.4.4 TTL mode AC electrical characteristics

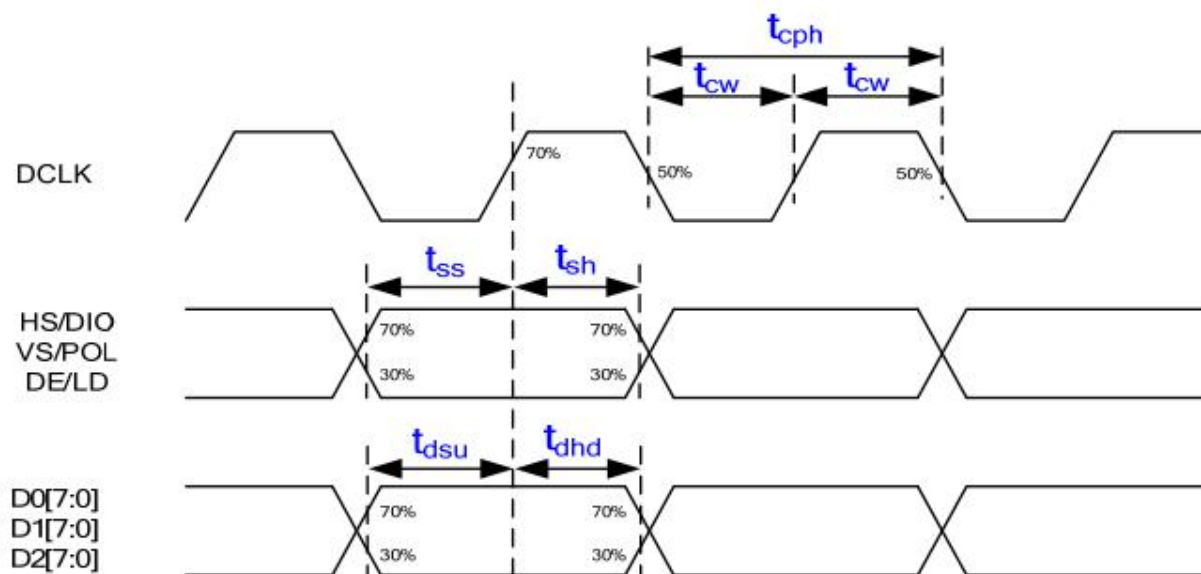

Parameter	Symbol	Spec.			Unit
		Min.	Typ.	Max.	
DCLK period	T_{cph}	16.67	-	-	ns
DCLK duty ratio	T_{CW}	40	50	60	%
Data setup time	T_{dsu}	5	-	-	ns
Data hold time	T_{dhd}	5	-	-	ns
VS/POL setup time	T_{ss}	5	-	-	ns
VS/POL hold time	T_{sh}	5	-	-	ns
HS/DIO setup time	T_{ss}	5	-	-	ns
HS/DIO hold time	T_{sh}	5	-	-	ns
DE/LD setup time	T_{ss}	5	-	-	ns
DE/LD hold time	T_{sh}	5	-	-	ns

6.5 Reset timing

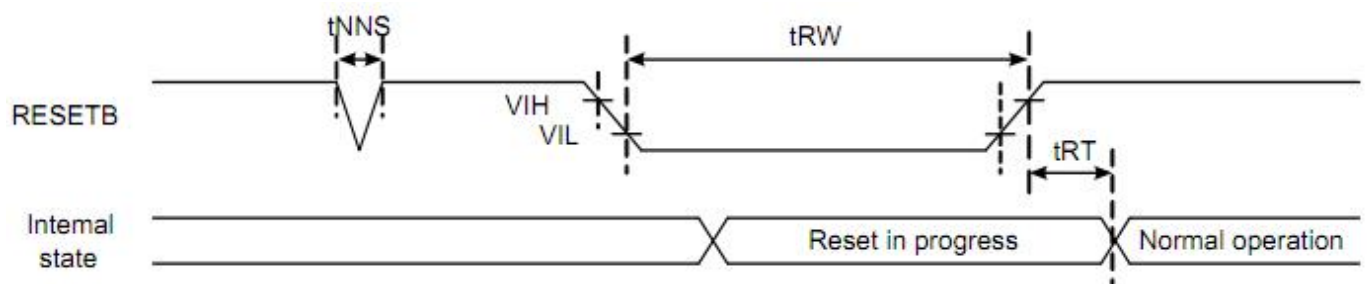

Signal	Parameter	Symbol	Spec.			Unit
			Min.	Typ.	Max.	
RESETB	Reset pulse width	tRW	10	-	-	μ s
	Reset complete time	tRT	-	-	5	μ s
	Negative spike noise width	tNNS	-	-	100	ns

6.6 Input timing table

ITEM		SYMBOL	MIN	TYP	MAX	UNIT	
DCLK	Frequency	f_{CLK}	25	30.4	45	MHz	
	Period	t_{CLK}	22.2	32.9	40	ns	
DENA	Horizontal	Active Time	t_{HA}	800	800	800	tCLK
		Blanking Time	t_{HB}	20	160	--	tCLK
		Frequency	f_H	26.4	31.7	45	kHz
		Period	t_H	22.2	31.6	37.9	μ s
	Vertical	Active Time	t_{VA}	480	480	480	tH
		Blanking Time	t_{VB}	3	48	--	tH
		Frequency	f_V	55	60	75	Hz
		Period	t_V	13.3	16.7	18.2	ms

6.7 LVDS interface

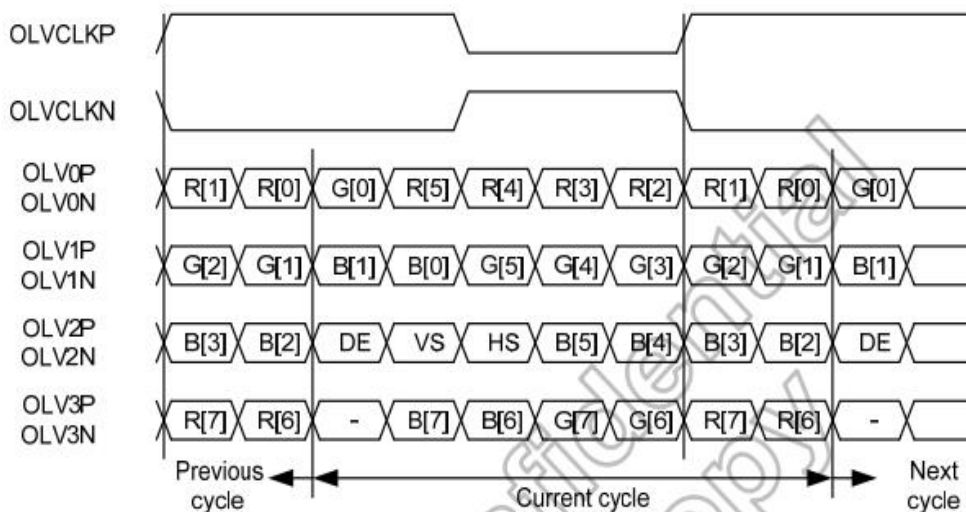

8bit mode

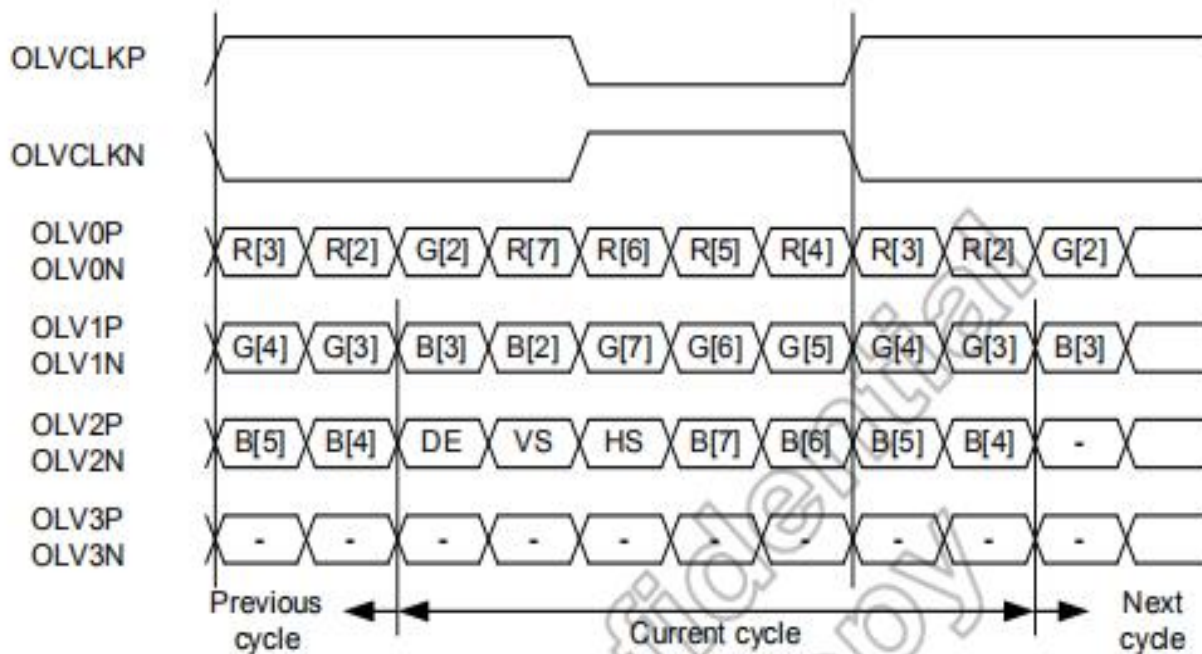

6bit mode

6.8 Block Diagram

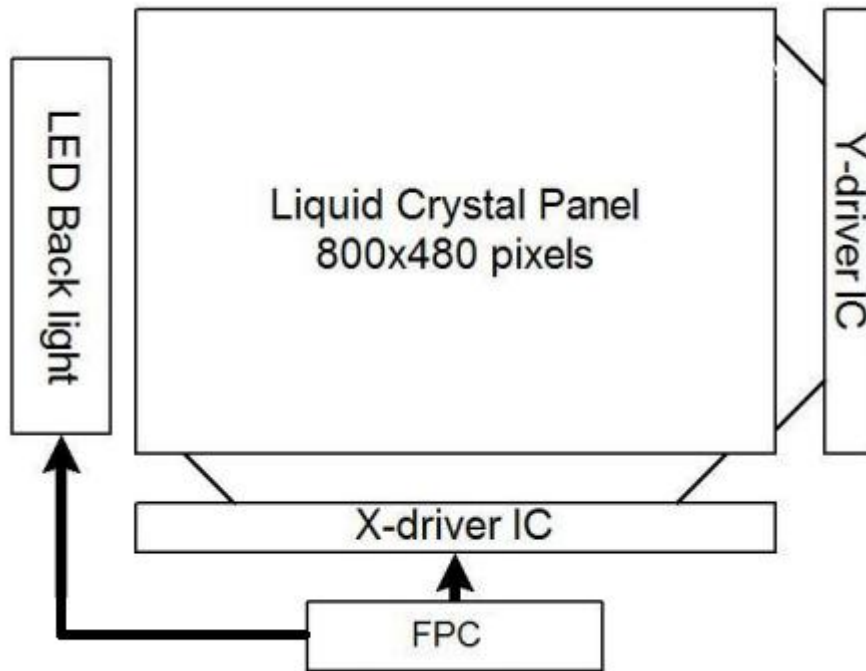

Pixel Format

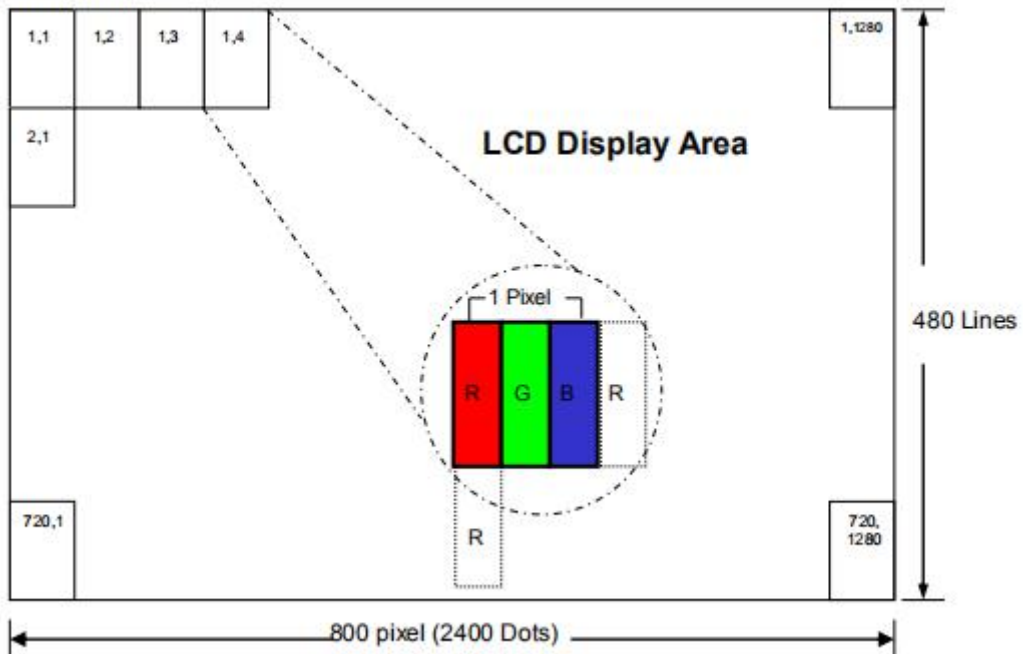

Relationship Between Displayed Color and Input

	Display	MSB								LSB								Gray scale Level								
		R7	R6	R5	R4	R3	R2	R1	R0	G7	G6	G5	G4	G3	G2	G1	G0		B7	B6	B5	B4	B3	B2	B1	B0
Basic color	Black	L	L	L	L	L	L	L	L	L	L	L	L	L	L	L	L	L	L	L	L	L	L	L	L	-
	Blue	L	L	L	L	L	L	L	L	L	L	L	L	L	L	L	L	H	H	H	H	H	H	H	H	-
	Green	L	L	L	L	L	L	L	L	H	H	H	H	H	H	H	H	L	L	L	L	L	L	L	L	-
	Light Blue	L	L	L	L	L	L	L	L	H	H	H	H	H	H	H	H	H	H	H	H	H	H	H	H	-
	Red	H	H	H	H	H	H	H	H	L	L	L	L	L	L	L	L	L	L	L	L	L	L	L	L	-
	Purple	H	H	H	H	H	H	H	H	L	L	L	L	L	L	L	L	H	H	H	H	H	H	H	H	-
	Yellow	H	H	H	H	H	H	H	H	H	H	H	H	H	H	H	H	L	L	L	L	L	L	L	L	-
	White	H	H	H	H	H	H	H	H	H	H	H	H	H	H	H	H	H	H	H	H	H	H	H	H	-
Gray scale of Red	Black	L	L	L	L	L	L	L	L	L	L	L	L	L	L	L	L	L	L	L	L	L	L	L	L	L0
	Dark ↑	L	L	L	L	L	L	L	H	L	L	L	L	L	L	L	L	L	L	L	L	L	L	L	L	L1
		L	L	L	L	L	L	H	L	L	L	L	L	L	L	L	L	L	L	L	L	L	L	L	L	L2
		:	:	:	L3...L251																					
	↓ Light	H	H	H	H	H	H	L	L	L	L	L	L	L	L	L	L	L	L	L	L	L	L	L	L	L252
		H	H	H	H	H	H	L	H	L	L	L	L	L	L	L	L	L	L	L	L	L	L	L	L	L253
		H	H	H	H	H	H	H	L	L	L	L	L	L	L	L	L	L	L	L	L	L	L	L	L	L254
	Red	H	H	H	H	H	H	H	L	L	L	L	L	L	L	L	L	L	L	L	L	L	L	L	Red L255	
Gray scale of Green	Black	L	L	L	L	L	L	L	L	L	L	L	L	L	L	L	L	L	L	L	L	L	L	L	L	L0
	Dark ↑	L	L	L	L	L	L	L	L	L	L	L	L	L	L	L	H	L	L	L	L	L	L	L	L	L1
		L	L	L	L	L	L	L	L	L	L	L	L	L	L	L	L	L	L	L	L	L	L	L	L	L2
		:	:	:	L3...L251																					
	↓ Light	L	L	L	L	L	L	L	L	H	H	H	H	H	L	L	L	L	L	L	L	L	L	L	L252	
		L	L	L	L	L	L	L	L	H	H	H	H	H	L	H	L	L	L	L	L	L	L	L	L253	
		L	L	L	L	L	L	L	L	H	H	H	H	H	H	L	L	L	L	L	L	L	L	L	L254	
	Green	L	L	L	L	L	L	L	H	H	H	H	H	H	H	L	L	L	L	L	L	L	L	Green L255		
Gray scale of Blue	Black	L	L	L	L	L	L	L	L	L	L	L	L	L	L	L	L	L	L	L	L	L	L	L	L	L0
	Dark ↑	L	L	L	L	L	L	L	L	L	L	L	L	L	L	L	L	L	L	L	L	L	L	L	H	L1
		L	L	L	L	L	L	L	L	L	L	L	L	L	L	L	L	L	L	L	L	L	H	L	L	L2
		:	:	:	L3...L251																					
	↓ Light	L	L	L	L	L	L	L	L	L	L	L	L	L	L	L	L	H	H	H	H	H	L	L	L	L252
		L	L	L	L	L	L	L	L	L	L	L	L	L	L	L	L	H	H	H	H	H	L	H	L	L253
		L	L	L	L	L	L	L	L	L	L	L	L	L	L	L	L	H	H	H	H	H	H	L	L	L254
	Blue	L	L	L	L	L	L	L	L	L	L	L	L	L	L	L	H	H	H	H	H	H	H	H	Blue L255	
Gray scale of White & Black	Black	L	L	L	L	L	L	L	L	L	L	L	L	L	L	L	L	L	L	L	L	L	L	L	L	L0
	Dark ↑	L	L	L	L	L	L	H	L	L	L	L	L	L	H	L	L	L	L	L	L	H	L	L1		
		L	L	L	L	L	L	H	L	L	L	L	L	H	L	L	L	L	L	H	L	L	L2			
		:	:	:	L3...L251																					
	↓ Light	H	H	H	H	H	L	L	H	H	H	H	H	L	L	H	H	H	H	H	L	L	L	L252		
		H	H	H	H	H	L	H	H	H	H	H	L	H	H	H	H	H	L	H	L	L	L253			
		H	H	H	H	H	H	L	H	H	H	H	H	L	H	H	H	H	H	L	L	L	L254			
	White	H	H	H	H	H	H	H	H	H	H	H	H	H	H	H	H	H	H	H	H	H	White L255			

7. Optical Characteristics

Item	Symbol	Condition	Min.	Typ.	Max.	Unit	Note	
Luminance	Bp	$\theta=0^\circ$	-	1500	-	Cd/m ²	1	
Uniformity	Δ Bp	$\Phi=0^\circ$	75	80	-	%	1,2	
Viewing Angle	3:00	$Cr \geq 10$	-	80	-	Deg	3	
	6:00		-	80	-			
	9:00		-	80	-			
	12:00		-	80	-			
Contrast Ratio	Cr	$\theta=0^\circ$	500	800	-	-	4	
Response Time	T_r+T_f	$\Phi=0^\circ$	-	25	35	ms	5	
Color of CIE Coordinate	W	x	$\theta=0^\circ$ $\Phi=0^\circ$	Typ -0.05	0.306	Typ +0.05	-	1,6
		y			0.331		-	
	R	x			0.648		-	
		y			0.317		-	
	G	x			0.286		-	
		y			0.606		-	
	B	x			0.138		-	
		y			0.098		-	
NTSC Ratio	S	-	71.7	-	%			

Note: The parameter is slightly changed by temperature, driving voltage and materiel

Note 1: The data are measured after LEDs are turned on for 5 minutes. LCM displays full white. The brightness is the average value of 9 measured spots. Measurement equipment BM-7

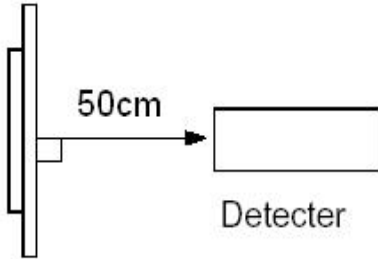

(Φ5mm)

Measuring condition:

- Measuring surroundings: Dark room.
- Measuring temperature: $T_a=25\text{ }^\circ\text{C}$.
- Adjust operating voltage to get optimum contrast at the center of the display.

Measured value at the center point of LCD panel after more than 5 minutes while backlight turning on.

Note 2: The luminance uniformity is calculated by using following formula.

$$\Delta B_p = B_p (\text{Min.}) / B_p (\text{Max.}) \times 100 (\%)$$

$B_p (\text{Max.})$ = Maximum brightness in 9 measured spots

$B_p (\text{Min.})$ = Minimum brightness in 9 measured spots.

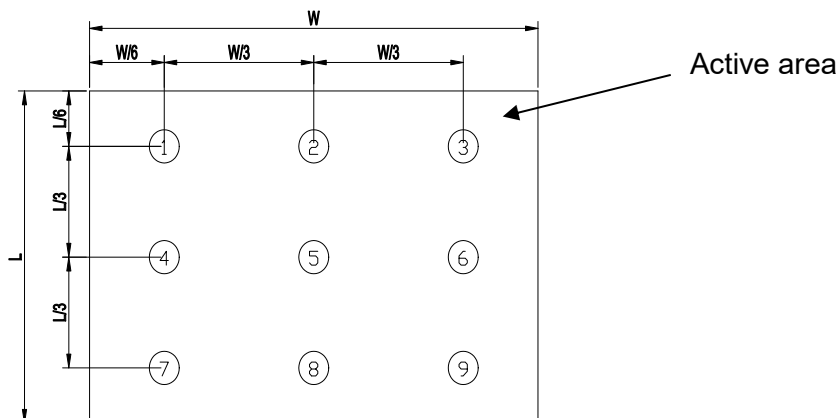

Note 3: The definition of viewing angle:
 Refer to the graph below marked by θ and Φ

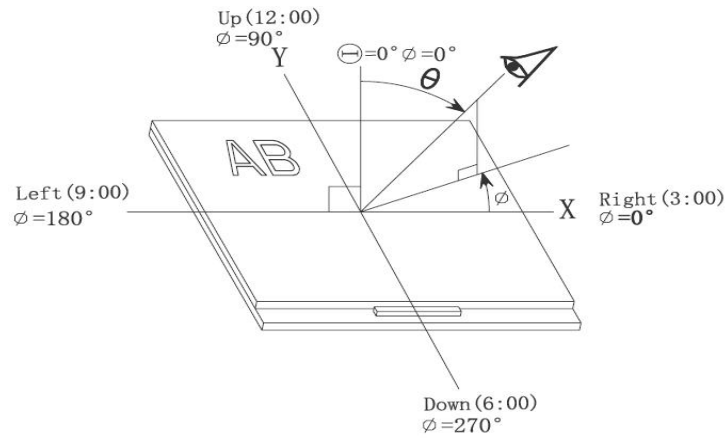

Note 4: Definition of contrast ratio.(Test LCD using DMS501)

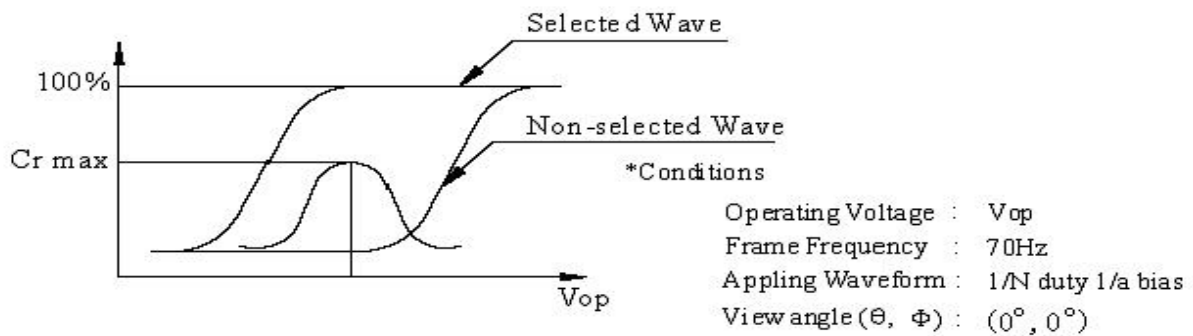

$$\text{Contrast ratio}(Cr) = \frac{\text{Brightness of selected dots}}{\text{Brightness of non-selected dots}}$$

Note 5: Definition of Response time. (Test LCD using DMS501):

The output signals of photo detector are measured when the input signals are changed from “black” to “white”(falling time) and from “white” to “black”(rising time), respectively. The response time is defined as the time interval between the 10% and 90% of amplitudes. Refer to figure as below.

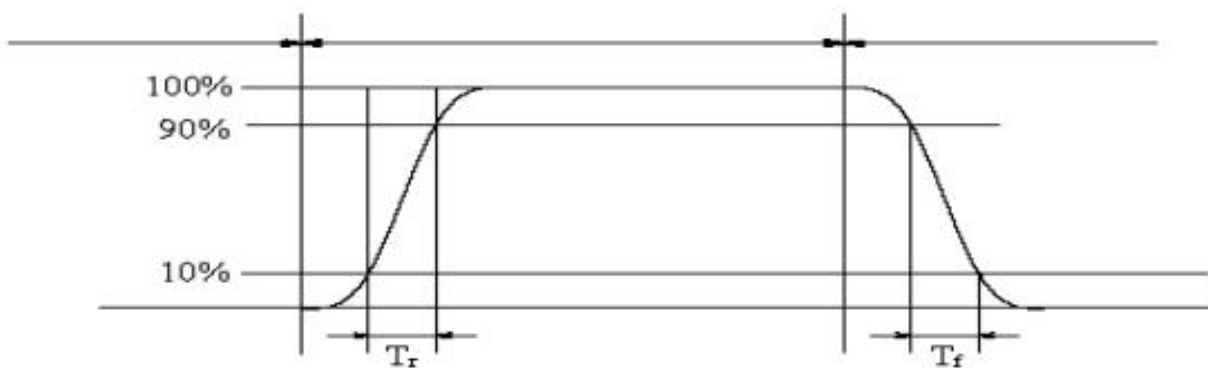

The definition of response time

Note 6: Definition of Color of CIE Coordinate and NTSC Ratio.

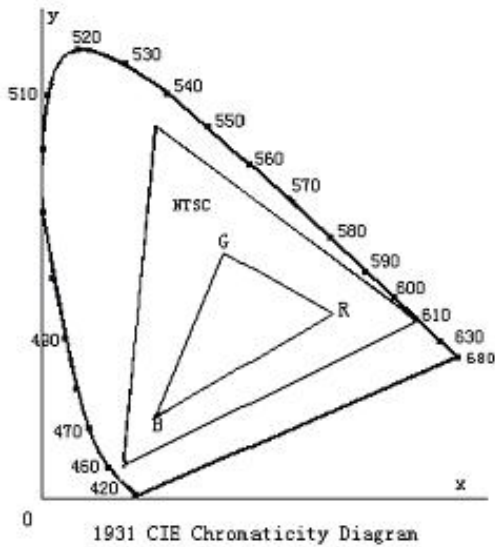

Color gamut:

$$S = \frac{\text{area of RGB triangle}}{\text{area of NTSC triangle}} \times 100\%$$

Note 7: Definition of cross talk.

Cross talk ratio(%) = $\frac{|\text{pattern A Brightness} - \text{pattern B Brightness}|}{\text{pattern A Brightness}} \times 100$

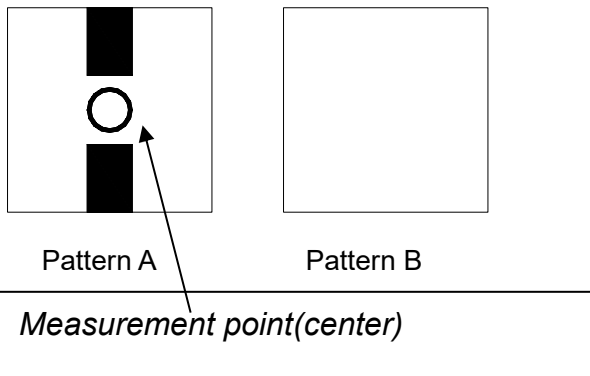

Electric volume value = $3F \pm 3Hex$

8. Reliability Test Items and Criteria

Test Item	Test condition	Remark
High Temperature Storage	Ta = 80°C 96hrs	Note1,Note3, 4
Low Temperature Storage	Ta = -30°C 96hrs	Note1,Note3, 4
High Temperature Operation	Ta = 70°C 96hrs	Note2,Note3, 4
Low Temperature Operation	Ta = -30°C 96hrs	Note1,Note3, 4
Operation at High Temperature/Humidity	+60°C, 90%RH 96hrs	Note3, 4
Thermal Shock	-30°C/30 min ~ +80°C/30 min for a total 10 cycles, Start with cold temperature and end with high temperature.	Note3, 4
Vibration Test	Frequency range:10~55Hz Stroke:1.5mm Sweep:10Hz~55Hz~10Hz 2 hours for each direction of X. Y. Z. (6 hours for total)	
Mechanical Shock	100G 6ms,±X, ±Y, ±Z 3 times for each direction	
Package Vibration Test	Random Vibration : 0.015G*G/Hz from 5-200HZ, -6dB/Octave from 200-500HZ 2 hours for each direction of X. Y. Z. (6 hours for total)	
Package Drop Test	Height:60cm 1 corner, 3 edges, 6 surfaces	
Electro Static Discharge	±2KV, Human Body Mode, 100pF/1500Ω	

Note 1: Ta is the ambient temperature of samples.

Note 2: Ts is the temperature of panel's surface.

Note 3: In the standard condition, there shall be no practical problem that may affect the display function. After the reliability test, the product only guarantees operation, but don't guarantee all of the cosmetic specification.

Note 4: Before cosmetic and function test, the product must have enough recovery time, at least 2 hours at room temperature

9. Precautions for Use of LCD Modules

9.1 Handling Precautions

9.1.1 *The display panel is made of glass. Do not subject it to a mechanical shock by dropping it from a high place, etc.*

9.1.2 *If the display panel is damaged and the liquid crystal substance inside it leaks out, be sure not to get any in your mouth, if the substance comes into contact with your skin or clothes, promptly wash it off using soap and water.*

9.1.3 *Do not apply excessive force to the display surface or the adjoining areas since this may cause the color tone to vary.*

9.1.4 *The polarizer covering the display surface of the LCD module is soft and easily scratched. Handle this polarizer carefully.*

9.1.5 *If the display surface is contaminated, breathe on the surface and gently wipe it with a soft dry cloth. If still not completely clear, moisten cloth with one of the following solvents:*

— Isopropyl alcohol — Ethyl alcohol

Solvents other than those mentioned above may damage the polarizer. Especially, do not use the following:

— Water — Ketone — Aromatic solvents

9.1.6 *Do not attempt to disassemble the LCD Module.*

9.1.7 *If the logic circuit power is off, do not apply the input signals.*

9.1.8 *To prevent destruction of the elements by static electricity, be careful to maintain an optimum work environment.*

a. Be sure to ground the body when handling the LCD Modules.

b. Tools required for assembly, such as soldering irons, must be properly ground.

c. To reduce the amount of static electricity generated, do not conduct assembly and other work under dry conditions.

d. The LCD Module is coated with a film to protect the display surface. Be care when peeling off this protective film since static electricity may be generated.

9.2 Storage precautions

9.2.1 *When storing the LCD modules, avoid exposure to direct sunlight or to the light of fluorescent lamps.*

9.2.2 *The LCD modules should be stored under the storage temperature range. If the LCD modules will be stored for a long time, the recommend condition is:*

Temperature : 0 °C ~ 40 °C

Relatively humidity: ≤ 80%

9.2.3 *The LCD modules should be stored in the room without acid, alkali and harmful gas.*

9.3 *The LCD modules should be no falling and violent shocking during transportation, and also should avoid excessive press, water, damp and sunshine.*

END

Our company network supports you worldwide with offices in Germany, Austria, Switzerland, the UK and the USA. For more information please contact:

Headquarters

Germany



FORTEC Elektronik AG

Augsburger Str. 2b
82110 Germering

Phone: +49 89 894450-0
E-Mail: info@forteca.de
Internet: www.forteca.de

Fortec Group Members

Austria



Distec GmbH Office Vienna

Nuschinggasse 12
1230 Wien

Phone: +43 1 8673492-0
E-Mail: info@distec.de
Internet: www.distec.de

Germany



Distec GmbH

Augsburger Str. 2b
82110 Germering

Phone: +49 89 894363-0
E-Mail: info@distec.de
Internet: www.distec.de

Switzerland



ALTRAC AG

Bahnhofstraße 3
5436 Würenlos

Phone: +41 44 7446111
E-Mail: info@altrac.ch
Internet: www.altrac.ch

United Kingdom



Display Technology Ltd.

Osprey House, 1 Osprey Court
Hichingbrooke Business Park
Huntingdon, Cambridgeshire, PE29 6FN

Phone: +44 1480 411600
E-Mail: info@displaytechnology.co.uk
Internet: www.displaytechnology.co.uk

USA



Apollo Display Technologies, Corp.

87 Raynor Avenue,
Unit 1 Ronkonkoma,
NY 11779

Phone: +1 631 5804360
E-Mail: info@apolloDisplays.com
Internet: www.apolloDisplays.com