Datasheet

ORTUSTECH

COM32H3P25ULC

The information contained in this document has been carefully researched and is, to the best of our knowledge, accurate. However, we assume no liability for any product failures or damages, immediate or consequential, resulting from the use of the information provided herein. Our products are not intended for use in systems in which failures of product could result in personal injury. All trademarks mentioned herein are property of their respective owners. All specifications are subject to change without notice.

Specifications for

Blanview TFT-LCD Monitor (3.2" WVGA 480 x RGB x 800 Portrait)

Version 1.0

(Please be sure to check the specifications latest version.)

MODEL COM32H3P25ULC

Customer's Approval

Signature:

Name:

Section:

Title:

Date:

ORTUSTECH

ORTUS TECHNOLOGY CO., LTD.

Approved by

Y. Nakajima

Checked by

R. Kurokuma

Prepared by

M. Shibamoto

Contents

1. Application	3
2. Outline Specifications		
2.1 Features of the Product	4
2.2 Display Method	4
3. Dimensions and Shape		
3.1 Dimensions	6
3.2 Outward Form	7
3.3 Serial No. print (S-print)	8
4. Pin Assignment	9
5. Absolute Maximum Rating	10
6. Recommended Operating Conditions	10
7. Characteristics		
7.1 DC Characteristics		
7.1.1 Display Module	11
7.1.2 MIPI DSI Interface	11
7.1.3 Backlight	12
7.2 AC Characteristics		
7.2.1 HS-RX Specifications	13
7.2.2 LP-TX Specifications	13
7.2.3 RX/TX Specifications	14
7.2.4 Reset input timing	16
7.3 Input Timing Characteristics	16
7.4 Input Signal Timing Chart	17
8. About MIPI Interface		
8.1 Version	18
8.2 DSI protocol	18
8.3 Packet data types	19
8.4 Packet Footer on the long packet	19
9. Sequence		
9.1 Power-ON Sequence	20
9.2 Power-OFF Sequence	23
9.3 Sleep Sequence	23
9.4 Sleep Release Sequence	23
9.5 Power ON/OFF timing	24
9.6 Refresh Sequence	25
10. LED Circuit	27
11. Characteristics		
11.1 Optical Characteristics	28
11.2 Temperature Characteristics	29
12. Criteria of Judgment		
12.1 Defective Display and Screen Quality	30
12.2 Screen and Other Appearance	31
13. Reliability Test	32
14. Packing Specifications	34
15. Handling Instruction		
15.1 Cautions for Handling LCD panels	35
15.2 Precautions for Handling	36
15.3 Precautions for Operation	36
15.4 Storage Condition for Shipping Cartons	37
15.5 Precautions for Peeling off the Protective film	38
15.6 Warranty	38
APPENDIX	39

1. Application

This Specification is applicable to 80.5mm (3.2 inch) Blanview TFT-LCD monitor for non-military use.

- ⊙ ORTUS TECHNOLOGY makes no warranty or assume no liability that use of this Product and/or any information including drawings in this Specification by Purchaser is not infringing any patent or other intellectual property rights owned by third parties, and ORTUS TECHNOLOGY shall not grant to Purchaser any right to use any patent or other intellectual property rights owned by third parties. Since this Specification contains ORTUS TECHNOLOGY's confidential information and copy right, Purchaser shall use them with high degree of care to prevent any unauthorized use, disclosure, duplication, publication or dissemination of ORTUS TECHNOLOGY's confidential information and copy right.
- ⊙ If Purchaser intends to use this Products for an application which requires higher level of reliability and/or safety in functionality and/or accuracy such as transport equipment (aircraft, train, automobile, etc.), disaster-prevention/security equipment or various safety equipment, Purchaser shall consult ORTUS TECHNOLOGY on such use in advance.
- ⊙ This Product shall not be used for application which requires extremely higher level of reliability and/or safety such as aerospace equipment, telecommunication equipment for trunk lines, control equipment for nuclear facilities or life-support medical equipment.
- ⊙ ORTUS TECHNOLOGY assumes no liability for any damage resulting from misuse, abuse, and/or miss-operation of the Product deviating from the operating conditions and precautions described in the Specification.
- ⊙ If any issue arises as to information provided in this Specification or any other information, ORTUS TECHNOLOGY and Purchaser shall discuss them in good faith and seek solution.
- ⊙ ORTUS TECHNOLOGY assumes no liability for defects such as electrostatic discharge failure occurred during peeling off the protective film or Purchaser's assembly process.
- ⊙ This Product is compatible for RoHS directive.

Object substance	Maximum content [ppm]
Cadmium and its compound	100
Hexavalent Chromium Compound	1000
Lead & Lead compound	1000
Mercury & Mercury compound	1000
Polybrominated biphenyl series (PBB series)	1000
Polybrominated biphenyl ether series (PBDE series)	1000

<Features of Blanview>

- Backlight power consumption required to assure visibility. (equivalent to 3.5"QVGA)

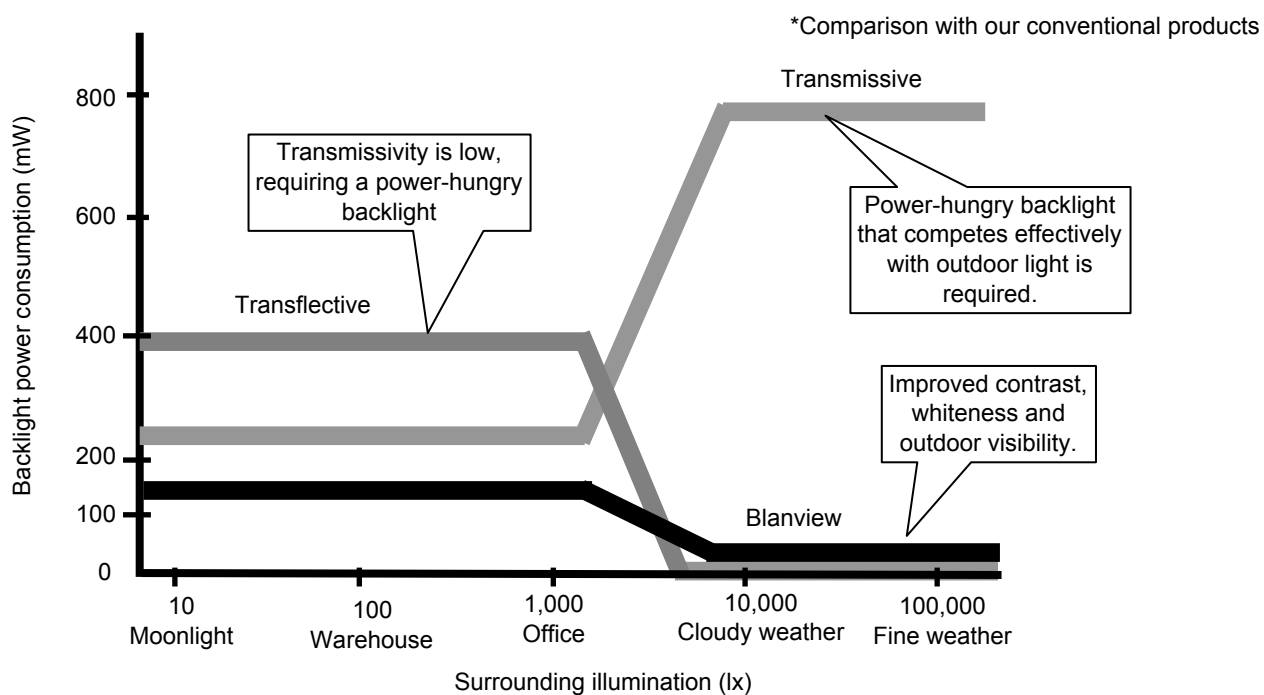

- Contrast characteristics under 100,000lx. (same condition as direct sunlight.)

With better contrast (higher contrast ratio), Blanview TFT-LCD has the best outdoor readability in three different types of TFT-LCD.

Below chart shows contrast value against panel surface brightness. (Horizontal: Panel surface brightness/ Vertical: Contrast value) LCD panel has enough outdoor readability above our Standard line. (ORTUS TECHNOLOGY criteria)

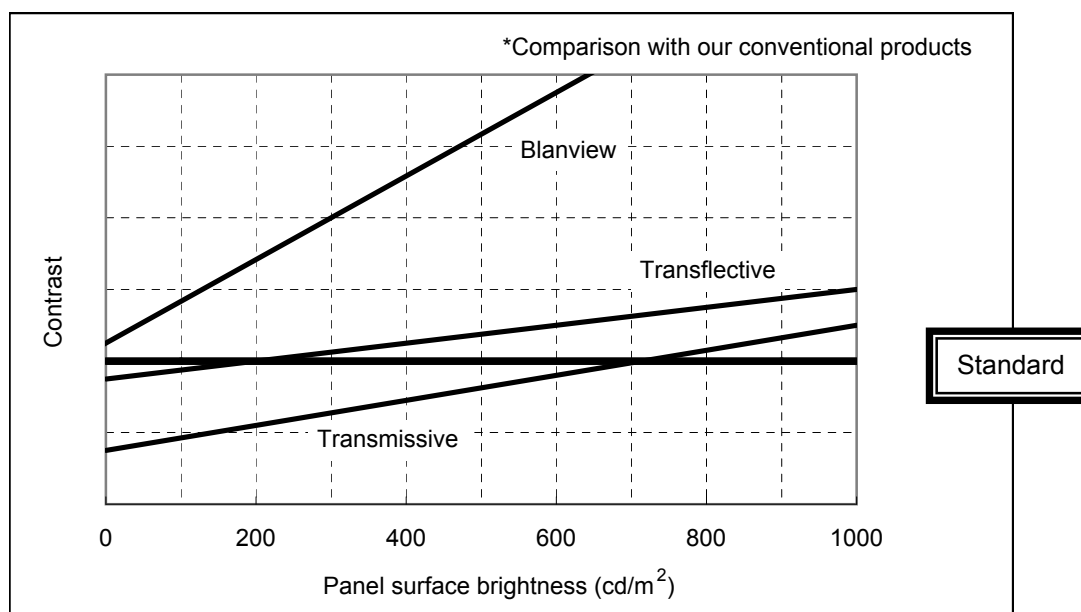

3. Dimensions and Shape

3.1 Dimensions

Items	Specifications	Unit	Remarks
Outline dimensions	46.66[H] × 78.55[V] × 1.75[D]	mm	Exclude FPC cable and parts on FPC
Active area	41.40[H] × 69.00[V]	mm	
Number of dots	1440[H] × 800[V]	dot	
Dot pitch	28.75[H] × 86.25[V]	um	
Surface hardness of the polarizer	3	H	Load: 2.0 N
Weight	14.7	g	Include FPC cable

3.2 Outward Form

EC No.	REV. No.	REVISE	DATE (Y:M:D)	APPROVED	CHECKED	PREPARED
--------	----------	--------	--------------	----------	---------	----------

(7/42)
16TLM039
Issue: Jun.21,2017

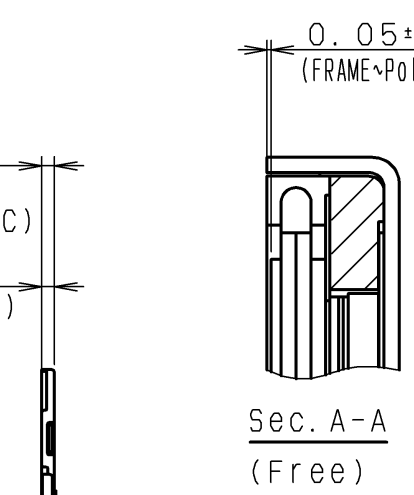
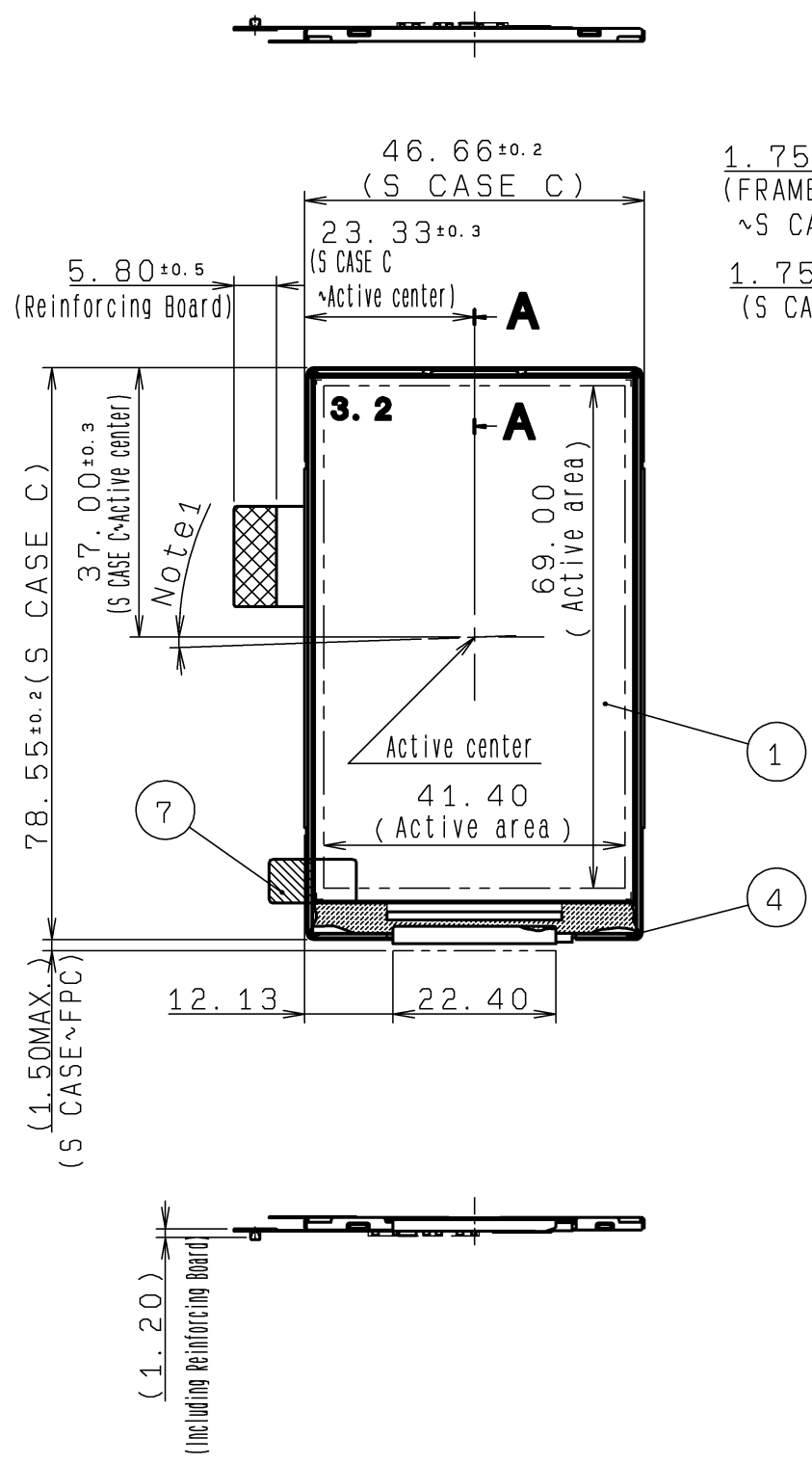

- 1.75±0.15 (FRAME ~S CASE C)
- 1.75±0.1 (S CASE C)
- 0.90MAX. (Surface of LCD FPC ~top of electronic parts)
- 1.50MAX. (S CASE C ~top of electronic parts)
- 0.60MAX. (S CASE C ~LED FPC)
- (2.0MAX.) (Note. 4) (Height of FPC floating)

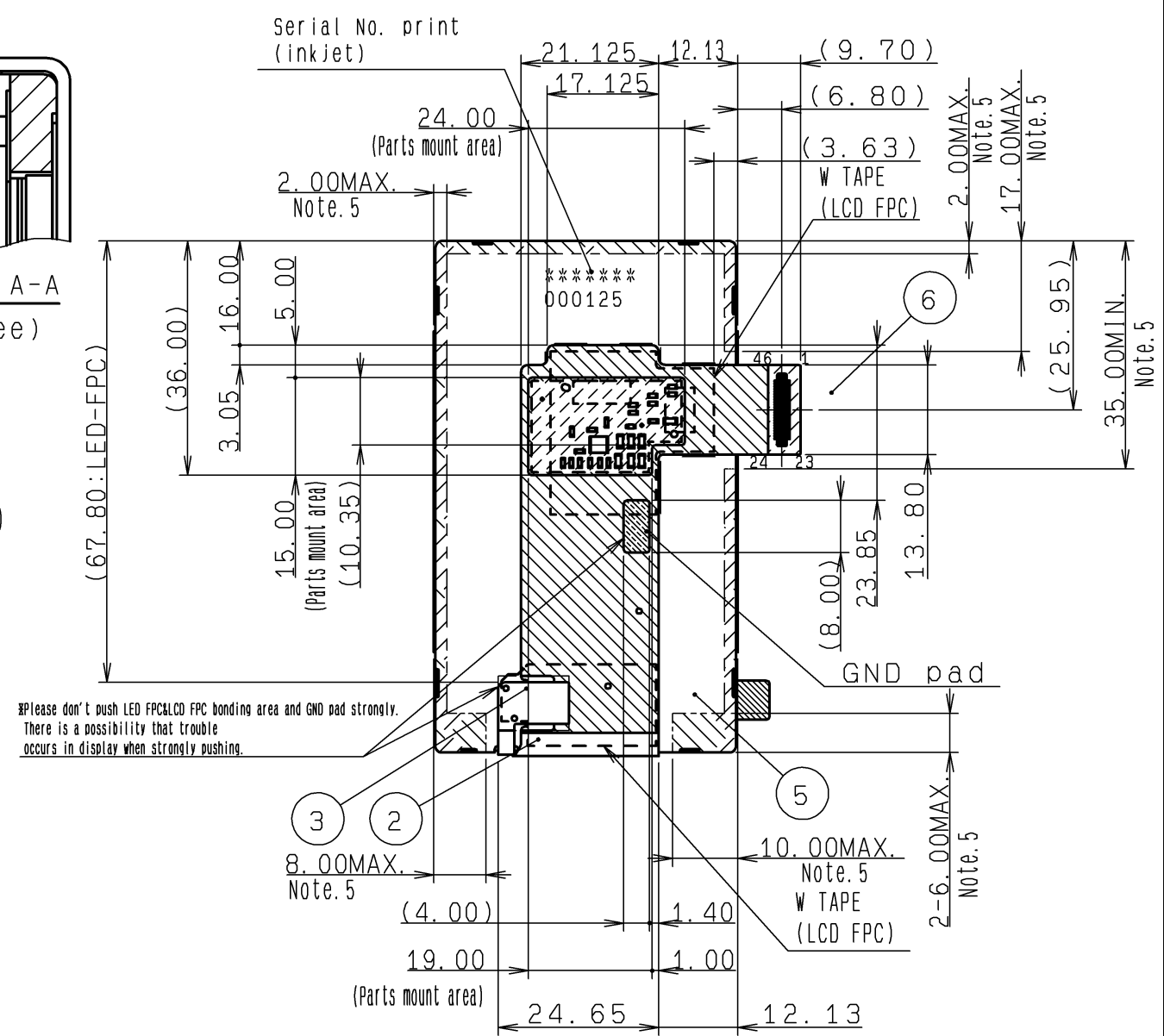

※Please don't push LED FPC&LCD FPC bonding area and GND pad strongly. There is a possibility that trouble occurs in display when strongly pushing.

- Note 1. Angular deviation of LCD cell from the TFT-LCD monitor's reference axis shall be less than [±40°].
- Note 2. Protective film is affixed on front surface of the screen. Location tolerance of the protective film shall be ±1.5 mm to the polarizing film.
- Note 3. In order to realize thin module structure, double-sided adhesive tapes are used to fix LCD panels. As these tapes do not guarantee to permanently fix the panels. LCD panel may rize from the module when shipped from factory. So please make sure to design the system to hold the edges of LCD panel by the soft material such as sponge when LCD module is assembled into the cabinet.
- Note 4. In order to realize thin module structure, double-sided adhesive tapes are used to fix FPC at S CASE C. As these tapes do not guarantee to permanently fix the FPC near the bending area, FPC may rize from the module when shipped from factory.
- Note 5. In case TFT-LCD monitor is fixed to the case of your product, it's recommended that monitor is fixed in to [hatched] area.

R TAPE	7			
Connector	6	AXT446124/Panasonic		User side:AXT346124/Panasonic
S CASE C	5		SUS	
FRAME	4		PC	
LED FPC	3			
LCD FPC	2			
TFT-LCD PANEL	1		ガラス厚さ=0.2t+0.2t	
PART NAME	ITEM	PART CODE	MODEL NUMBER	REMARK
APPROVED 敷地	GENERAL TOLERANCE ±0.5	SCALE 1/1	UNIT mm	ORTUSTECH ORTUS TECHNOLOGY CO., LTD. DO NOT DUPLICATE, CONFIDENTIAL AND PROPRIETARY
CHECKED 木下	ISSUE (Y:M:D) 16:10:31	MODEL COM32H3P25U**		
CHECKED	NAME			DRAWING No. REV. SHEET DIV.
DESIGN 萩野				
DRAW 萩野				
OUTLINE-D3P25				RJD528428D301

3.3 Serial № print (S-print)

1) Display Items

S-print indicates the least significant digit of manufacture year (1digit), manufacture month with below alphabet (1letter), model code (5characters), serial number (6digits).

* Contents of Display

*	*	*****	*****
-	-	-----	-----
a	b	c	d

Contents of display				
a	The least significant digit of manufacture year			
b	Manufacture month	Jan-A Feb-B Mar-C Apr-D	May-E Jun-F Jul-G Aug-H	Sep-I Oct-J Nov-K Dec-L
c	Model code	32XC (Made in Japan) 32YC (Made in Malaysia)		
d	Serial number			

* Example of indication of Serial № print (S-print)

•Made in Japan

7J32XC000125

means "manufactured in October 2017, 3.2" X type, C specifications, serial number 000125"

•Made in Malaysia

7J32YC000125

means "manufactured in October 2017, 3.2" Y type, C specifications, serial number 000125"

2) Location of Serial № print (S-print)

Refer to 3.2 "Outward Form".

3)Others

Please note that it is likely to disappear with an organic solvent about the Serial print.

4. Pin Assignment

№	Symbol	Details	Remark	IO
1	GND			P
2	GND			P
3	GND			P
4	GND			P
5	GND			P
6	GND			P
7	GND			P
8	PVSS	Test Pin	Please connect to GND.	P
9	GND			P
10	DSI_D1N	MIPI-DSI Data differential signal input pin(Data lane 1)		I
11	DSI_D1P	MIPI-DSI Data differential signal input pin(Data lane 1)		I
12	GND			P
13	DSI_CP	MIPI-DSI Clock differential signal input pin		I
14	DSI_CN	MIPI-DSI Clock differential signal input pin		I
15	GND			P
16	DSI_D0N	MIPI-DSI Data differential signal input pin(Data lane 0)		IO
17	DSI_D0P	MIPI-DSI Data differential signal input pin(Data lane 0)		IO
18	GND			P
19	GND			P
20	GND			P
21	GND			P
22	TEST OUT	Test Output terminal	Please do not connect anything.	O
23	TEST OUT	Test Output terminal	Please do not connect anything.	O
24	VDD	Analog Power Supply	VDD = 2.8V (TYP)	P
25	VDD	Analog Power Supply	VDD = 2.8V (TYP)	P
26	GND			P
27	VCCIO	DSI and I/O Power Supply	VCCIO = 1.8V (TYP)	P
28	GND			P
29	RESETB	LCD Reset	L:Initialize	I
30	GND			P
31	GND			P
32	GND			P
33	GND			P
34	GND			P
35	GND			P
36	GND			P
37	GND			P
38	GND			P
39	GND			P
40	VLED	Power supply for Backlight LED		P
41	VLED	Power supply for Backlight LED		P
42	LED1	Backlight LED Cathode1		P
43	LED2	Backlight LED Cathode2		P
44	LED3	Backlight LED Cathode3		P
45	LED4	Backlight LED Cathode4		P
46	LED5	Backlight LED Cathode5		P

- Recommended connector: Panasonic coporation : AXT346124
- Please make sure to check a consistency between pin assignment in "3.2 Outward Form" and your connector pin assignment when designing your circuit.
Inconsistency in input signal assignment may cause a malfunction.
- Since FPC cable has gold plated terminals, gilt finish contact shoe connector is recommended.

5. Absolute Maximum Rating

GND=0V

Item	Symbol	Condition	Rating		Unit	Applicable terminal
			MIN	MAX		
Supply voltage	VDD	Ta=25 °C	-0.3	4.6	V	VDD
DSI and I/O Power Supply voltage	VCCIO		-0.3	4.6	V	VCCIO
Input voltage for logic	VI		-0.3	VCCIO+0.3	V	RESETB
DSI Input voltage	VDSIIN		-0.15	1.45	V	DSI_D0P/N , DSI_D1P/N DSI_CP/N
LED forward current	IL	Ta = 25 °C	-	30	mA	VLED, LED1~5
		Ta = 70 °C	-	14		
Storage temperature range	Tstg		-30	80	°C	
Storage humidity range	Hstg	Non condensing in an environmental moisture at or less than 40 °C 90%RH.				

6. Recommended Operating Conditions

GND=0V

Item	Symbol	Condition	Rating			Unit	Applicable terminal
			MIN	TYP	MAX		
Supply voltage	VDD		2.7	2.8	2.9	V	VDD
DSI and I/O Power Supply voltage	VCCIO		1.7	1.8	1.9	V	VCCIO
Input voltage for logic	VI		0	-	VCCIO	V	RESETB
DSI Input voltage	VI		-0.05	-	1.35	V	DSI_D0P/N DSI_D1P/N DSI_CP/N
Operational temperature range	Top	Note1,2	-20	25	70	°C	Panel surface temperature
Operating humidity range	Hop	Ta<=30 °C	20	-	80	%	
		Ta>30 °C	Non condensing in an environmental moisture at or less than 30 °C 80%RH.				

Note1: This monitor is operatable in this temperature range. With regard to optical characteristics, refer to Item 11."CHARACTERISTICS".

Note 2: Acceptable Forward Current to LED is up to 14 mA, when Ta=+70 °C.
Do not exceed Allowable Forward Current shown on the chart below.

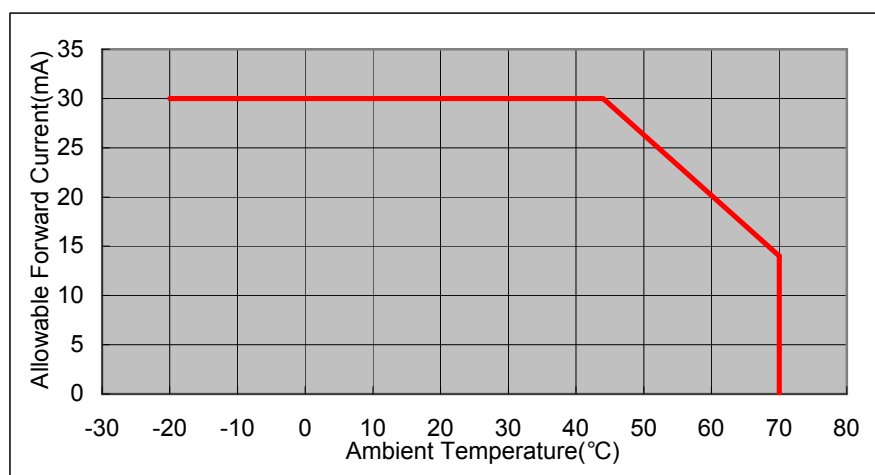

7. Characteristics

7.1 DC Characteristics

7.1.1 Display Module

(Unless otherwise noted, Ta=25 °C, VDD=2.8V, VCCIO=1.8V, GND=0V)

Item	Symbol	Condition	Rating			Unit	Applicable terminal
			MIN	TYP	MAX		
Input Signal Voltage	VIH	VCCIO=1.7-1.9V	0.7×VCCIO	-	VCCIO	V	RESETB
	VIL		0	-	0.3×VCCIO	V	
Operating Current	IDD	fDSICLK=150 MHz	-	11.2	22.4	mA	VDD
	ICCIO	Color bar display	-	3.5	7.0	mA	VCCIO
Sleep_mode Current	IDDS	Clock/Data=LP11	-	39	100	uA	VDD
	ICCIOS	Sleep_mode	-	17	100	uA	VCCIO

7.1.2 MIPI DSI Interface

Item	Symbol	Condition	Rating			Unit	Note
			MIN	TYP	MAX		
HS-RX	Differential input high threshold	VIDTH	-	-	110	mV	
	Differential input low threshold	VIDTL	-110	-	-	mV	
	Single-ended input high voltage	VIHHS	-	-	460	mV	
	Single-ended input low voltage	VILHS	-40	-	-	mV	
	Common-mode voltage HS receive mode	VCMRXD C	70	-	330	mV	
	Differential input impedance	ZID	80	100	125	Ohm	
LP-RX	Logic 1 input voltage	VIH	880	-	-	mV	
	Logic 0 input voltage	VIL	-	-	550	mV	
LP-TX	Thevenin output low level	VOL	-50	-	50	mV	
	Thevenin output high level	VOH	1.1	1.2	1.3	V	
	Output impedance of LP transmitter	ZOLP	110	-	-	Ohm	
CD-RX	Logic 1 contention threshold	VIHCD	450	-	-	mV	
	Logic 0 contention threshold	VILCD	-	-	220	mV	

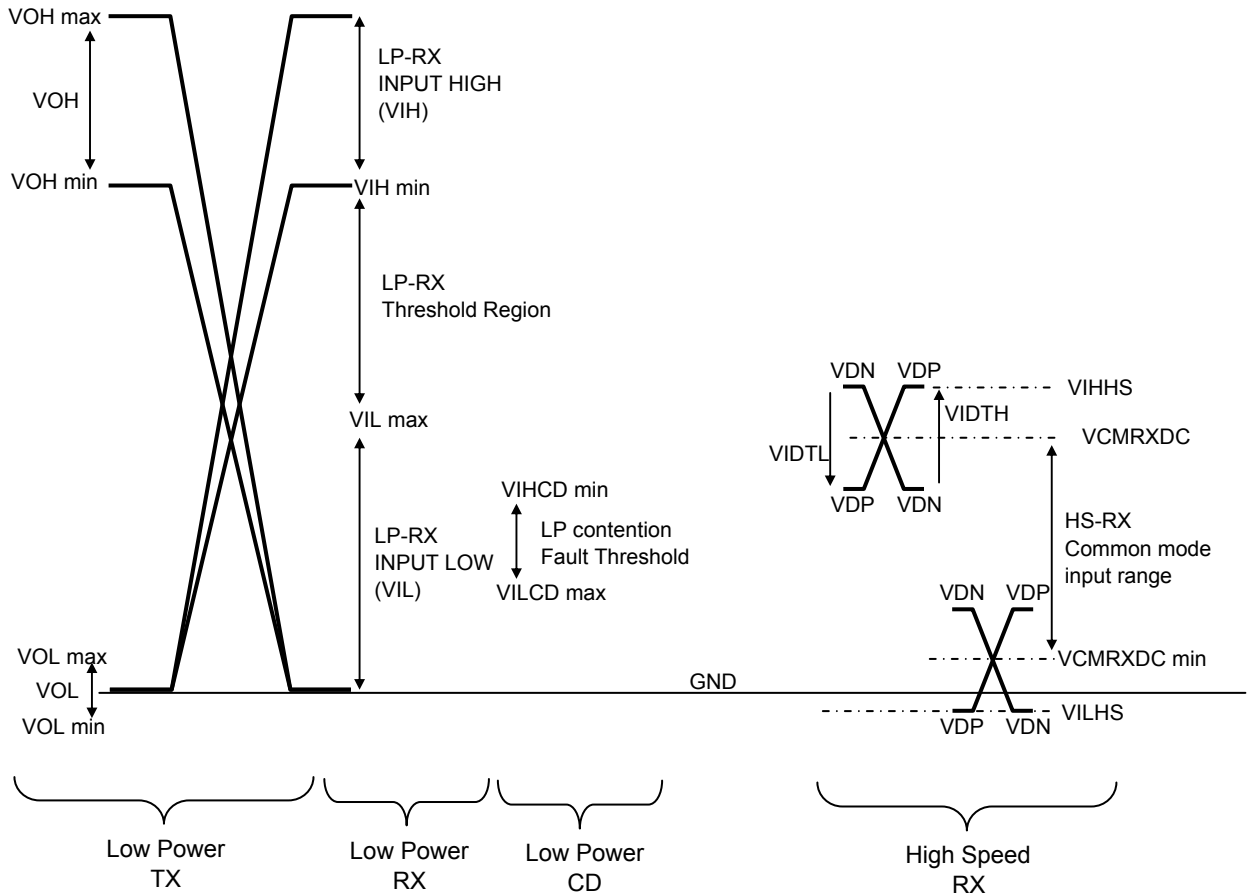

Fig.A The signal levels for the LP and HS .

7.1.3 Backlight

Item	Symbol	Condition	Rating			Unit	Applicable terminal
			MIN	TYP	MAX		
Forward current	IL25	Ta=25 °C	--	8.5	30	mA	VLED, LED1~5
	IL70	Ta=70 °C	--	--	14	mA	
Forward voltage *	VL	Ta=25 °C IL=8.5 mA	2.58	2.80	3.16	V	

*Reference only

7.2 AC Characteristics

7.2.1 HS-RX Specifications

(Unless otherwise noted, $T_a=25\text{ }^\circ\text{C}$, $V_{DD}=2.8\text{V}$, $V_{CCIO}=1.8\text{V}$, $GND=0\text{V}$)

Item	Symbol	Condition	Rating			Unit	Applicable terminal
			MIN	TYP	MAX		
DSICLK Frequency	f DSICLK	Fig.B	40	-	200	MHz	DSI_CP/N
DSICLK Cycle time	TCLKP		5.0	-	25.0	ns	
DSI Data Transfer Rate	UI		2.5	-	12.5	ns	DSI_D0P/N , DSI_D1P/N
	t DSIR		80	-	400	Mbps	
Data to Clock Setup Time	Tsetup		0.35	-	-	UI	DSI_D0P/N , DSI_D1P/N
Clock to Data Hold Time	Thold	0.25	-	-	UI	DSI_CP/N	

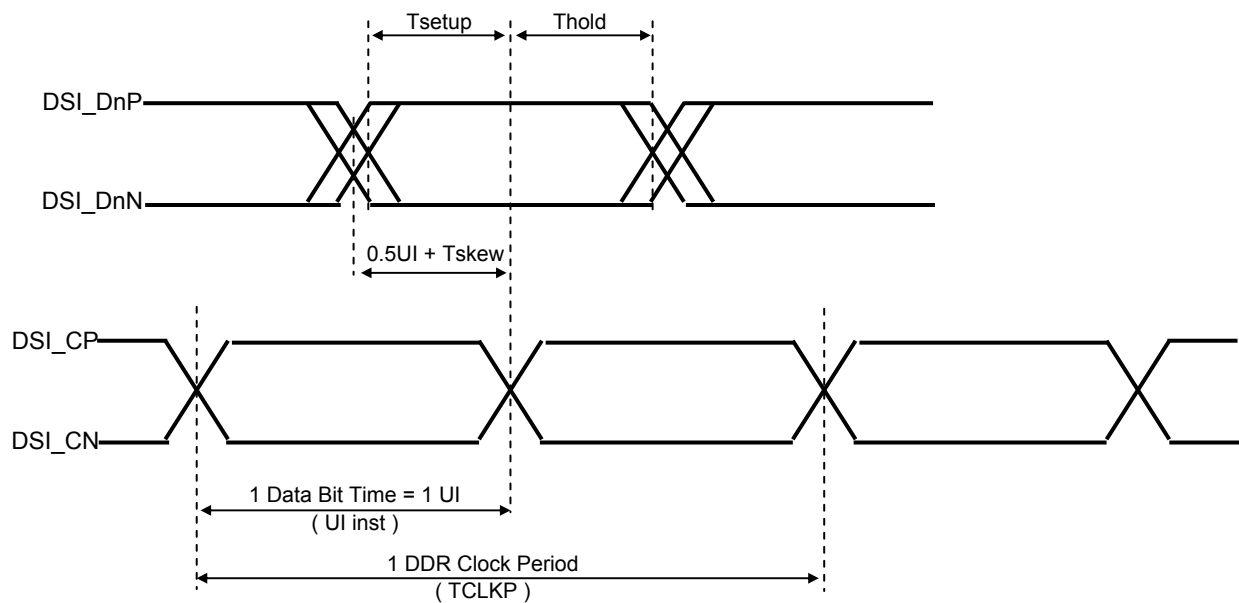

Fig.B Data to Clock Timing Definitions

7.2.2 LP-TX Specifications

(Unless otherwise noted, $T_a=25\text{ }^\circ\text{C}$, $V_{DD}=2.8\text{V}$, $V_{CCIO}=1.8\text{V}$, $GND=0\text{V}$)

Item	Symbol	Condition	Rating			Unit	Applicable terminal
			MIN	TYP	MAX		
15% - 85% rise time	TRLP		-	-	25	ns	DSI_D0P/N
85% - 15% fall time	TFLP		-	-	25	ns	DSI_D0P/N
Slew rate	$\Delta v / \Delta t_{SR}$	Clload = 70pF	30	-	500	mV/ns	DSI_D0P/N

7.2.3 RX/TX Specifications

(Unless otherwise noted, $T_a=25\text{ }^\circ\text{C}$, $V_{DD}=2.8\text{V}$, $V_{CCIO}=1.8\text{V}$, $GND=0\text{V}$)

Item	Description	Rating			Unit
		MIN	TYP	MAX	
$T_{HS-PREPARE}$	Time to drive LP00 to prepare for HS transmission	40 ns + 4UI	-	85 ns + 6UI, ≤ 100 ns	
$T_{HS-PREPARE} + T_{HS-ZERO}$	$T_{HS-PREPARE}$ + Time to drive HS0 before the SYNC sequence	145 ns + 10UI	-	-	
$T_{HS-TRAIL}$	Time to drive flipped differential state after last payload data bit of a HS transmission burst	$\max(n*8\text{UI}, 60\text{ ns} + n*4\text{UI})$	-	-	
$T_{HS-EXIT}$	Time to drive LP11 after HS burst	100	-	-	ns
T_{TA-GO}	Time to drive LP00 after Turnaround Request	$4*T_{LPTX}$			
$T_{TA-SURE}$	Time out before new TX side starts driving	T_{LPTX}	-	$2*T_{LPTX}$	
T_{TA-GET}	Time to drive LP00 by new TX	$5*T_{LPTX}$			
T_{LPX}	Length of any Low Power state period	50	-	-	ns
Ratio T_{LPX}	Ratio of $T_{LPX}(\text{MASTER})/T_{LPX}(\text{SLAVE})$ between Master and Slave side	2/3	-	3/2	
$T_{CLK-POST}$	Time that the transmitter shall continue sending HS clock after the last associated Data Lane has transitioned to LP mode	60 ns + 52UI	-	-	
$T_{CLK-PREPARE} + T_{CLK-ZERO}$	$T_{CLK-PREPARE}$ + time for lead HS-0 drive period before starting Clock	300	-	-	ns
$T_{CLK-PRE}$	Time that the HS clock shall be driven prior to any associated Data Lane beginning the transition from LP to HS mode	8	-	-	UI
$T_{CLK-PREPARE}$	Time to drive LP-00 to prepare for HS clock transmission	38	-	95	ns
$T_{CLK-TRAIL}$	Time to drive HS differential state after last payload clock bit of a HS transmission burst	60	-	-	ns
T_{EOT}	Time from start of $T_{HS-TRAIL}$ period to start of LP-11 state	-	-	105 ns + $n*12\text{UI}$	
T_{LPTX1}	Length of Low-Power TX state period in case of using DSI clock	-	$n*DSITX$	-	UI
T_{LPTX2}	Length of Low-Power TX state period in case of using internal OSC clock	-	1/fosc	-	ns

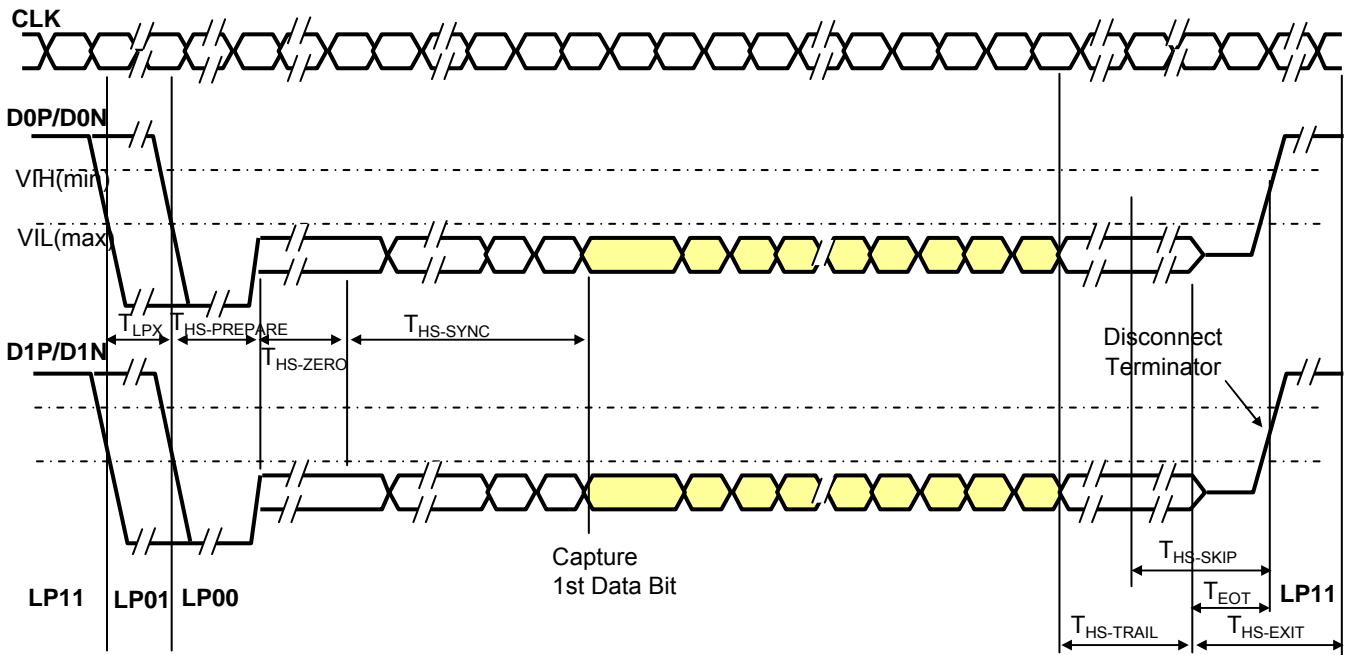

Fig.C HS Data Transmission in Bursts

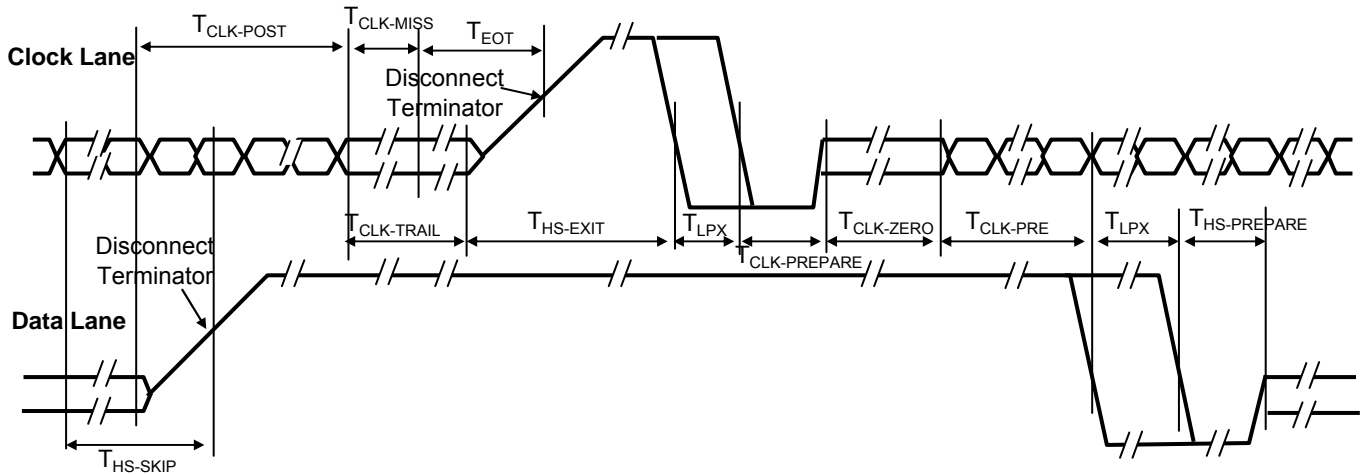

Fig.D Switching the Clock Lane between Clock Transmission and LP mode

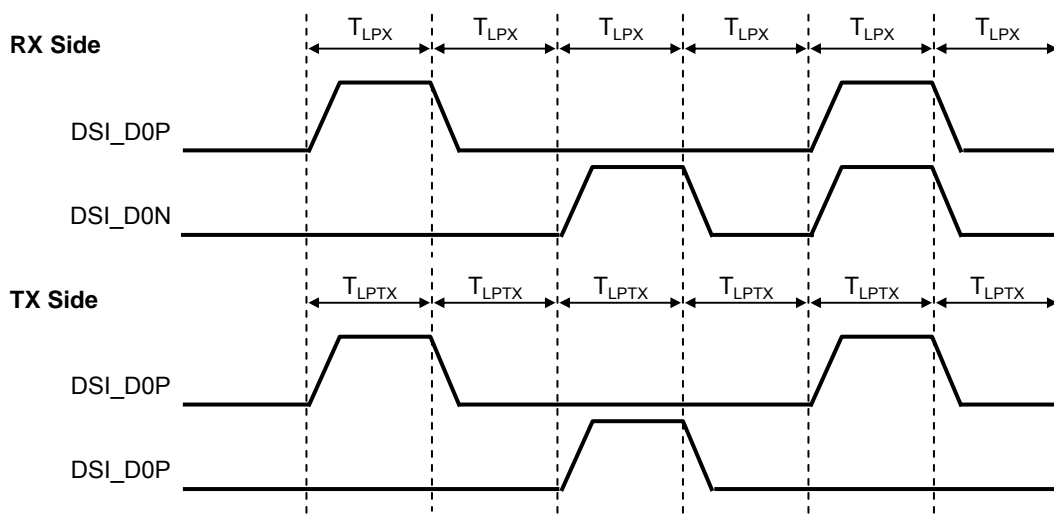

Fig.E DSI LP Mode

7.2.4 Reset input timing

Item	Symbol	Condition	Rating			Unit	Remark
			MIN	TYP	MAX		
Reset Low Pulse width	tRESW		10	-	-	us	
Reset Complete time	tREST	during Sleep In	-	-	5	ms	
		during Sleep Out	-	-	120	ms	

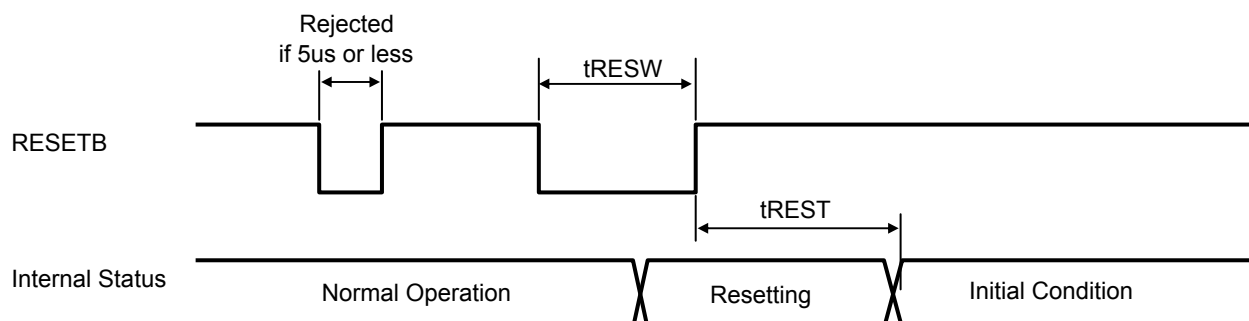

Fig.F RESETB input timing

7.3 Input Timing Characteristics

Item	Symbol	Condition	Rating			Unit	Remark
			MIN	TYP	MAX		
CLK Frequency	fPCLK	Fig.G	--	25.0	--	MHz	PCLK
VSYNC Frequency	Note fVSYNC		51.71	57.46	63.21	Hz	VSYNC
VSYNC Cycle	tv		809	824	850	H	
VSYNC Pulse Width	tw4H		3	8	--	H	
Vertical Back Porch	tvb		3	8	--	H	
Vertical Front Porch	tvf		3	8	--	H	
Vertical Display Period	tvdP		--	800	--	H	
HSYNC frequency	fHSYNC			--	48.6		kHz
HSYNC Cycle	th	504		528	568	CLK	
HSYNC Pulse Width	tw5H	5		16	78	CLK	
Horizontal Back Porch	thb	5		16	78	CLK	
Horizontal Front Porch	thf	5		16	78	CLK	
Horizontal data start Point	tw5H+thb	19		32	83	CLK	
Horizontal Blanking Period	tw5H+thb+thf	24		48	88	CLK	
Horizontal Display Period	thdp	--		480	--	CLK	

Note: This is recommended spec to get high quality picture on display. It is customer's risk to use out of this frequency.

7.4 Input Signal Timing Chart

-Vertical Timing

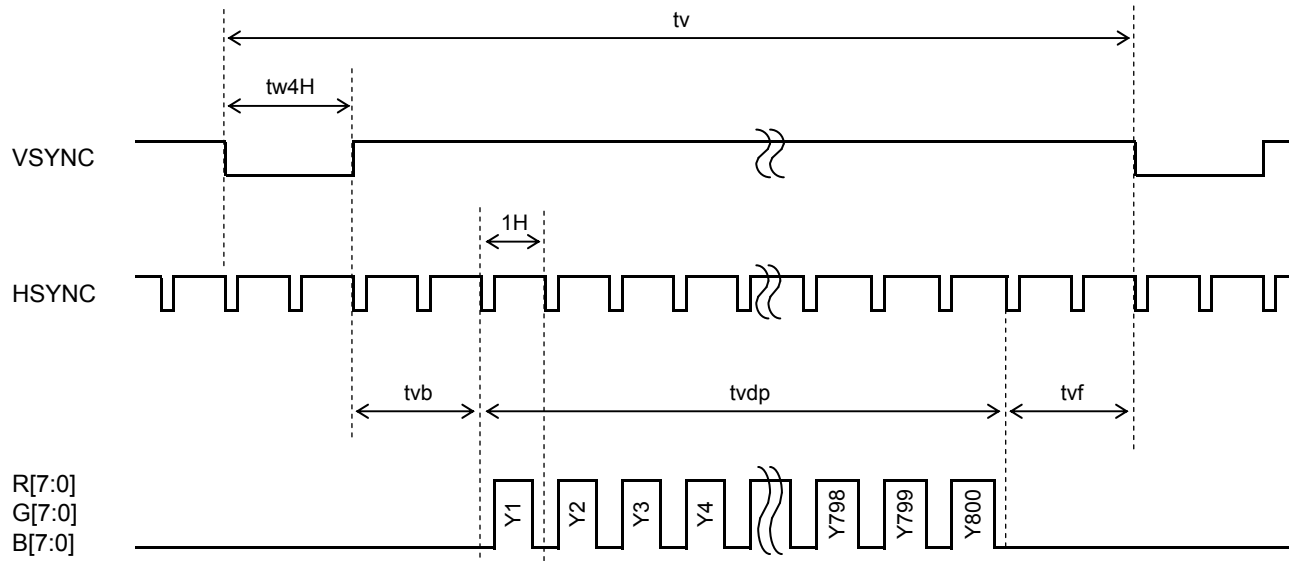

-Horizontal Timing

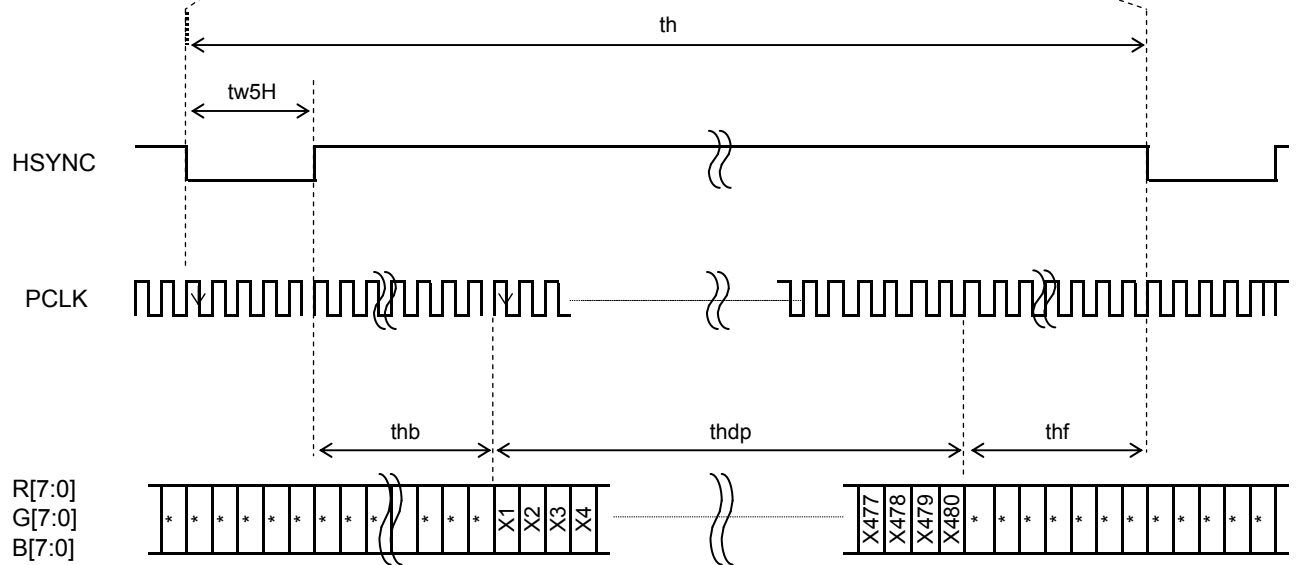

Fig.G Timing Characteristics of input signals

8. About MIPI Interface

8.1 Version

The DSI incorporated in the LCD-Driver complies with the following standards.

MIPI DSI : Version 1.01

MIPI D-PHY : Version 1.00

Data transfer mode : Video mode only.

Virtual Channel : Set to VC[1:0]=00.

8.2 DSI protocol

- Short packets specify the payload length using the Data Type field and are from 2 to 9 bytes in length. Short packets is used for most Command Mode commands and associated parameters.

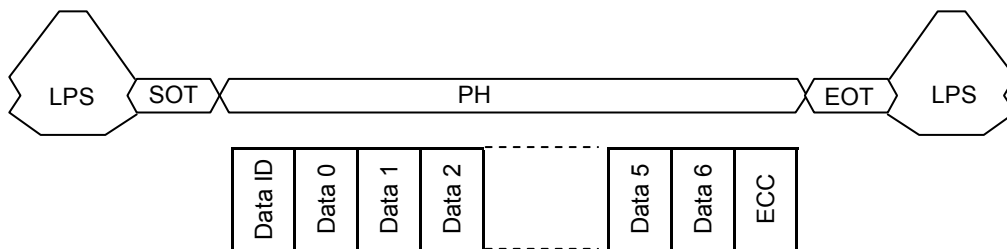

LPS : Low power state

SOT : Start of Transmission

PH : Packet Header

DI(Data ID) : Contain Virtual Channel Identifier and Data Type

ECC : Error Correction Code

- Long packets specify the payload length using a two-byte Word Count field and then the payload maybe 0 to 65,541 bytes in length. Long packets permit transmission of large blocks of pixel or other data.

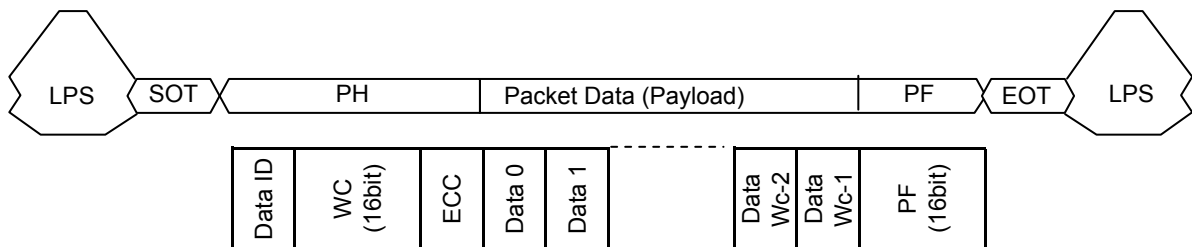

LPS : Low power state

SOT : Start of Transmission

PH : Packet Header

DI(Data ID) : Contain Virtual Channel Identifier and Data Type

WC(Word Count) : The receiver use WC to define packet end.

ECC : Error Correction Code

PF(Packet Footer) : Mean 16-bit Checksum.

8.3 Packet data types

LCD-Driver has the following restriction.

Generic short / Long Write Cmd is not supported.

It is only DCS Short / Long Write Cmd.

Processor to peripheral direction

Data Type Hex	Description	Size
01 h	Sync Event , V Sync Start (01,00,00,07)	Short
11 h	Sync Event , V Sync End (11,00,00,14)	Short
21 h	Sync Event , H Sync Start (21,00,00,12)	Short
31 h	Sync Event , H Sync End (31,00,00,01)	Short
22 h	Shut Down Peripheral Command (22,00,00,1E)	Short
32 h	Turn On Peripheral Command (32,00,00,0D)	Short
05 h	DCS WRITE , no parameters	Short
15 h	DCS WRITE , one parameters	Short
06 h	DCS READ , no parameters	Short
37 h	Set Maximum Return Packet Size	Short
08 h	End of Transmission Packet (08,0F,0F,01)	Short
09 h	Null Packet , no data	Long
19 h	Blanking Packet , no data	Long
39 h	DCS Long Write Command Packet	Long
0E h	Packed Pixel Stream , 16-bit RGB , 5-6-5 Format	Long
1E h	Packed Pixel Stream , 18-bit RGB , 6-6-6 Format	Long
2E h	Loosely Packed Pixel Stream , 18-bit RGB ,6-6-6 Format	Long
3E h	Packed Pixel Stream , 24-bit RGB , 8-8-8 Format	Long

Peripheral to processor direction

Data Type Hex	Description	Size
02 h	Acknowledge with Error Report	Short
1C h	DCS Long READ Response	Long

8.4 Packet Footer on the long packet

After Packet Data, Packet Footer is added in Long packet. Packet Footer adds CRC calculated from Packet Data as Checksum.

Checksum(2byte) = CRC(Packet Data)

$CRC = X^{16} + X^{12} + X^5 + X^0$

9. Sequence

9.1 Power-ON Sequence

PH :Packet Header

PD :Packet Data

PF:Packet Footer (=Checksum)

No.		Function	DNC	Command /Parameter	Type	Command/Parameter
		RESETB=0				
	Power on	VDD, VCCIO on				
	Wait	wait 10 msec or more				
		RESETB=1				
	MIPI signal state	keep CLKN, CLKP, D0N, D0P, D1N, D1P in STOP state (LP-11)				
	Wait	wait 10 msec or more				
1	Sleep out	Sleep out	0	11h	PH	[05 11 00 36]
	Wait	wait 100 msec or more				
2	Enable extended commands	Enable extended commands	0	B9h	PH	[39 04 00 2C]
Parameter 1		1	FFh	PD	[B9 FF 83 63]	
Parameter 2		1	83h	PF	[XX XX]	
Parameter 3		1	63h			
3	Set lane number/ operation mode	Two data lane, Sync Pulses mode *1	0	BAh	PH	[39, 0E, 00, 15]
Parameter 1		1	80h	PD	[BA 80 00 10 08 08 10 7E 6E 6D 0A 01 80 43]	
Parameter 2		1	00h	PF	[XX XX]	
Parameter 3		1	10h			
Parameter 4		1	08h			
Parameter 5		1	08h			
Parameter 6		1	10h			
Parameter 7		1	7Eh			
Parameter 8		1	6Eh			
Parameter 9		1	6Dh			
Parameter 10		1	0Ah			
Parameter 11		1	01h			
Parameter 12		1	80h			
Parameter 13		1	43h			
4	Memory access control	Memory access control	0	36h	PH	[15 36 00 29]
Parameter 1		1	00h			
5	Interface pixel format	Interface pixel format	0	3Ah	PH	[15 3A 70 28]
Parameter 1(24bit/pixel)		1	70h			
	Wait	wait 5 msec or more				
6	Set power	Set power	0	B1h	PH	[39 0D 00 13]
Parameter 1		1	78h	PD	[B1 78 24 04 02 02 03 10 10 34 3C 3F 3F]	
Parameter 2		1	24h	PF	[XX XX]	
Parameter 3		1	04h			
Parameter 4		1	02h			
Parameter 5		1	02h			
Parameter 6		1	03h			
Parameter 7		1	10h			
Parameter 8		1	10h			
Parameter 9		1	34h			
Parameter 10		1	3Ch			
Parameter 11		1	3Fh			
Parameter 12		1	3Fh			

PH :Packet Header

PD :Packet Data

PF:Packet Footer (=Checksum)

No.		Function	DNC	Command /Parameter	Type	Command/Parameter		
7	Set display waveform cycle	Set display waveform cycle	0	B4h	PH	[39 0A 00 36]		
		Parameter 1	1	00h	PD	[B4 00 08 6E 07 01 01 62 01 57]		
		Parameter 2	1	08h	PF	[XX XX]		
		Parameter 3	1	6Eh				
		Parameter 4	1	07h				
		Parameter 5	1	01h				
		Parameter 6	1	01h				
		Parameter 7	1	62h				
		Parameter 8	1	01h				
		Parameter 9	1	57h				
8	Set panel	Set panel	0	CCh	PH	[15 CC 0B 22]		
		Parameter 1	1	0Bh				
9	Set gamma curve related setting	Set gamma curve related setting	0	E0h	PH	[39 1F 00 29]		
		Parameter 1	1	01h	PD	[E0 01 48 4D 4E 58 F6 0B 4E 12 D5 15 95 55 8E 11 01 48 4D 55 5F FD 0A 4E 51 D3 17 95 96 4E 11]		
		Parameter 2	1	48h				
		Parameter 3	1	4Dh	PF	[XX XX]		
		Parameter 4	1	4Eh				
		Parameter 5	1	58h				
		Parameter 6	1	F6h				
		Parameter 7	1	0Bh				
		Parameter 8	1	4Eh				
		Parameter 9	1	12h				
		Parameter 10	1	D5h				
		Parameter 11	1	15h				
		Parameter 12	1	95h				
		Parameter 13	1	55h				
		Parameter 14	1	8Eh				
		Parameter 15	1	11h				
		Parameter 16	1	01h				
		Parameter 17	1	48h				
		Parameter 18	1	4Dh				
		Parameter 19	1	55h				
		Parameter 20	1	5Fh				
		Parameter 21	1	FDh				
		Parameter 22	1	0Ah				
		Parameter 23	1	4Eh				
		Parameter 24	1	51h				
		Parameter 25	1	D3h				
		Parameter 26	1	17h				
		Parameter 27	1	95h				
		Parameter 28	1	96h				
		Parameter 29	1	4Eh				
		Parameter 30	1	11h				
			Wait	wait 5 msec or more				
		10	Display on	Display on	1	29h	PH	[05 29 00 1C]
		11	Video stream					...
						...		
						...		

*1 The described value is Sync Pulses mode in DSI interface.

If you want to changes the lane number/ operation mode. Please follow the under packet to change it.

Two data lane, Sync Pulses mode :

Packet header [39, 0E, 00, 15],

Packet data [BA 80 00 10 08 08 10 7E 6E 6D 0A 01 80 43],

Packet footer[XX XX]

Two data lane, Sync Events mode/Burst mode :

Packet header [39, 0E, 00, 15],

Packet data [BA 80 00 10 08 08 10 7E 6E 6D 0A 01 84 43],

Packet footer[XX XX]

One data lane, Sync Pulses mode :

Packet header [39, 0E, 00, 15],

Packet data [BA 80 00 10 08 08 10 7E 6E 6D 0A 00 80 43],

Packet footer[XX XX]

One data lane, Sync Events mode/Burst mode :

Packet header [39, 0E, 00, 15],

Packet data [BA 80 00 10 08 08 10 7E 6E 6D 0A 00 84 43],

Packet footer[XX XX]

9.2 Power-OFF Sequence

PH :Packet Header

PD :Packet Data

PF:Packet Footer (=Checksum)

No.		Function	DNC	Command /Parameter	Type	Command/Parameter
1	Display off	Display off	0	28h	PH	[05 28 00 06]
	Wait	wait 5 msec or more				
2	Sleep in	Sleep in	0	10h	PH	[05 10 00 2C]
	Wait	wait 2 frames or more				
3	Video signals	Video signals stop				

↓
Power off

9.3 Sleep Sequence

No.		Function	DNC	Command /Parameter	Type	Command/Parameter
1	Sleep in	Sleep in	0	10h	PH	[05 10 00 2C]
	Wait	wait 2 frames or more				
2	Video signals	Video signals stop				

9.4 Sleep Release Sequence

No.		Function	DNC	Command /Parameter	Type	Command/Parameter
1	Video signals	Video signals start				
	Wait	wait 2 frames or more				
2	Sleep out	Sleep out	0	11h	PH	[05 11 00 36]

9.5 Power ON/OFF timing

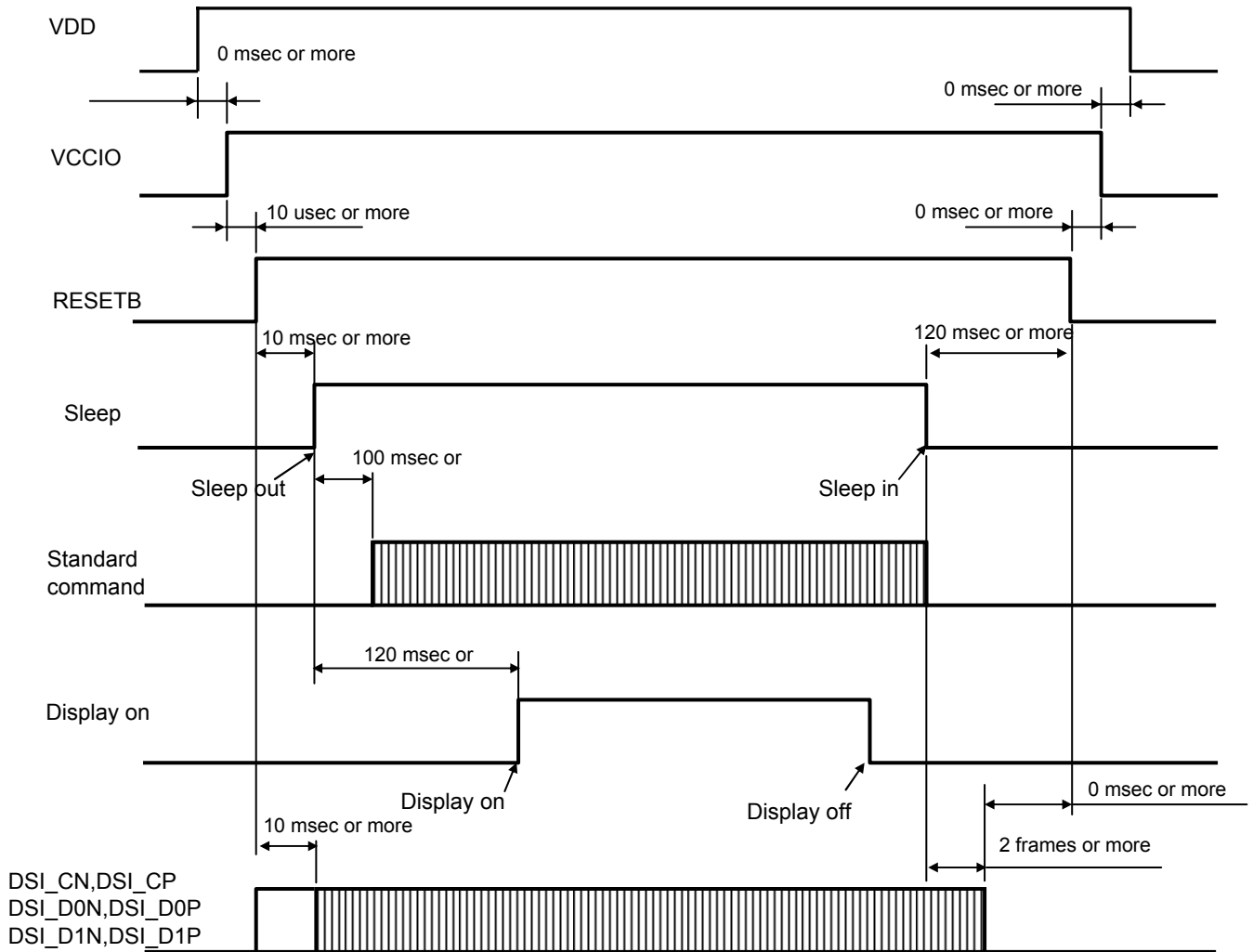

9.6 Refresh Sequence

PH :Packet Header

PD :Packet Data

PF:Packet Footer (=Checksum)

No.		Function	DNC	Command /Parameter	Type	Command/Parameter
1	Sleep out	Sleep out	0	11h	PH	[05 11 00 36]
	Wait	wait 100 msec or more				
2	Enable extended commands	Enable extended commands	0	B9h	PH	[39 04 00 2C]
		Parameter 1	1	FFh	PD	[B9 FF 83 63]
		Parameter 2	1	83h	PF	[XX XX]
		Parameter 3	1	63h		
3	Set lane number/ operation mode	Two data lane, Sync Pulses mode *1	0	BAh	PH	[39, 0E, 00, 15]
		Parameter 1	1	80h	PD	[BA 80 00 10 08 08 10 7E 6E 6D 0A 01 80 43]
		Parameter 2	1	00h	PF	[XX XX]
		Parameter 3	1	10h		
		Parameter 4	1	08h		
		Parameter 5	1	08h		
		Parameter 6	1	10h		
		Parameter 7	1	7Eh		
		Parameter 8	1	6Eh		
		Parameter 9	1	6Dh		
		Parameter 10	1	0Ah		
		Parameter 11	1	01h		
		Parameter 12	1	80h		
		Parameter 13	1	43h		
4	Memory access control	Memory access control	0	36h	PH	[15 36 00 29]
		Parameter 1	1	00h		
5	Interface pixel format	Interface pixel format	0	3Ah	PH	[15 3A 70 28]
		Parameter 1(24bit/pixel)	1	70h		
	Wait	wait 5 msec or more				
6	Set power	Set power	0	B1h	PH	[39 0D 00 13]
		Parameter 1	1	78h	PD	[B1 78 24 04 02 02 03 10 10 34 3C 3F 3F]
		Parameter 2	1	24h	PF	[XX XX]
		Parameter 3	1	04h		
		Parameter 4	1	02h		
		Parameter 5	1	02h		
		Parameter 6	1	03h		
		Parameter 7	1	10h		
		Parameter 8	1	10h		
		Parameter 9	1	34h		
		Parameter 10	1	3Ch		
		Parameter 11	1	3Fh		
		Parameter 12	1	3Fh		

PH :Packet Header

PD :Packet Data

PF:Packet Footer (=Checksum)

No.		Function	DNC	Command /Parameter	Type	Command/Parameter
7	Set display waveform cycle	Set display waveform cycle	0	B4h	PH	[39 0A 00 36]
		Parameter 1	1	00h	PD	[B4 00 08 6E 07 01 01 62 01 57]
		Parameter 2	1	08h	PF	[XX XX]
		Parameter 3	1	6Eh		
		Parameter 4	1	07h		
		Parameter 5	1	01h		
		Parameter 6	1	01h		
		Parameter 7	1	62h		
		Parameter 8	1	01h		
		Parameter 9	1	57h		
8	Set panel	Set panel	0	CCh	PH	[15 CC 0B 22]
		Parameter 1	1	0Bh		
9	Set gamma curve related setting	Set gamma curve related setting	0	E0h	PH	[39 1F 00 29]
		Parameter 1	1	01h	PD	[E0 01 48 4D 4E 58 F6 0B 4E 12 D5 15 95 55 8E 11 01 48 4D 55 5F FD 0A 4E 51 D3 17 95 96 4E 11]
		Parameter 2	1	48h		
		Parameter 3	1	4Dh	PF	[XX XX]
		Parameter 4	1	4Eh		
		Parameter 5	1	58h		
		Parameter 6	1	F6h		
		Parameter 7	1	0Bh		
		Parameter 8	1	4Eh		
		Parameter 9	1	12h		
		Parameter 10	1	D5h		
		Parameter 11	1	15h		
		Parameter 12	1	95h		
		Parameter 13	1	55h		
		Parameter 14	1	8Eh		
		Parameter 15	1	11h		
		Parameter 16	1	01h		
		Parameter 17	1	48h		
		Parameter 18	1	4Dh		
		Parameter 19	1	55h		
		Parameter 20	1	5Fh		
		Parameter 21	1	FDh		
		Parameter 22	1	0Ah		
		Parameter 23	1	4Eh		
		Parameter 24	1	51h		
		Parameter 25	1	D3h		
		Parameter 26	1	17h		
		Parameter 27	1	95h		
		Parameter 28	1	96h		
		Parameter 29	1	4Eh		
		Parameter 30	1	11h		
	Wait	wait 5 msec or more				
10	Display on	Display on	1	29h	PH	[05 29 00 1C]

10. LED Circuit

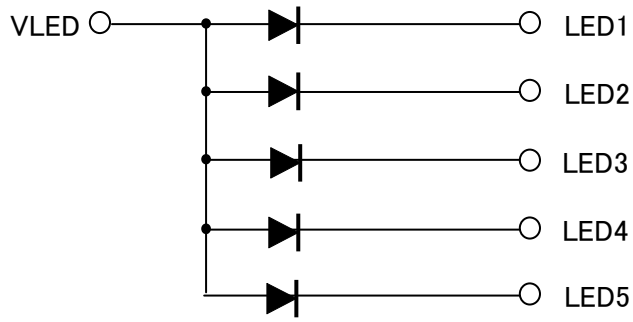

11. Characteristics

11.1 Optical Characteristics

< Measurement Condition >

Measuring instruments: CS1000 (KONICA MINOLTA) , LCD7200(OTSUKA ELECTRONICS) ,
EZcontrast160D (ELDIM)

Driving condition: VDD=2.8V, VCCIO=1.8V
Optimized VCOMDC

Backlight: IL=8.5mA

Measured temperature: Ta=25° C

Item		Symbol	Condition	MIN	TYP	MAX	Unit	Note No.	Remark
Response time	Rise time	TON	[Data]= 00h→FFh	—	—	40	ms	1	※
	Fall time	TOFF	[Data]= FFh→00h	—	—	60	ms		
Contrast ratio	Backlight ON	CR	[Data]= FFh / 00h	600	1000	—		2	
	Backlight OFF			—	2.9	—			
Viewing angle	Left	θL	[Data]= FFh / 00h CR ≥ 10	80	—	—	deg	3	※
	Right	θR		80	—	—	deg		
	Up	φU		80	—	—	deg		
	Down	φD		80	—	—	deg		
White Chromaticity	x		White chromaticity range					4	
	y								
Burn-in				No noticeable burn-in image shall be observed after 2 hours of window pattern display.				5	
Center brightness			[Data]=FFh	240	380	—	cd/m ²	6	
Brightness distribution			[Data]=FFh	70	—	—	%	7	

* Note number 1 to 7: Refer to the APPENDIX of "Reference Method for Measuring Optical Characteristics".

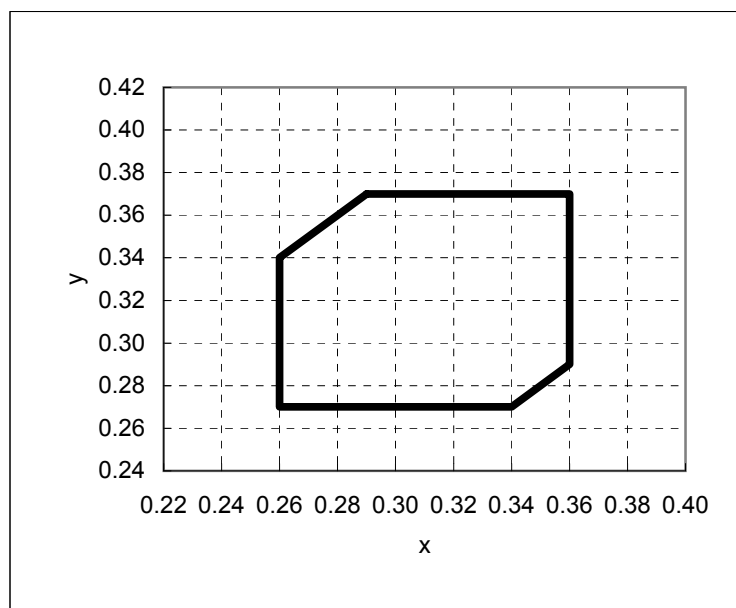

White Chromaticity Range

【White Chromaticity Range】

x	y
0.29	0.37
0.26	0.34
0.26	0.27
0.34	0.27
0.36	0.29
0.36	0.37

11.2 Temperature Characteristics

< Measurement Condition >

Measuring instruments: CS1000 (KONICA MINOLTA) , LCD7200(OTSUKA ELECTRONICS)

Driving condition: VDD=2.8V,VCCIO=1.8V

Optimized VCOMDC

Backlight: IL=8.5mA

Item			Specification		Remark
			Ta=-20°C	Ta=70°C	
Contrast ratio		CR	200 or more	200 or more	Backlight ON
Response time	Rise time	TON	400 msec or less	30 msec or less	
	Fall time	TOFF	600 msec or less	50 msec or less	
Display Quality			No noticeable display defect or ununiformity should be observed.		

12. Criteria of Judgment

12.1 Defective Display and Screen Quality

Test Condition: Observed TFT-LCD monitor from front during operation with the following conditions

Driving Signal Raster Pattern (RGB, white, black)

Signal condition [Data]: 00h, BCh, FFh (3steps)

Observation distance 30 cm

Illuminance 200 to 350 lx

Backlight IL=8.5mA

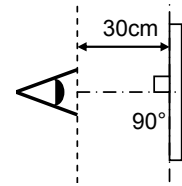

Defect item	Defect content		Criteria	
Display Quality	Line defect	Black, white or color line, 3 or more neighboring defective dots	Not exists	
	Dot defect	Uneven brightness on dot-by-dot base due to defective TFT or CF, or dust is counted as dot defect (brighter dot, darker dot) High bright dot: Visible through 2% ND filter at [Data]=00h Low bright dot: Visible through 5% ND filter at [Data]=00h Dark dot: Appear dark through white display at [Data]=BCh Invisible through 5% ND filter at [Data]=00h	Refer to table 1	
			Acceptable	
Screen Quality	Dirt	Uneven brightness (white stain, black stain etc)	Invisible through 5% ND filter at Black screen. Invisible through 1% ND filter at other screen.	
	Foreign particle	Point-like	$0.25\text{mm} < \phi$	N=0
			$0.20\text{mm} < \phi \leq 0.25\text{mm}$	$N \leq 2$
			$\phi \leq 0.20\text{mm}$	Acceptable
	Liner	$3.0\text{mm} < \text{length and } 0.08\text{mm} < \text{width}$	N=0	
$\text{length} \leq 3.0\text{mm or width} \leq 0.08\text{mm}$		Acceptable		
Others		Use boundary sample for judgment when necessary		

$\phi(\text{mm})$: Average diameter = (major axis + minor axis)/2
Permissible number: N

Table 1

Area	High bright dot	Low bright dot	Dark dot	Total	Criteria
A	0	2	2	3	Permissible distance between same color bright dots (includes neighboring dots): 3 mm or more
B	2	4	4	6	Permissible distance between same color high bright dots (includes neighboring dots): 5 mm or more
Total	2	4	4	6	

<Portrait model>

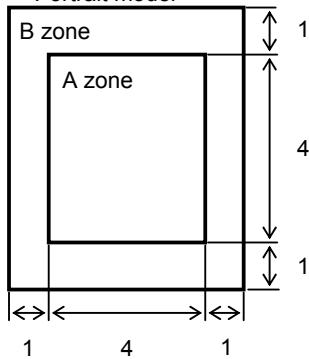

Division of A and B areas
B area: Active area
Dimensional ratio between A and B areas: 1: 4: 1
(Refer to the left figure)

12.2 Screen and Other Appearance

Testing conditions

Observation distance	30cm
Illuminance	1200~2000 lx

Item	Criteria	Remark
Polarizer Flaw Stain Bubble Dust Dent	Ignore invisible defect when the backlight is on.	Applicable area: Active area only (Refer to the section 3.2 "Outward form")
S-case	No functional defect occurs	
FPC cable	No functional defect occurs	

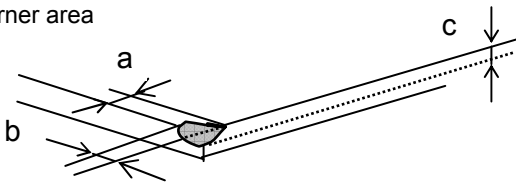
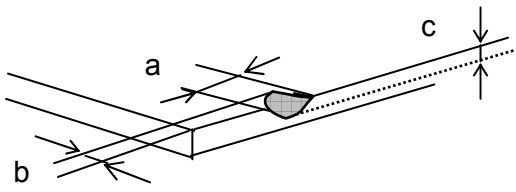
Item	Appearance	Criteria
Glass chipping	Corner area 	Unit:mm $a \leq 3$ $b \leq 3$ $c \leq t$ (t: glass thickness) $a, b \leq 0.5$ is acceptable $n \leq 2$
	Others 	Unit:mm $a \leq 5$ $b \leq 1$ $c \leq t$ (t: glass thickness) $a, b \leq 0.5$ is acceptable Maximum permissible number of chipping off on a side is 5.
	Progressive crack	None

13. Reliability Test

Test item		Test condition		number of failures /number of examinations
Durability test	High temperature storage	Ta=80° C	240hr	0/3
	Low temperature storage	Ta=-30° C	240hr	0/3
	High temperature & high humidity storage	Ta=60° C, RH=90% non condensing	240hr	0/3
	High temperature operation	Tp=70° C	240hr	0/3
	Low temperature operation	Tp=-20° C	240hr	0/3
	High temp & humid operation	Tp=40° C, RH=90% non condensing	240hr	0/3
	Thermal shock storage	-30←→80° C(30min/30min)	100 cycles	0/3
Mechanical environmental test	Electrostatic discharge test (Non operation)	Confirms to EIAJ ED-4701/300 C=200pF,R=0Ω,V=±200V Each 3 times of discharge on and power supply and other terminals.		0/3
	Surface discharge test (Non operation)	C=250pF, R=100Ω, V=±6kV Each 5 times of discharge in both polarities on the center of screen with the case grounded.		0/3
	Vibration test	Total amplitude 1.5mm, f=10~55Hz, X,Y,Z directions for each 2 hours		0/3
	Impact test	Use ORTUS TECHNOLOGY original jig (see next page)and make an impact with peak acceleration of 1000m/s ² for 6 msec with half sine-curve at 3 times to each X, Y, Z directions in conformance with JIS C 60068-2-27-2011.		0/3
Packing test	Packing vibration-proof test	Acceleration of 19.6m/s ² with frequency of 10→55→10Hz, X,Y, Zdirection for each 30 minutes		0/1 Packing
	Packing drop test	Drop from 75cm high. 1 time to each 6 surfaces, 3 edges, 1 corner		0/1 Packing

Note: Ta=ambient temperature Tp=Panel temperature

※ The profile of high temperature/humidity storage and High Temperature/humidity operation (Pure water of over 10MΩ·cm shall be used.)

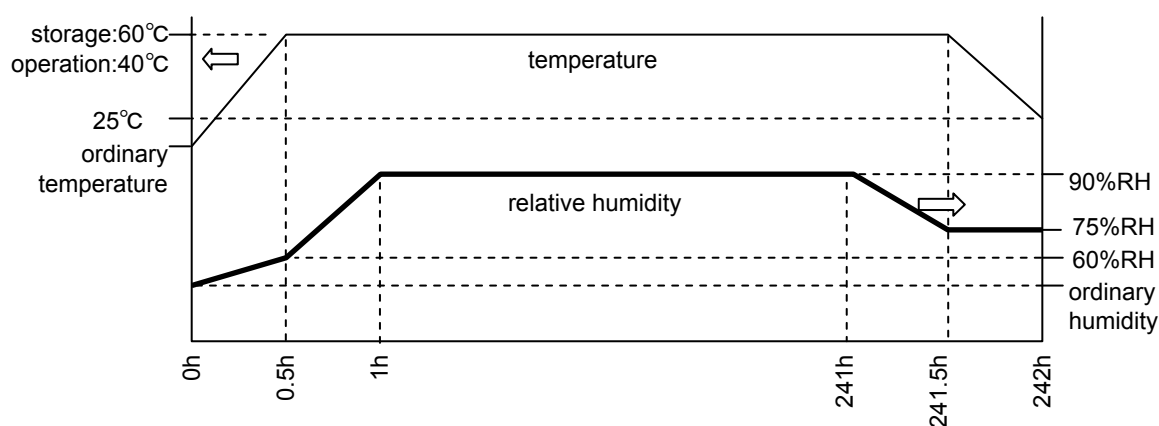
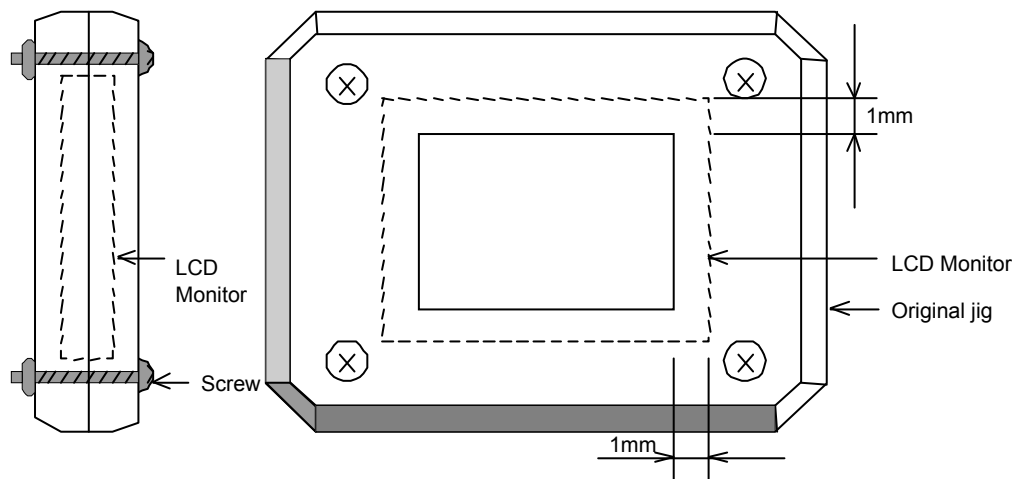

Table2.Reliability Criteria

The parameters should be measured after leaving the monitor at the ordinary temperature for 24 hours or more after the test completion.

item	Standard	Remarks
Display quality	No visible abnormality shall be seen. (Except for unevenness by PoI deterioration.)	
Contrast ratio	200 or more	Backlight ON

ORTUS TECHNOLOGY Original Jig



14. Packing Specifications

- Step1. Each lower product is placed in one of the cut-outs of the tray with the LCD surface facing upward, and foam sheet is put on products, and upper products are placed facing downward. (30 pieces / 1 tray)
- Step2. 5 trays containing products are stacked. One empty tray is put on the top of the stack of 5 trays.
- Step3. Driers are placed on the top tray as shown in the drawing. The stack of 6 trays is wrapped in a sealing bag.
- Step4. The opening of the sealing bag is folded and sealed with air out from the sealing bag. The B sheet A and sealed adhesive tape.
- Step5. A inner board is placed on the bottom of the sealing bag covered with the B sheet A. The inner board and the sealing bag covered with the B sheet A are inserted into an outer carton.
- Step6. The outer carton is sealed with packing tape as shown in the drawing. The model number, quantity of products, and shipping date are printed on the outer carton. If necessary, shipping labels or impression markings are put on the outer carton.
- Step7. The outer carton is inserted into a extra outer carton with same direction.
- Step8. The extra outer carton is sealed with packing tape as shown in the drawing. The model number, quantity of products, and shipping date are printed on the extra outer carton. If necessary, shipping labels or impression markings are put on the extra outer carton.

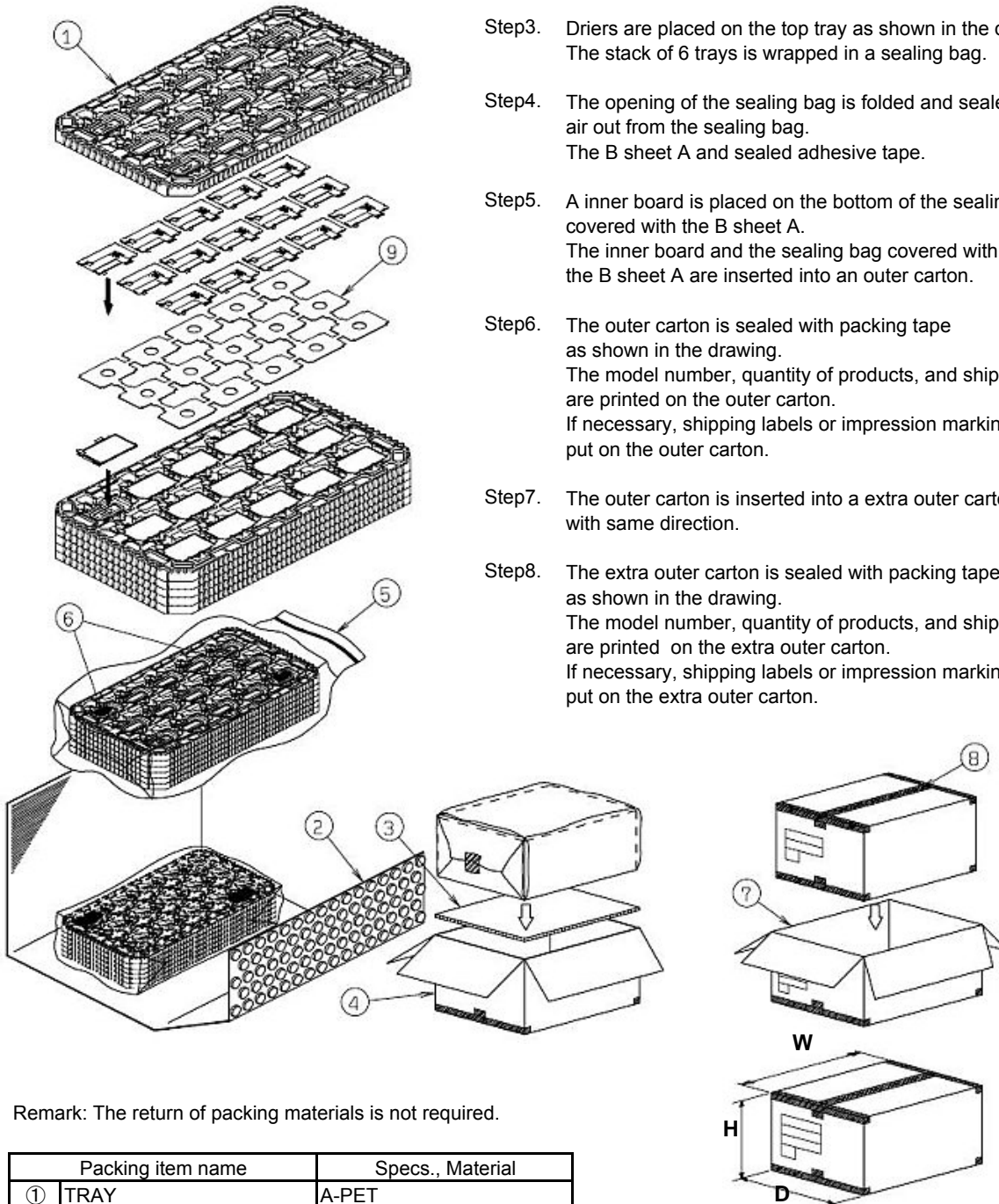

Remark: The return of packing materials is not required.

	Packing item name	Specs., Material
①	TRAY	A-PET
②	B SHEET A	Anti-static air bubble sheet
③	INNER BOARD	Corrugated cardboard
④	OUTER CARTON	Corrugated cardboard
⑤	SEALING BAG	
⑥	Drier	Moisture absorber
⑦	EXTRA OUTER CARTON	Corrugated cardboard
⑧	SEALING BAG	
⑨	FOAM SHEET	Anti-static polyethylene

Dimension of extra outer carton	
D : Approx.	(337mm)
W : Approx.	(618mm)
H : Approx.	(179mm)
Quantity of products packed in one carton:	150
Gross weight : Approx.	5.1kg

15. Handling Instruction

15.1 Cautions for Handling LCD panels

**Caution**

- (1) Do not make an impact on the LCD panel glass because it may break and you may get injured from it.
- (2) If the glass breaks, do not touch it with bare hands.
(Fragment of broken glass may stick you or you cut yourself on it.)
- (3) If you get injured, receive adequate first aid and consult a medial doctor.
- (4) Do not let liquid crystal get into your mouth.
(If the LCD panel glass breaks, try not let liquid crystal get into your mouth even toxic property of liquid crystal has not been confirmed.)
- (5) If liquid crystal adheres, rinse it out thoroughly.
(If liquid crystal adheres to your cloth or skin, wipe it off with rubbing alcohol or wash it thoroughly with soap. If liquid crystal gets into eyes, rinse it with clean water for at least 15 minutes and consult an eye doctor.)
- (6) If you scrap this products, follow a disposal standard of industrial waste that is legally valid in the community, country or territory where you reside.
- (7) Do not connect or disconnect this product while its application products is powered on.
- (8) Do not attempt to disassemble or modify this product as it is precision component.
- (9) If a part of soldering part has been exposed, and avoid contact (short-circuit) with a metallic part of the case etc. about FPC of this model, please.
Please insulate it with the insulating tape etc. if necessary.
The defective operation is caused, and there is a possibility to generation of heat and the ignition.
- (10) Since excess current protection circuit is not built in this TFT module, there is the possibility that LCD module or peripheral circuit become feverish and burned in case abnormal operation is generated.
We recommend you to add excess current protection circuit to power supply.
- (11) The devices on the FPC are damageable to electrostatic discharge, because the terminals of the devices are exposed.
Wear grounded wrist-straps and use electrostatic neutralization blowers to prevent static charge and discharge when handling the TFT monitors.
Designate an appropriate operating area, and set equipment, tools, and machines properly when handling this product.



Caution This mark is used to indicate a precaution or an instruction which, if not correctly observed, may result in bodily injury, or material damages alone.

15.2 Precautions for Handling

- 1) Wear finger tips at incoming inspection and for handling the TFT monitors to keep display quality and keep the working area clean.
Do not touch the surface of the monitor as it is easily scratched.
- 2) Wear grounded wrist-straps and use electrostatic neutralization blowers to prevent static charge and discharge when handling the TFT monitors as the LED in this TFT monitors is damageable to electrostatic discharge. Designate an appropriate operating area, and set equipment, tools, and machines properly when handling this product.
- 3) Avoid strong mechanical shock including knocking, hitting or dropping to the TFT monitors for protecting their glass parts. Do not use the TFT monitors that have been experienced dropping or strong mechanical shock.
- 4) Do not use or storage the TFT monitors at high temperature and high humidity environment. Particularly, never use or storage the TFT monitors at a location where condensation builds up.
- 5) Avoid using and storing TFT monitors at a location where they are exposed to direct sunlight or ultraviolet rays to prevent the LCD panels from deterioration by ultraviolet rays.
- 6) Do not stain or damage the contacts of the FPC cable .
FPC cable needs to be inserted until it can reach to the end of connector slot.
During insertion, make sure to keep the cable in a horizontal position to avoid an oblique insertion.
Otherwise, it may cause poor contact or deteriorate reliability of the FPC cable.
- 7) The FPC cable is a design very weak to the bend and the pull as it is fixed with the tape.
Do not bend or pull the FPC cable or carry the TFT monitor by holding the FPC cable.
- 8) Peel off the protective film on the TFT monitors during mounting process.
Refer to the section 15.5 on how to peel off the protective film.
We are not responsible for electrostatic discharge failures or other defects occur when peeling off the protective film.
- 9) Please make it to the structure to suppress surroundings of the front polarizer for the display irregularity prevention.

15.3 Precautions for Operation

- 1) Since this TFT monitors are not equipped with light shielding for the driver IC, do not expose the driver IC to strong lights during operation as it may cause functional failures.
- 2) In case of powering up or powering off this LCD module, be sure to comply the sequence as instructed in this specification.
- 3) Do not plug in or out the FPC cable while power supply is switch on.
Plug the FPC cable in and out while power supply is switched off.
- 4) Do not operate the TFT monitors in the strong magnetic field. It may break the TFT monitors.
- 5) Do not display a fixed image on the screen for a long time.
Use a screen-saver or other measures to avoid a fixed image displayed on the screen for a long time.
Otherwise, it may cause burn-in image on the screen due the characteristics of liquid crystal.

15.4 Storage Condition for Shipping Cartons

Storage environment

- Temperature 0 to 40° C
- Humidity 60%RH or less
No-condensing occurs under low temperature with high humidity condition.
- Atmosphere No poisonous gas that can erode electronic components and/or wiring materials should be detected.
- Time period 1 year
- Unpacking To prevent damages caused by static electricity, anti-static precautionary measures (e.g. earthing, anti-static mat) should be implemented.
After unpack, keep product in the appropriate condition, otherwise bubble seal of Protective film may be printed on Polarizer.
- Maximum piling up 7 cartons

*Conditions to storage after unpacking

Storage environment

- Temperature 0 to 40° C
- Humidity 60%RH or less
No-condensing occurs under low temperature with high humidity condition.
- Atmosphere No poisonous gas that can erode electronic components and/or wiring materials should be detected.
- Time period 1 year (Shelf life)
- Others Keep/ store away from direct sunlight
Storage goods on original tray made by ORTUS.

15.5 Precautions for Peeling off the Protective film

The followings work environment and work method are recommended to prevent the TFT monitors from static damage or adhesion of dust when peeling off the protective films.

A) Work Environment

- a) Humidity: 50 to 70 %RH, Temperature 15 to 27 ° C
- b) Operators should wear conductive shoes, conductive clothes, conductive finger tips and grounded wrist-straps.
Use an electrostatic neutralization blower.
Anti-static treatment should be implemented to work area's floor.
- c) Use a room shielded against outside dust with sticky floor mat laid at the entrance to eliminate dirt.

B) Work Method

The following procedures should taken to prevent the driver ICs from charging and discharging.

- a) Use an electrostatic neutralization blower to blow air on the TFT monitors to its lower right when FPC is placed at the bottom.
Optimize direction of the blowing air and the distance between the TFT monitors and the electrostatic neutralization blower.
- b) Peel off the tab slowly (spending more than 2 secs to complete) by pulling it to opposite direction.

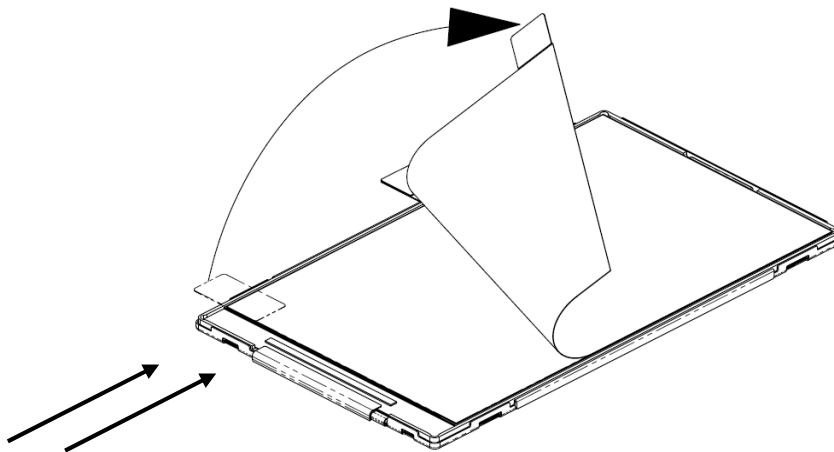

Blower wind direction (Set an ion blower with its adequate conditions.)

15.6 Warranty

ORTUS is only liable to defective goods which is stored and used under the condition complying with this specifications and returned within 1 (one) year.

Warranty caused by manufacturing defect shall be conducted by replacement of goods or refundment at unit price.

APPENDIX

Reference Method for Measuring Optical Characteristics and Performance

1. Measurement Condition (Backlight ON)

Measuring instruments: CS1000 (KONICA MINOLTA) , LCD7200(OTSUKA ELECTRONICS) ,EZcontrast160D (ELDIM)

Driving condition: Refer to the section "Optical Characteristics"

Measured temperature: 25° C unless specified

Measurement system: See the chart below. The luminance meter is placed on the normal line of measurement system.

Measurement point: At the center of the screen unless otherwise specified

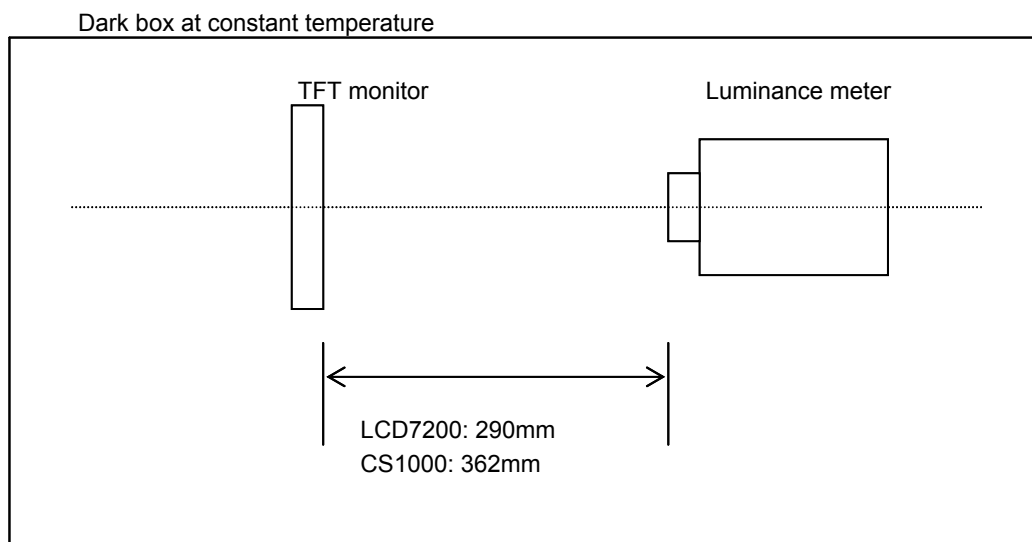

Measurement is made after 30 minutes of lighting of the backlight.

Measurement point: At the center point of the screen

Brightness distribution: 9 points shown in the following drawing.

<Portrait model>

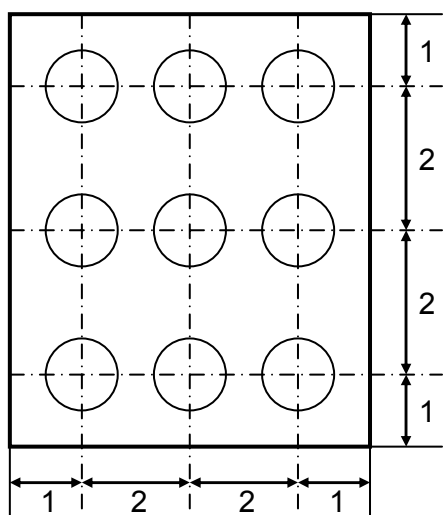

Dimensional ratio of active area

Backlight IL=8.5mA

Measurement Condition (Contrast ratio Backlight OFF only)

Measuring instruments: LCD7200(OTSUKA ELECTRONICS),Ring Light(40,000 lx,φ58)

Driving condition: Refer to the section "Optical Characteristics"

Measured temperature: 25° C unless specified

Measurement system: See the chart below.

Measurement point: At the center of the screen.

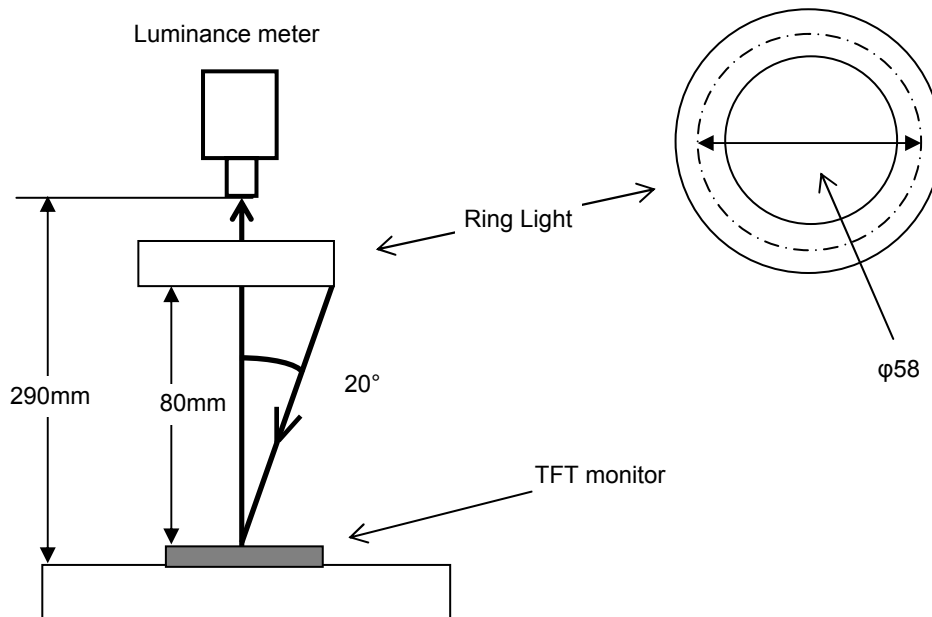

2. Test Method

Notice	Item	Test method	Measuring instrument	Remark
1	Response time	<p>Measure output signal waves with a brightness meter when the raster or window pattern is changed over from white to black and from black to white</p> <p style="text-align: center;">Black White Black</p> <p>White brightness</p> <p>100%</p> <p>90%</p> <p>10%</p> <p>0%</p> <p>Black brightness</p> <p>TON</p> <p>TOFF</p>	LCD7200	<p>Black display [Data]=00h</p> <p>White display [Data]=FFh</p> <p>TON</p> <p>Rise time</p> <p>TOFF</p> <p>Fall time</p>
2	Contrast ratio	<p>Measure maximum luminance Y1([Data]=FFh) and minimum luminance Y2([Data]=00h) at the center of the screen by displaying raster or window pattern. Then calculate the ratio between these two values.</p> <p>Contrast ratio = Y1/Y2</p> <p>Diameter of measuring point: 8mmφ(CS1000)</p> <p>Diameter of measuring point: 3mmφ(LCD7200)</p>	CS1000 LCD7200	Backlight ON Backlight OFF
3	Viewing angle Horizontalθ Verticalφ	Move the luminance meter from right to left and up and down and determine the angles where contrast ratio is 10.	EZcontrast160D	
4	White chromaticity	<p>Measure chromaticity coordinates x and y of CIE1931 colorimetric system at [Data] = FFh</p> <p>Color matching function: 2°view</p>	CS1000	
5	Burn-in	Visually check burn-in image on the screen after 2 hours of "window display" ([Data]=00h/FFh).		At optimized VCOMDC
6	Center brightness	Measure the brightness at the center of the screen.	CS1000	
7	Brightness distribution	<p>(Brightness distribution) = 100 x B/A %</p> <p>A : max. brightness of the 9 points</p> <p>B : min. brightness of the 9 points</p>	CS1000	

Our company network supports you worldwide with offices in Germany, Austria, Switzerland, Great Britain and the USA. For more information please contact:

Headquarters

Germany



FORTEC Elektronik AG

Lechwiesenstr. 9
86899 Landsberg am Lech

Phone: +49 8191 91172-0
E-Mail: sales@forteca.de
Internet: www.forteca.de

Fortec Group Members

Austria



FORTEC Elektronik AG

Office Vienna

Nuschinggasse 12
1230 Wien

Phone: +43 1 8673492-0
E-Mail: office@fortec.at
Internet: www.fortec.at

Germany



Distec GmbH

Augsburger Str. 2b
82110 Germering

Phone: +49 89 894363-0
E-Mail: info@distec.de
Internet: www.distec.de

Switzerland



ALTRAC AG

Bahnhofstraße 3
5436 Würenlos

Phone: +41 44 7446111
E-Mail: info@altrac.ch
Internet: www.altrac.ch

United Kingdom



Display Technology Ltd.

5 The Oaks Business Village
Revenge Road, Lordswood
Chatham, Kent, ME5 8LF

Phone: +44 1634 62755
E-Mail: info@displaytechnology.co.uk
Internet: www.displaytechnology.co.uk

USA



Apollo Display Technologies, Corp.

87 Raynor Avenue,
Unit 1 Ronkonkoma,
NY 11779

Phone: +1 631 5804360
E-Mail: info@apolloDisplays.com
Internet: www.apolloDisplays.com