



OUR GLOBAL
COMPETENCE
CENTRES

 APOLLO DISPLAY
TECHNOLOGIES



 DISTEC



 DISPLAY
TECHNOLOGY



Datasheet

Distec

DD-0500-MG03

DD-01-004

RECORD OF REVISION

Revision Date	Page	Contents	Editor
2021/07/19	--	New Release	CS

1. Features

5 inch Amorphous-TFT-LCD (Thin Film Transistor Liquid Crystal Display) module DD-0500-MG03. This TFT LCD has a 5.0 (5:3) inch diagonally measured active display area with 800x480 (800 horizontal by 480 vertical pixels) resolution. This module is composed of a 5" TFT-LCD panel and backlight unit.

- (1) Construction: a-Si TFT-LCD with driving system, White LED Backlight.
- (2) LCD type : IPS
- (3) Number of the Colors : 16.7M colors (R,G,B 8bit digital each)
- (4) Interface: 24 Bit TTL RGB interfaces. 45 pin.
- (5) LCD Power Supply Voltage: 3.3V single power input, built-in power supply circuit.

2. Physical Specifications

Item	Specifications	unit
Display size (diagonal)	5.0	inch
Resolution	800 (W) x RGB x 480 (H)	dot
Pixel pitch	0.135 (W) x 0.135 (H)	mm
Color configuration	R.G.B Vertical stripe	
Display Mode	Normally Black	

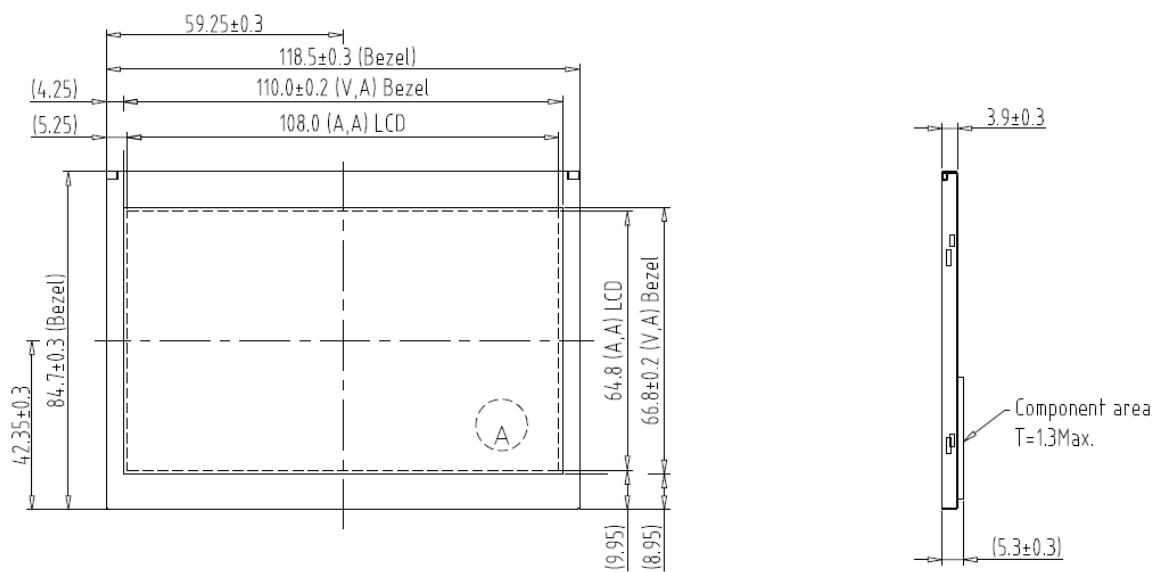

3. Absolute Maximum Ratings

3.1 Electrical Absolute max. ratings

Item	Symbol	Condition	Min.	Max.	Unit	Remark
Power voltage	VCC	GND=0	-0.3	4.0	V	
Logic Input Voltage Range	VIN	GND=0	-0.3	VCC +0.3	V	Note(1)

Note(1) HD, VD, DENA, DCLK, R0~R7, G0~G7, B0~B7.

Note(2) The following are maximum values which, if exceeded, may cause operation or damage to the unit.

3.2 Environmental Absolute Maximum Ratings

Item	Operating		Storage		Remark
	Min.	Max.	Min.	Max.	
Temperature	-30	85	-30	85	Note(2),(3) ,(4),(5),(6),(7)
Humidity	Note(1)		Note(1)		
Corrosive Gas	Not Acceptable		Not Acceptable		

Note(1) Ambient temperature Temp. $\leq 60^{\circ}\text{C}$: 90% RH max

Note(2) For storage condition Ta at $-30^{\circ}\text{C} < 240\text{h}$, at $85^{\circ}\text{C} < 240\text{h}$

Note(3) For operating condition Ta at $-30^{\circ}\text{C} < 100\text{h}$, at $85^{\circ}\text{C} < 240\text{h}$

Note(4) Background color changes slightly depending on ambient temperature. This phenomenon is reversible.

Note(5) The response time will be slower at low temperature.

Note(6) Only operation is guaranteed at operating temperature. Contrast, response time, another display quality are evaluated at $+25^{\circ}\text{C}$

Note(7) When LCM panel is operated over 60°C (center of the panel surface temperature), the IAK of the LED back-light should be adjusted to 10mA(one channel)

Note(8) This is center of the panel surface temperature, not ambient temperature.

Note(9) At 25°C

4. Optical Characteristics

Item		Symbol	Condition	Min.	Typ.	Max.	Unit	Note
Viewing Angle	Hor.	θU	$CR \geq 10$	75	85	--	deg.	(1),(4)
		θD		75	85	--		
	Ver.	θL		75	85	--		
		θR		75	85	--		
Contrast ratio		CR	$\Theta = \Phi = 0^\circ$	800	1000	--	--	(1),(2)
Response Time		$T_R + T_F$	$\Theta = \Phi = 0^\circ$	--	30	40	msec	(1),(3)
Color Gamut		(%)		45	50	--	%	
Color chromaticity	Red	R_x	$\Theta = \Phi = 0^\circ$	Typ. -0.05	TBD	Typ. +0.05	--	(1),(4),(5)
		R_y			TBD			
	Green	G_x			TBD			
		G_y			TBD			
	Blue	B_x			TBD			
		B_y			TBD			
	White	W_x			0.32			
		W_y			0.37			
Luminance (IAK=200mA)		L	$\Theta = \Phi = 0^\circ$	720	900	--	cd/m ²	(1),(6)
Luminance Uniformity		ΔL	$\Theta = \Phi = 0^\circ$	70	-	-	%	(7)

Measuring Condition

Ta=25°C. To be measured on the center area of panel after 10 minutes operation. LED

Back-light IAK=15mA (one channel).

- Measuring surrounding : Dark room
- Ambient temperature : 25±2°C
- 15min. Warm-up time.

Note(1) Definition of Viewing Angle

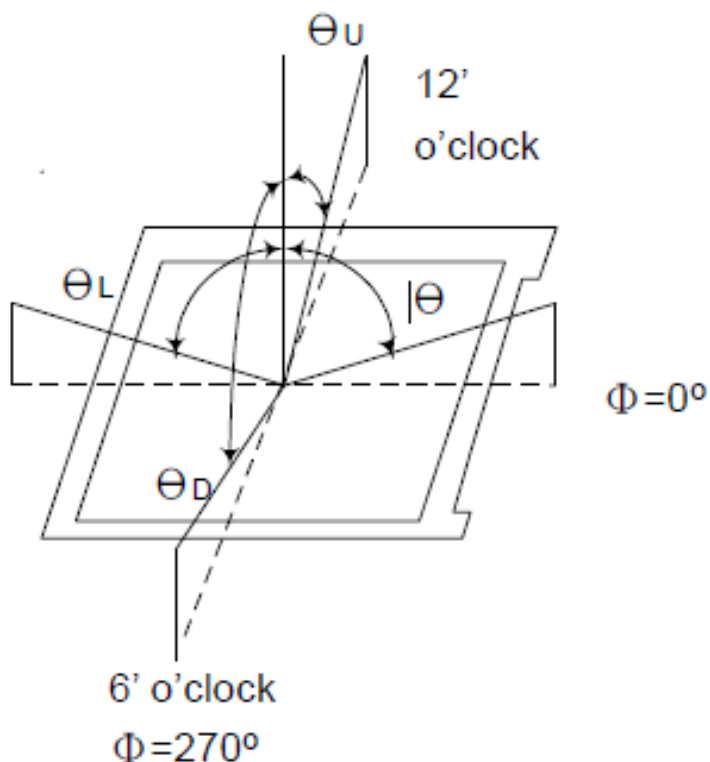

Note(2) Definition of Contrast Ratio (CR) :

Contrast ratio is calculated with the following formula.

$$\text{Contrast ratio (CR)} = \frac{\text{Photo detector output when LCD is at "White" state}}{\text{Photo detector Output when LCD is at "Black" state}}$$

Note(3) Definition of Response Time : Sum of TR and TF

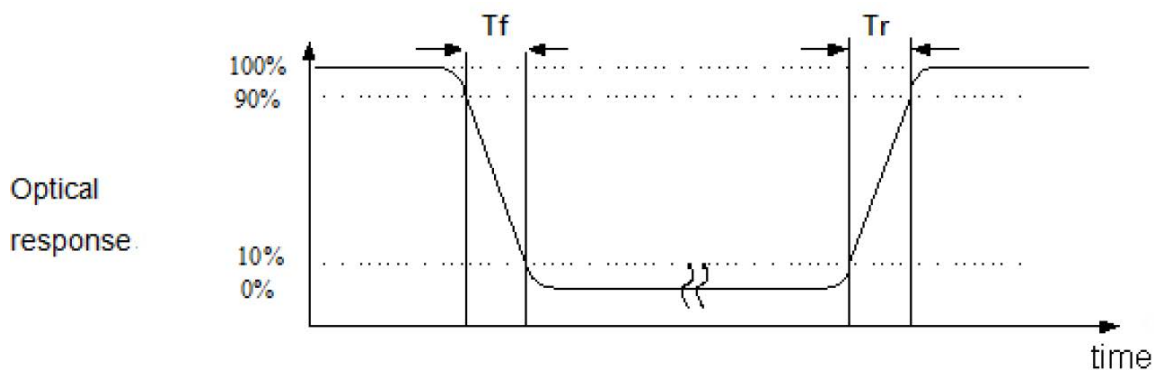

Note(4) Definition of optical measurement setup

The optical characteristics should be measured in dark room. After 30 minutes operation, the optical properties are measured at the center point of the LCD screen. (Response time is measured by Photo detector TOPCON BM-7, other items are measured by BM-5A/Field of view: 1° / Height: 500mm.)

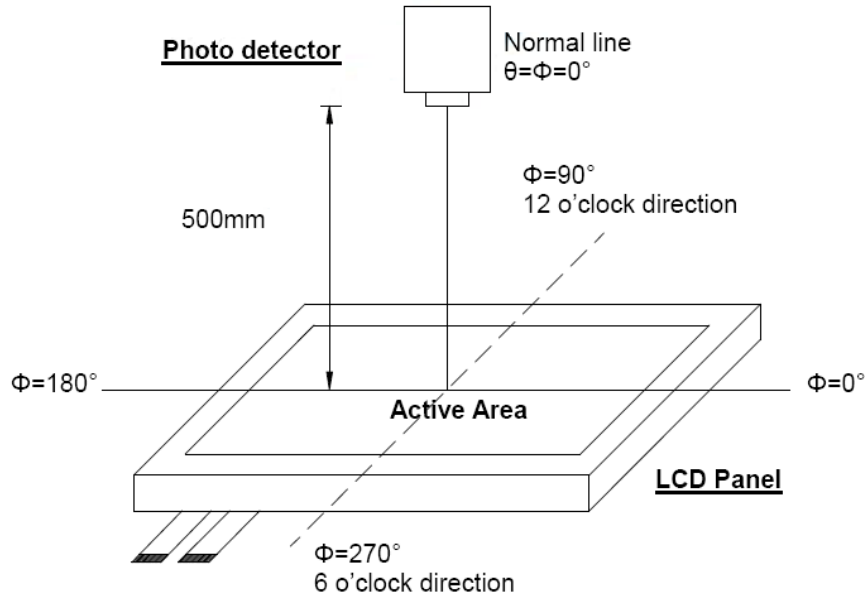

Note(5) Definition of color chromaticity (CIE1931)

Color coordinated measured at center point of LCD.

All input terminals LCD panel must be ground when measuring the center area of the panel.

Note(6) Luminance is measured at point 5 of the display.

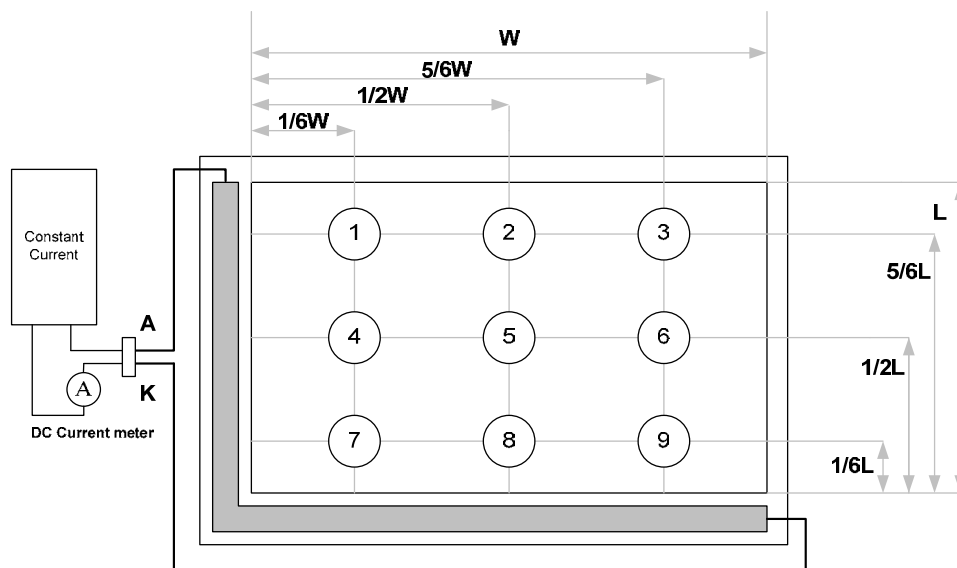

Note(7) Definition of Luminance Uniformity

Active area is divided into 9 measuring areas (Refer to bellow figure).
 Every measuring point is placed at the center of each measuring area.

$$\text{Luminance Uniformity (Yu)} = \frac{B_{\min}}{B_{\max}}$$

L ----- Active area length W ----- Active area width

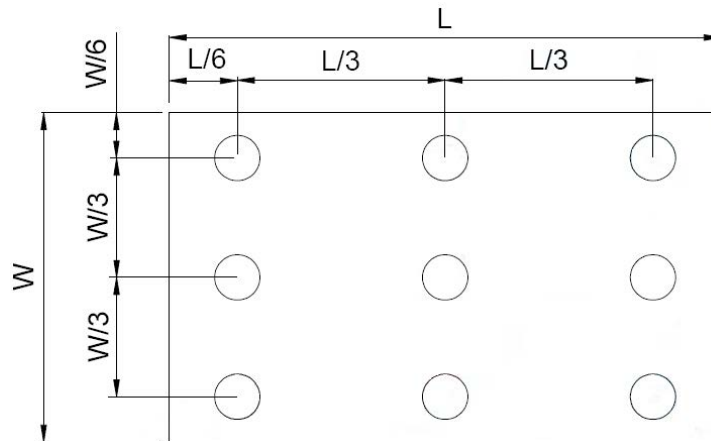

B_{max}: The measured maximum luminance of all measurement position.

B_{min}: The measured minimum luminance of all measurement position.

5. Electrical Characteristics

5.1 DC Characteristics

Item	Symbol	Min.	Typ.	Max.	Unit	Note
Power supply voltage	VCC	3.3	--	3.6	V	
Input voltage for logic	H Level	$0.7 \cdot V_{CC}$	--	VCC	V	(1)
	L Level	GND	--	$0.3 \cdot V_{CC}$	V	
Power Supply current	ICC	--	70	--	mA	(2)

Note(1) HD, VD, DENA, DCLK, and R0~R7, G0~G7, B0~B7, DISP.

Note(2) $f_V = 60\text{Hz}$, $T_a = 25^\circ\text{C}$, Display pattern : All White.

Note(3) *:Will be reference only

5.2 Electrical Characteristic Of LED Backlight

Item	Symbol	Min.	Typ.	Max.	Unit	Note
LED Forward Voltage	VAK	--	24.0	27.6	V	IAK=15mA, Ta=25°C
LED Forward Current	IAK	--	15	20	mA	Ta=25°C (per string)
LED life time			50k	-	Hrs.	IAK=15mA, Ta=25°C

Note(1) Ta means ambient temperature of TFT-LCD module.

Note(2) If the module is driven by high current or at high ambient temperature & humidity condition. The operating life will be reduced.

Note(3) The constant current source is needed for LED back-light driving.

Note(4) Operating life means brightness goes down to 50% minimum brightness. LED life time is estimated data. Ta=25°C

Note(5) The structure of LED B/L shows as below.

(LED :8 string and 1 parallel per channel)

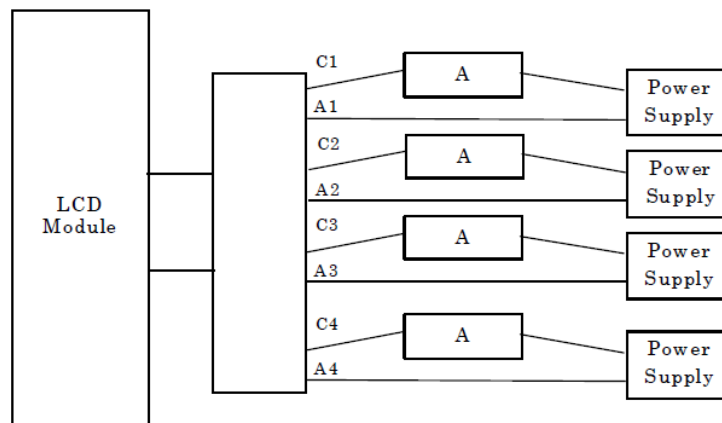

Note(6) When LCM is operated over 60°C ambient temperature, the IAK of the LED backlight should be adjusted to 10mA max

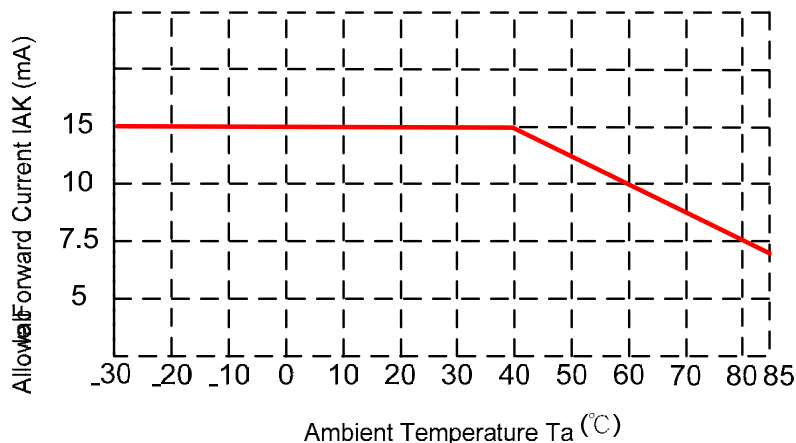

6. Interface Pin Assignment

Pin No	Symbol	Function
1	GND	Power Ground
2	GND	Power Ground
3	VCC	3.3V Power Supply for LCD
4	VCC	3.3V Power Supply for LCD
5	R0	Red Data 0 (LSB)
6	R1	Red Data 1
7	R2	Red Data 2
8	R3	Red Data 3
9	R4	Red Data 4
10	R5	Red Data 5
11	R6	Red Data 6
12	R7	Red Data 7 (MSB)
13	G0	Green Data 0 (LSB)
14	G1	Green Data 1
15	G2	Green Data 2
16	G3	Green Data 3
17	G4	Green Data 4
18	G5	Green Data 5
19	G6	Green Data 6
20	G7	Green Data 7 (MSB)
21	B0	Blue Data 0 (LSB)
22	B1	Blue Data 1
23	B2	Blue Data 2
24	B3	Blue Data 3
25	B4	Blue Data 4
26	B5	Blue Data 5
27	B6	Blue Data 6
28	B7	Blue Data 7(MSB)
29	GND	Power Ground
30	DCLK	Clock Signals
31	DISP	Display on/off (High: on, Low :off)

32	HD	Horizontal SYNC signal.
33	VD	Vertical SYNC signal
34	DENA	Data Enable signal (to settle the viewing area)
35	CMMD	No Connect
36	SC	Scan direction(Low:normal,High:reverse)
37	GND	Power Ground
38	LED_C1	LED cathode1
39	LED_A1	LED anode1
40	LED_C2	LED cathode2
41	LED_A2	LED anode2
42	LED_C3	LED cathode3
43	LED_A3	LED anode3
44	LED_C4	LED cathode4
45	LED_A4	LED anode4

7. Interface Timing

Timing for RGB Interface

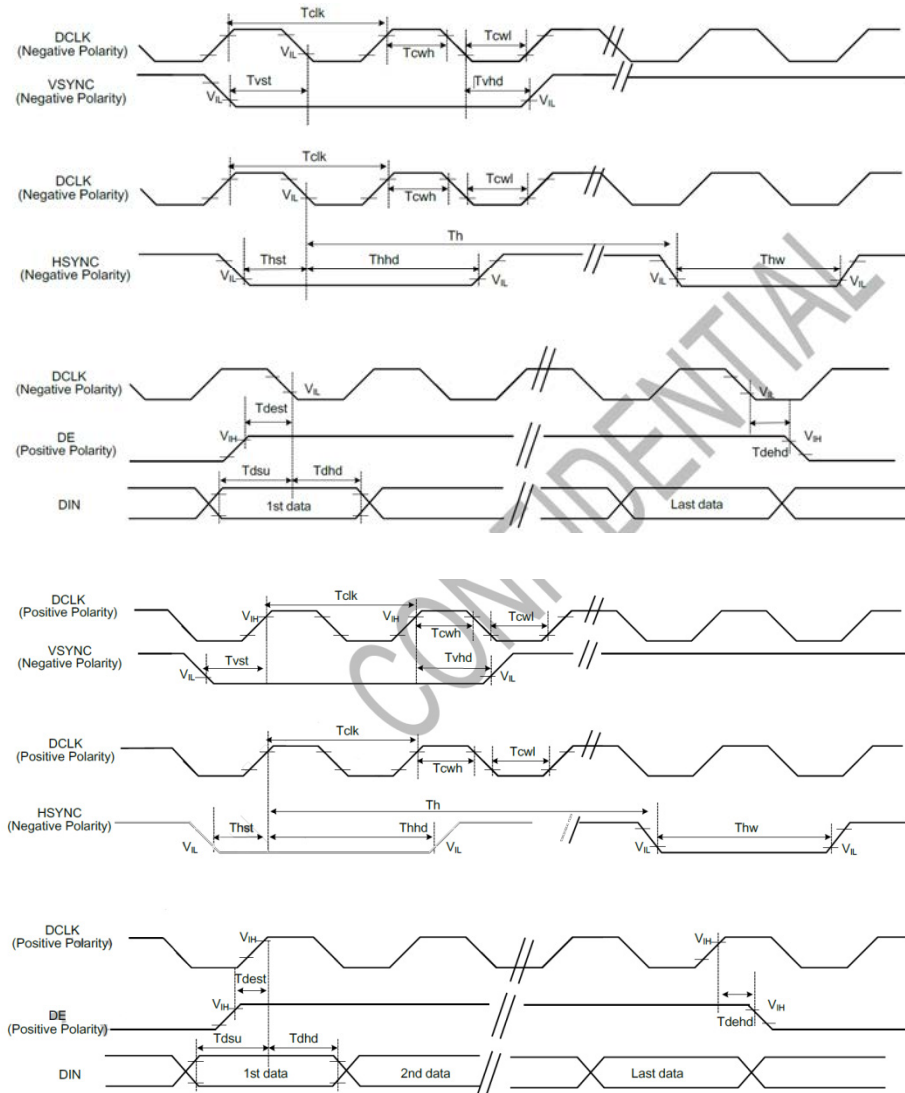

Item	Symbol	Min.	Typ.	Max.	Unit	Conditions
CLK Pulse Duty	T_{cwl}	40	50	60	%	
HSYNC Width	T_{hw}	2	-	-	DCLK	
HSYNC Period	T_h	55	60	65	us	
VSYNC Setup Time	T_{vst}	12	-	-	ns	
VSYNC Hold Time	T_{vhd}	12	-	-	ns	
HSYNC Setup Time	T_{hst}	12	-	-	ns	
HSYNC Hold Time	T_{hhd}	12	-	-	ns	
Data Setup Time	T_{dsu}	12	-	-	ns	
Data Hold Time	T_{dhd}	12	-	-	ns	
DE Setup Time	T_{dst}	12	-	-	ns	
DE Hold Time	T_{dehd}	12	-	-	ns	

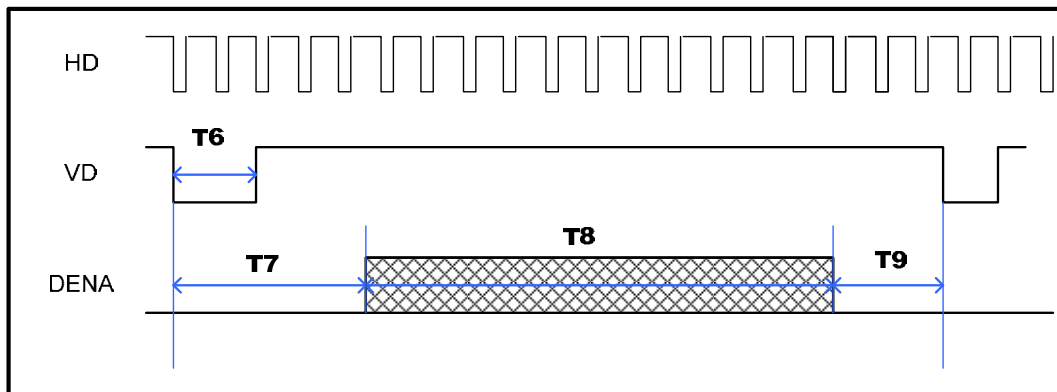
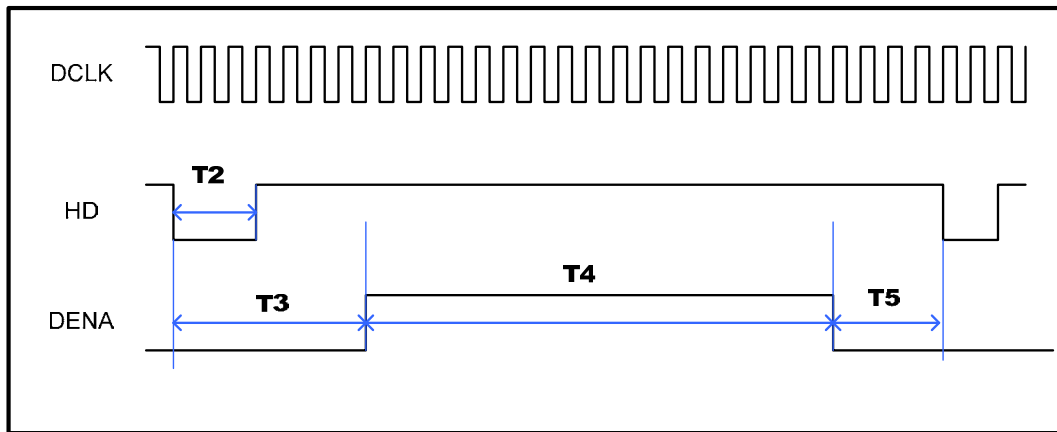
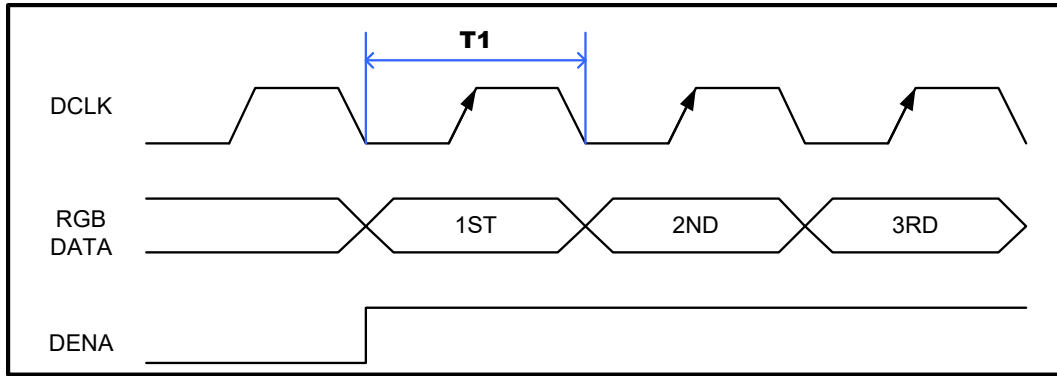

Item	Symbol	Min.	Typ.	Max.	Unit
Clock Frequency	1/T1	23	25	27	MHz
HSYNC Pulse Wide	T2	2	8	8	clocks
HSYNC Back Porch	T3	4	8	48	Clocks
HSYNC Front Porch	T5	4	8	48	Clocks
Horizontal Display Period	T4	800			Clocks
Horizontal total Period	T3+T4+T5	808	816	896	Clocks
VSYNC Pulse Wide	T6	2	4	8	Lines
VSYNC Back Porch	T7	4	8	12	Lines
VSYNC Front Porch	T9	4	8	12	Lines
Vertical Display Period	T8	480			Lines
Vertical total Period	T7+T8+T9	488	496	504	Lines

8. Power On/Off Sequence

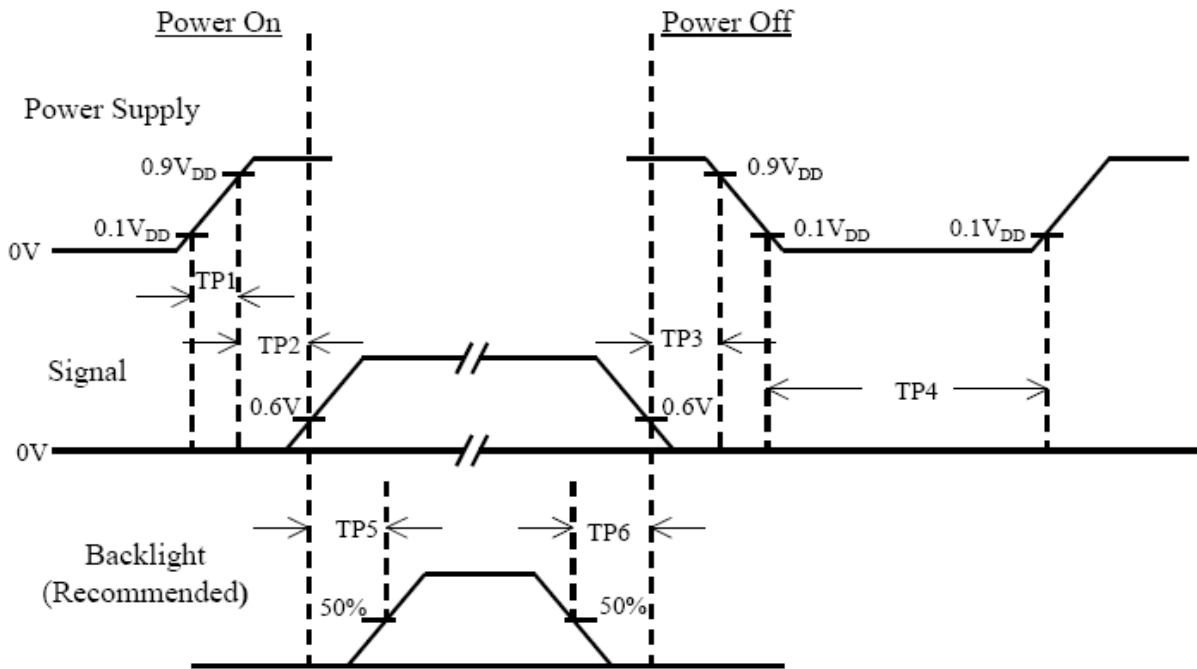

Item	Min.	Typ.	Max.	Unit	Remark
TP1	0.5	--	10	msec	
TP2	0	--	50	msec	
TP3	0	--	50	msec	
TP4	500	--	--	msec	
TP5	200	--	--	msec	
TP6	200	--	--	msec	

Note(1) The supply voltage of the external system for the module input should be the same as the definition of VCC.

Note(2) Apply the lamp voltage within the LCD operation range. When the back-light turns on before the LCD operation or the LCD turns off before the back-light turns off, the display may momentarily become white.

Note(3) In case of VCC = off level, please keep the level of input signal on the low or keep a high impedance.

Note(4) TP4 should be measured after the module has been fully discharged between power off and on period.

Note(5) Interface signal shall not be kept at high impedance when the power is on.

9. Displayed Color and Input Data

Data Signal

COLOR		INPUT DATA																													
		R DATA								G DATA								B DATA													
		R7	R6	R5	R4	R3	R2	R1	R0	G7	G6	G5	G4	G3	G2	G1	G0	B7	B6	B5	B4	B3	B2	B1	B0						
		MSB								LSB								MSB								LSB					
BASIC COLOR	BLACK	0	0	0	0	0	0	0	0	0	0	0	0	0	0	0	0	0	0	0	0	0	0	0	0						
	RED(255)	1	1	1	1	1	1	1	1	0	0	0	0	0	0	0	0	0	0	0	0	0	0	0	0						
	GREEN(255)	0	0	0	0	0	0	0	0	1	1	1	1	1	1	1	1	0	0	0	0	0	0	0	0						
	BLUE(255)	0	0	0	0	0	0	0	0	0	0	0	0	0	0	0	0	1	1	1	1	1	1	1	1						
	CYAN	0	0	0	0	0	0	0	0	1	1	1	1	1	1	1	1	1	1	1	1	1	1	1	1						
	MAGENTA	1	1	1	1	1	1	1	1	0	0	0	0	0	0	0	0	1	1	1	1	1	1	1	1						
	YELLOW	1	1	1	1	1	1	1	1	1	1	1	1	1	1	1	1	0	0	0	0	0	0	0	0						
	WHITE	1	1	1	1	1	1	1	1	1	1	1	1	1	1	1	1	1	1	1	1	1	1	1	1						
RED	RED(1)	0	0	0	0	0	0	0	1	0	0	0	0	0	0	0	0	0	0	0	0	0	0	0	0						
	RED(2)	0	0	0	0	0	0	1	0	0	0	0	0	0	0	0	0	0	0	0	0	0	0	0	0						
	RED(255)	1	1	1	1	1	1	1	1	0	0	0	0	0	0	0	0	0	0	0	0	0	0	0	0						
GREEN	GREEN(1)	0	0	0	0	0	0	0	0	0	0	0	0	0	0	0	1	0	0	0	0	0	0	0	0						
	GREEN(2)	0	0	0	0	0	0	0	0	0	0	0	0	0	0	1	0	0	0	0	0	0	0	0	0						
	GREEN(255)	0	0	0	0	0	0	0	0	1	1	1	1	1	1	1	1	0	0	0	0	0	0	0	0						
BLUE	BLUE(1)	0	0	0	0	0	0	0	0	0	0	0	0	0	0	0	0	0	0	0	0	0	0	0	1						
	BLUE(2)	0	0	0	0	0	0	0	0	0	0	0	0	0	0	0	0	0	0	0	0	0	0	1	0						
	BLUE(255)	0	0	0	0	0	0	0	0	0	0	0	0	0	0	0	0	1	1	1	1	1	1	1	1						

10. Reliability Test Conditions

Test Item	Test Conditions	Note
High Temperature Operation	85±3°C , t=240 hrs	
Low Temperature Operation	-30±3°C , t=240 hrs	
High Temperature Storage	85±3°C , t=240 hrs	(1),(2)
Low Temperature Storage	-30±3°C , t=240 hrs	(1),(2)
Storage Humidity Test	60 °C, Humidity 90%, 240 hrs	(1),(2)
Vibration Test (Packing)	Sweep frequency : 10 ~ 50 ~ 10 Hz/1min Amplitude : 0.75mm Test direction : X.Y.Z/3 axis Duration : 30min/each axis	(2)

Note(1) Condensation of water is not permitted on the module.

Note(2) The module should be inspired after 1 hour storage in normal conditions (15~35°C, 45~65%RH).

Note(3) The module shouldn't be tested over one condition, and all the tests are independent.

Note(4) All reliability tests should be done without the protective film.

Definitions of life end point:

- Current drain should be smaller than the specific value.
- Function of the module should be maintained.
- Appearance and display quality should not have degraded noticeably.
- Contrast ratio should be greater than 50% of initial value.

11. Use Precautions

11.1 Handling precautions

- (1) The polarizing plate may break easily so be careful when handling it. Do not touch, press or rub it with a hard-material tool like tweezers.
- (2) Do not touch the polarizing plate surface with bare hands so as not to make it dirty. If the surface or other related part of the polarizing plate is dirty, soak a soft cotton cloth or chamois leather in benzine and wipe off with it. Do not use chemical liquids such as acetone, toluene and isopropyl alcohol. Failure to do so may bring chemical reaction phenomena and deteriorations.
- (3) Remove any spit or water immediately. If it is left for hours, the suffered part may deform or decolorize.
- (4) If the LCD element breaks and any LC stuff leaks, do not suck or lick it. Also if LC stuff is stuck on your skin or clothing, wash thoroughly with soap and water immediately.

11.2 Installing precautions

- (1) The PCB has many ICs that may be damaged easily by static electricity. To prevent breaking by static electricity from the human body and clothing, earth the human body properly using the high resistance and discharge static electricity during the operation. In this case, however, the resistance value should be approx. $1M\Omega$ and the resistance should be placed near the human body rather than the ground surface. When the indoor space is dry, static electricity may occur easily so be careful. We recommend the indoor space should be kept with humidity of 60% or more. When a soldering iron or other similar tool is used for assembly, be sure to earth it.
- (2) When installing the module and ICs, do not bend or twist them. Failure to do so may crack LC element and cause circuit failure.
- (3) To protect LC element, especially polarizing plate, use a transparent protective plate (e.g., acrylic plate, glass etc) for the product case.
- (4) Do not use an adhesive like a both-side adhesive tape to make LCD surface (polarizing plate) and product case stick together. Failure to do so may cause the polarizing plate to peel off.

11.3 Storage precautions

- (1) Avoid a high temperature and humidity area. Keep the temperature between 0°C and 35°C and also the humidity under 60%.
- (2) Choose the dark spaces where the product is not exposed to direct sunlight or fluorescent light.
- (3) Store the products as they are put in the boxes provided from us or in the same conditions as we recommend.

11.4 Operating precautions

- (1) Do not boost the applied drive voltage abnormally. Failure to do so may break ICs. When applying power voltage, check the electrical features beforehand and be careful. Always turn off the power to the LC module controller before removing or inserting the LC module input connector. If the input connector is removed or inserted while the power is turned on, the LC module internal circuit may break.
- (2) The display response may be late if the operating temperature is under the normal standard, and the display may be out of order if it is above the normal standard. But this is not a failure; this will be restored if it is within the normal standard.
- (3) The LCD contrast varies depending on the visual angle, ambient temperature, power voltage etc. Obtain the optimum contrast by adjusting the LC drive voltage.
- (4) When carrying out the test, do not take the module out of the low-temperature space suddenly. Failure to do so will cause the module condensing, leading to malfunctions.
- (5) Make certain that each signal noise level is within the standard (L level: 0.2V_{dd} or less and H level: 0.8V_{dd} or more) even if the module has functioned properly. If it is beyond the standard, the module may often malfunction. In addition, always connect the module when making noise level measurements.
- (6) The CMOS ICs are incorporated in the module and the pull-up and pull-down function is not adopted for the input so avoid putting the input signal open while the power is ON.
- (7) The characteristic of the semiconductor element changes when it is exposed to light emissions, therefore ICs on the LCD may malfunction if they receive light emissions. To prevent these malfunctions, design and assemble ICs so that they are shielded from light emissions.
- (8) Crosstalk occurs because of characteristics of the LCD. In general, crosstalk occurs when the regularized display is maintained. Also, crosstalk is affected by the LC drive voltage. Design the contents of the display, considering crosstalk.

11.5 Other

- (1) Do not disassemble or take the LC module into pieces. The LC modules once disassembled or taken into pieces are not the guarantee articles.
- (2) The residual image may exist if the same display pattern is shown for hours. This residual image, however, disappears when another display pattern is shown. Or, the drive is interrupted and left for a while. But this is not a problem on reliability.
- (3) **Do not keep the LCD at the same display pattern continually. The residual image will happen and it will damage the LCD. Please use screen saver.**

12. Outline Dimension

1	GND	24	B3
2	GND	25	B4
3	VCC	26	B5
4	VCC	27	B6
5	R0	28	B7
6	R1	29	GND
7	R2	30	DCLK
8	R3	31	DISP
9	R4	32	HD
10	R5	33	VD
11	R6	34	DENA
12	R7	35	CMMD
13	G0	36	SC
14	G1	37	GND
15	G2	38	LED_C1
16	G3	39	LED_A1
17	G4	40	LED_C2
18	G5	41	LED_A2
19	G6	42	LED_C3
20	G7	43	LED_A3
21	B0	44	LED_C4
22	B1	45	LED_A4
23	B2		

Top View Dimensions:
 Overall width: 110.0 ± 0.2 (V,A) Bezel
 Bezel width: 84.7 ± 0.3 (Bezel)
 LCD width: 64.8 (A,A) LCD
 Bezel width (bottom): 66.8 ± 0.2 (V,A) Bezel
 LCD height: 59.25 ± 0.3
 Bezel height: 118.5 ± 0.3 (Bezel)
 LCD height (inner): 108.0 (A,A) LCD
 Mounting hole offset: 4.25 (top), 5.25 (bottom)
 Bezel offset: 42.35 ± 0.3
 Mounting hole diameter: 3.9 ± 0.3
 Component area thickness: $T = 1.3 \text{Max.}$
 Mounting hole offset (bottom): 5.3 ± 0.3

Side View Dimensions:
 Mounting hole diameter: 3.9 ± 0.3
 Mounting hole offset (bottom): 5.3 ± 0.3

Detail A Block:
 Hole diameter: 0.135
 Hole offset: 0.045

Note:
 1. Unless indicated, Tolerance $\pm 0.3^*$
 2. UV Glue For OLB Protection.
 3. LCD 800x480 (R.G.B) TFT LCD => 5.0" TFT LCD

REV.	REVISION RECORD	DATE	NAME
0	NEW RELEASE	07-16-21	SNOW

TITLE	DWG. NO.	SHEET	OF
DD-0500-MG03 (5.0") IPS	*2107102MA	1	1

A FORTEC GROUP MEMBER

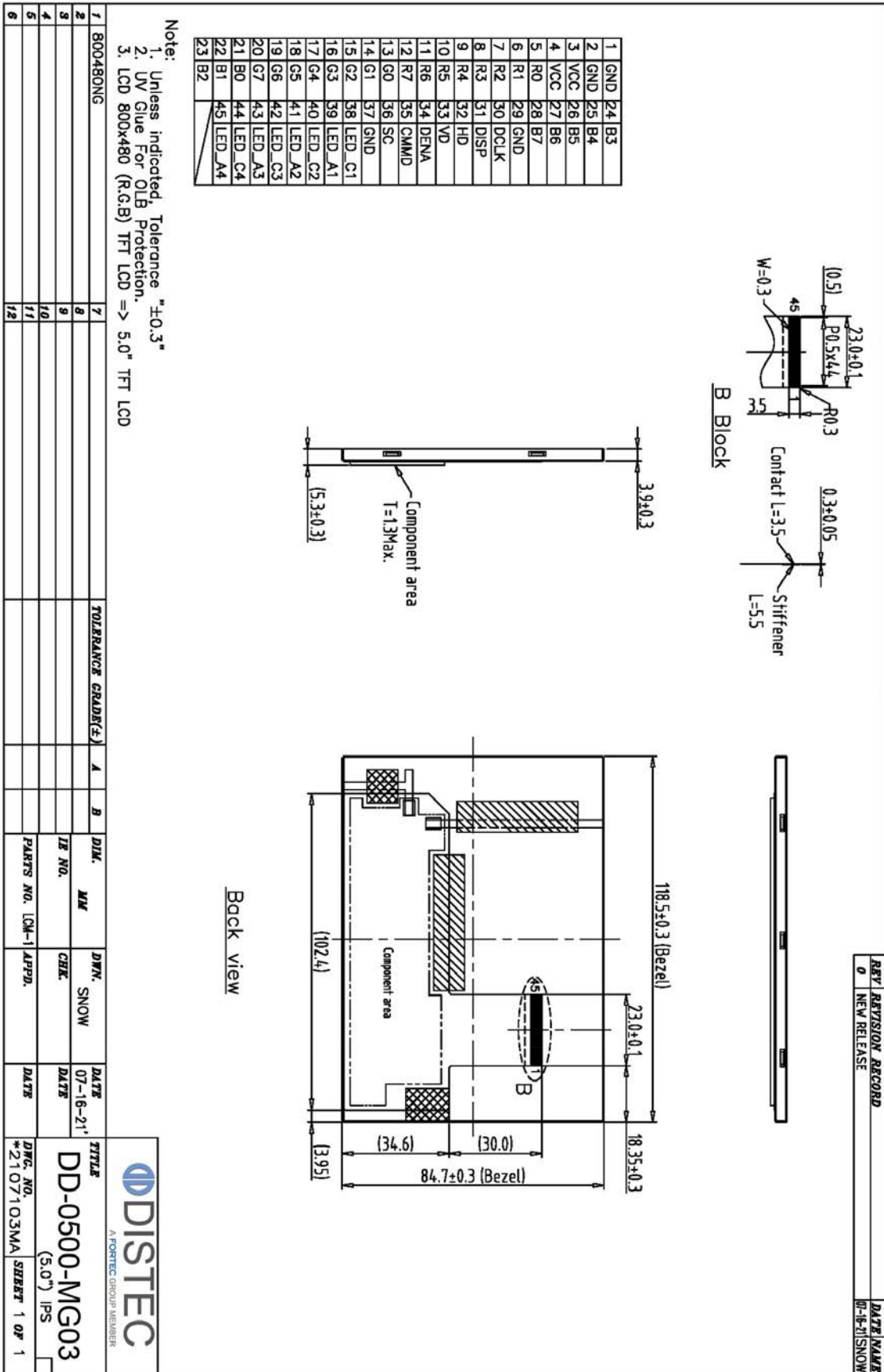

REV	REVISION RECORD	DATE	NAME
0	NEW RELEASE	07-16-21	SNOW

DISTEC
 A FORTEC GROUP MEMBER

DD-0500-MG03
 (5.0") IPS

DMG. NO. *21.07103MA SHEET 1 OF 1

13. Package

TBD

Our company network supports you worldwide with offices in Germany, Austria, Switzerland, the UK and the USA. For more information please contact:

Headquarters

Germany



FORTEC Elektronik AG

Augsburger Str. 2b
82110 Germering

Phone: +49 89 894450-0
E-Mail: info@forteca.de
Internet: www.forteca.de

Fortec Group Members

Austria



Distec GmbH Office Vienna

Nuschinggasse 12
1230 Wien

Phone: +43 1 8673492-0
E-Mail: info@distec.de
Internet: www.distec.de

Germany



Distec GmbH

Augsburger Str. 2b
82110 Germering

Phone: +49 89 894363-0
E-Mail: info@distec.de
Internet: www.distec.de

Switzerland



ALTRAC AG

Bahnhofstraße 3
5436 Würenlos

Phone: +41 44 7446111
E-Mail: info@altrac.ch
Internet: www.altrac.ch

United Kingdom



Display Technology Ltd.

Osprey House, 1 Osprey Court
Hichingbrooke Business Park
Huntingdon, Cambridgeshire, PE29 6FN

Phone: +44 1480 411600
E-Mail: info@displaytechnology.co.uk
Internet: www.displaytechnology.co.uk

USA



Apollo Display Technologies, Corp.

87 Raynor Avenue,
Unit 1 Ronkonkoma,
NY 11779

Phone: +1 631 5804360
E-Mail: info@apolloDisplays.com
Internet: www.apolloDisplays.com